

EN

Instructions for Fitting, Operating and Maintenance

Canopy Door

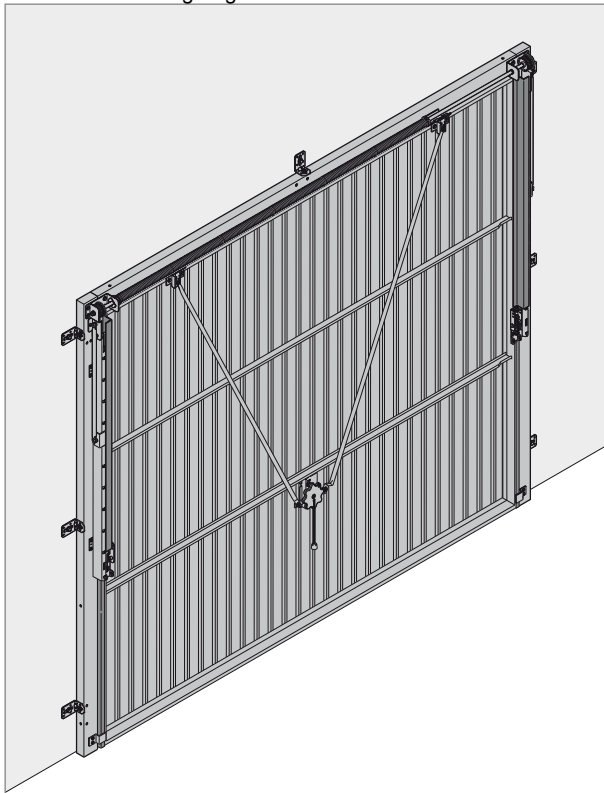

Contents

1	⚠ Safety Instructions	3	4.9	Accessories	10
1.1	Qualified persons.....	3	5	Surface Protection.....	10
1.2	Symbols and signal words used.....	3	5.1	Door with steel infill	10
1.3	Intended use.....	4	5.2	Door with timber or GRP infill	11
1.4	General safety instructions.....	4	6	Cleaning and Care	11
2	Fitting and Initial Start-Up.....	5	6.1	Door surfaces made of steel	11
2.1	Safety instructions.....	5	6.2	Synthetic panes.....	11
2.2	Fitting.....	5	6.3	Data plate	11
2.2.1	Doors with centre profile/horizontal ribbing.....	6	7	Assistance with Malfunctions.....	11
2.2.2	Fitting the handle.....	6	8	Dismantling	12
2.3	Initial start-up.....	7		Illustrations steel frame	13
2.3.1	Checking the spring tension.....	7		Illustrations timber frame	29
3	Operation.....	8			
3.1	Safety instructions.....	8			
3.2	Opening the door with the handle	8			
3.3	Locking and unlocking the door.....	8			
4	Inspection and Maintenance	9			
4.1	Safety instructions.....	9			
4.2	Checking the condition of the door	9			
4.3	Inspect all load-bearing components.....	9			
4.4	Anti-fall safeguard.....	10			
4.5	Checking the door spring	10			
4.6	Replacing the door torsion spring	10			
4.7	Checking the track rollers and tracks.....	10			
4.8	Checking the lock and locking mechanism.....	10			



Illustrations steel frame **13**

Illustrations timber frame **29**

Make sure that these instructions remain with the door operator!

Read and follow these instructions carefully!

They provide you with important information on safe fitting and operation, as well as proper care and maintenance of your garage door.

Keep these instructions and the warranty booklet with the declaration of conformity in a safe place.

Enter the serial number (see the data plate) here.

Serial no.:

1 Safety Instructions

The manufacturer is not liable for damage resulting from non-compliance with these instructions and the safety instructions.

1.1 Qualified persons

Have a qualified person (competent persons in acc. with EN 12635) fit, start-up and maintain the door following these instructions. While doing so, the requirements listed in the standards EN 12604 and EN 12635 must be observed.

1.2 Symbols and signal words used

Special safety information is provided at respective important points in these instructions. They are identified by the following symbols and signal words.



The general warning symbol indicates a danger that can lead to **injury** or **death**.



WARNING

Indicates a danger that can lead to death or serious injuries.



CAUTION

Indicates a danger that can lead to minor or moderate injuries.

ATTENTION

Indicates a danger that can lead to **damage** or **destruction** of the product.



Important note for avoiding damage to property



Permissible arrangement or activity



Non-permissible arrangement or activity

ENGLISH

See the text section (e.g. Section 2.3.1)



Inspect



Move component slowly



Dispose of components/packaging

1.3 Intended use

- The garage door is only intended for private use. If you would like to use the door in a commercial application, first check whether the currently valid national and international regulations permit such use.
- The garage door is suitable for use outside; it opens outwards with an up-and-over action.
- The garage door can be manually operated or fitted with an operator.

1.4 General safety instructions

- Always keep the swivelling and opening area of the door clear. When in operation, make sure that neither persons, children in particular, nor objects are located within the door's area of travel.
- Do not attach any additional components of another make! The torsion spring is precisely matched to the door leaf weight. Additional components can overload the springs.
- Do not alter or remove any components! You could otherwise risk putting important safety components out of action. Only use original parts intended for use with this particular garage door.
- Protect the door from caustic, aggressive substances, e.g. nitrous reactions from stones or mortar, acids, alkali solutions, de-icing salt, aggressive paints or sealants.
- Make sure that there is sufficient water run-off and ventilation (drying) in the lower section of the side frames.
- Operation of the door during heavy winds may be dangerous.

2 Fitting and Initial Start-Up

2.1 Safety instructions

WARNING

Danger of injury

There is a danger of injury during fitting. Observe the following instructions:



- ▶ Wear safety glasses and protective gloves.



- ▶ Secure the door from falling.
- ▶ Secure the door leaf from crashing to the floor.
- ▶ Fit all delivered fastenings according to the fitting instructions.

ATTENTION

Damage to the product

Observe the following instructions:

- ▶ Make sure that the connection to the building structure is sound. Check that the fixing materials supplied are suitable for the given structural conditions. Do not fasten the door system to supporting structural members unless you have obtained the prior approval of the structural engineer.

- ▶ Throughout fitting, protect the door's components from dirt and damage.
- ▶ Install a door with timber infill only in dry garages.

2.2 Fitting

Fitting to steel frame

The garage door can be fitted from the inside behind the opening or in the opening (see Figure I).

Fitting to timber frame

Before fitting the door, check carefully the opening size and squareness of the timber frame (the door is manufactured slightly smaller to give the correct clearance between door leaf and timber frame). The timber frame should be of the „Goalpost“ type, with a minimum nominal size of 70 mm x 70 mm (2 2/3" x 2 2/3") once erected it should provide an inside frame dimension as detailed.

Door size	Inside frame dimension in Imperial	Inside frame dimension in Metric
6'6" x 6'6"	6'6" x 6'6"	1981 x 1981
6'6" x 7'0"	6'6" x 7'0"	1981 x 2134
6'10" x 6'4"	6'10" x 6'4"	2083 x 1931
7'0" x 6'4"	7'0" x 6'4"	2134 x 1931
7'0" x 6'6"	7'0" x 6'6"	2134 x 1981
7'0" x 7'0"	7'0" x 7'0"	2134 x 2134
7'3" x 6'4"	7'3" x 6'4"	2210 x 1931

Door size	Inside frame dimension in Imperial	Inside frame dimension in Metric
7'5" x 6'6"	7'5" x 6'6"	2261 x 1981
7'5" x 7'0"	7'5" x 7'0"	2261 x 2134
7'6" x 6'4"	7'6" x 6'4"	2286 x 1931
7'6" x 6'6"	7'6" x 6'6"	2286 x 1981
7'6" x 7'0"	7'6" x 7'0"	2286 x 2134
7'8" x 6'4"	7'8" x 6'4"	2337 x 1931
8'0" x 6'4"	8'0" x 6'4"	2438 x 1931
8'0" x 6'6"	8'0" x 6'6"	2438 x 1981
8'0" x 7'0"	8'0" x 7'0"	2438 x 2134
9'0" x 6'6"	9'0" x 6'6"	2743 x 1981
9'0" x 7'0"	9'0" x 7'0"	2743 x 2134

All the dimensions stated in the illustrated section are in mm.

Door for on-site infill

CAUTION

Transport locking device / max. infill weight

Observe the following instructions to avoid any injuries:

- First install the infill and then remove the transport locking device so that the door does not bounce up.

Maximum permissible infill weight for on-site infill: **6-9 kg/m²**

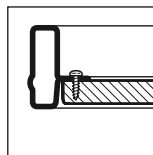

Infill in the frame

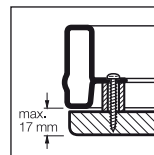

Infill overlapping the frame

2.2.1 Doors with centre profile/horizontal ribbing

The spacer bush with a square hole is only used in doors with centre profile or horizontal ribbing.

2.2.2 Fitting the handle

- Always choose the pin setting (a, b or c) with the largest possible guidance for the interior handle.
- Shorten the pin of part Ⓞ if dimension **A** is less than 36 mm.

To ensure simple and safe fitting, carefully go through the work steps illustrated in Figures 1 to 4.6 (Figures 5 to 8.6)!

2.3 Initial start-up

2.3.1 Checking the spring tension

(Figures 4.5/8.5)

► Open the door.

If the spring is properly tensioned, the garage door can be easily moved, is functionally safe and easy to operate.

Oil all pivot points before retensioning the spring.
This may do away with the need for retensioning.

If the door moves substantially downwards:

► Increase the spring tension.

If the door moves substantially upwards:

► Decrease the spring tension.

⚠ WARNING

Danger of injury due to high torques

The spring is under high torque stress and may discharge high forces if it is not secured during tensioning. Improper adjustment may result in injuries.

- Close the door and fix the door leaf to prevent movement before tensioning the spring.
- Only have a specialist adjust the spring tension in accordance with Figures 4.6/8.6 when the door is secured.

Proceed as follows to retension the spring
(Figures 4.6/8.6):

1. Tighten both grub screws in the spring collar on the left side of the torsion spring using an Allen key (3 mm).
2. To maintain the spring tension, insert a tensioning bar in a locating hole in the tensioning collar on the right side of the torsion spring and then loosen both grub screws in the right tensioning collar.

ATTENTION

Tensioning bar in tensioning collar

Loss of spring tension

- It is important that at least one tensioning bar is always inserted in the tensioning collar and that the spring tension is maintained at all times if one or more grub screws are loosened. If this is not done, there will be a loss of spring tension, which could lead to injuries or damage to the product.

3. Always use 2 tensioning bars to increase or decrease the spring tension.
4. Retighten both grub screws in the right tensioning collar.
5. Loosen the grub screws in the left tensioning collar.
6. Inspect the door travel and check whether the cable is correctly guided in the cable drum groove. If further adjustments are necessary, the spring tension must be reset until the door is properly balanced.

Perform a test run and check the door in accordance with Chapter 4, *Inspection and Maintenance*.

ENGLISH

When properly fitted and inspected, the garage door can be easily moved, is functionally safe and easy to operate.

3 Operation

3.1 Safety instructions

WARNING

Door travel

There is a risk of injury in the door's swivelling and opening area.

- ▶ When in operation, make sure that neither persons, children in particular, nor objects are located within the door's area of travel.
- ▶ Keep a safe distance of 900 mm away from the door.

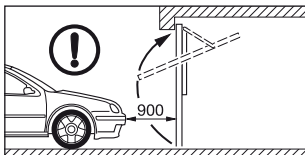

Opening and closing

There is a risk of injury when opening or closing the door improperly.

Manually opening:

- ▶ Only open the door with the exterior handle or interior handle, never with the lever arm or the cord knob.
- ▶ Always slide the door fully into the end-of-travel position and wait until the door has come to a stop.

Manually closing:

- ▶ Only close the door with the exterior handle, interior handle or the cord knob, never with the lever arm.
- ▶ Make sure that the locking engages correctly.

3.2 Opening the door with the handle

The door is not locked when closed with the grip handle. Use the key or locking pin to lock the door.

Opening from the outside:

- ▶ Turn the handle a quarter turn clockwise.

Opening from the inside:

- ▶ Turn the handle a quarter turn anti-clockwise.

3.3 Locking and unlocking the door

From outside with the key and from inside with the locking pin.

Unlocking from the outside:

- ▶ Turn the key one whole turn clockwise and remove the key.

Locking from the outside:

- ▶ Turn the key one whole turn anti-clockwise and remove the key.

Unlocking from the outside - self-locking:

1. Turn the key half a turn clockwise and slightly open the door.
2. Turn the key back to the original position and remove it.

When the door is closed, the lock is locked again.

Unlocking from inside:

- ▶ Push the locking pin to the left.

By unlocking in this way, you can then open the door without a key.

Locking from inside:

- ▶ Push the locking pin to the right.

NOTE:

- Follow the operator manufacturer's instructions for doors with operator.

4 Inspection and Maintenance**4.1 Safety instructions**

- ▶ Have a specialist perform inspection and maintenance work on the door at least once a year in accordance with these instructions.

 **WARNING**
Door travel

There is a risk of injury in the door's swivelling and opening area.

- ▶ When in operation, make sure that neither persons, children in particular, nor objects are located within the door's area of travel.
- ▶ Functional parts, particularly safety components, may only be exchanged by a specialist.

4.2 Checking the condition of the door

- ▶ Visually inspect the general condition of the door, all components, and safety devices for completeness, proper condition, and effectiveness.
- ▶ Check that all of the fixing points are tight. Tighten the screws if necessary.
- ▶ Lubricate all pivot points with a standard penetrating or lube oil. Do not use grease (see Figure 4.1-4.2/8.1-8.2).

4.3 Inspect all load-bearing components
 **WARNING**
Danger of injury due to high cable tension and high torques

Cables and springs are under high tension and torques. Damaged cables or springs may also cause serious injuries.

- ▶ Fix the door leaf to prevent uncontrolled movement before exchanging damaged cables or springs.
- ▶ Special care is required when exchanging damaged cables or springs.

ENGLISH

- ▶ Check the load carriers (cable drums, cables, spring, tracks) for breakage, damage and wear. Have a specialist replace any damaged or worn-out components.

4.4 Anti-fall safeguard

- ▶ The springs of the anti-fall safeguard together with the wire cable should be checked at regular intervals. In the event of a spring breaking the spring (or the entire roller holder) must be replaced by a specialist.

4.5 Checking the door spring

See Chapter 2, *Fitting and Initial Start-Up*.

4.6 Replacing the door torsion spring

- ▶ Have the door torsion spring replaced by a specialist after approx. 25,000 door cycles.

This is required at the following approximate time:

Door cycles per day	Period
Up to 5	Every 15 years
6 – 10	Every 8 years
11 – 20	Every 4 years
21 – 40	Every 2 years
Over 40	yearly

4.7 Checking the track rollers and tracks

- ▶ Clean the tracks. Do not apply grease.
- ▶ Check the track rollers for wear. Have the track rollers replaced by a specialist if they are greatly worn or damaged.

4.8 Checking the lock and locking mechanism**ATTENTION****Care products**

Unsuitable care products may cause damage.

- ▶ Only use specialised care products for the profile cylinder. Do not use oil or graphite.

- ▶ Check the locking as shown in Figures 1.2 (6.2) and adjust it if necessary.

4.9 Accessories

- To ensure a high level of quality, safety, reliability, as well as a long service life, only use original parts intended for this particular garage door.
- Only use an operator approved for the garage door according to EN 13241-1. Follow the separate instructions for fitting and operation provided by the operator manufacturer. Immobilise both lockings.

5 Surface Protection**5.1 Door with steel infill**

The door leaf is made of galvanized material and has been finished with a polyester powder coating. Scratches or minor damage are no reason for complaints. If further painting is required, follow the instructions below:

1. Lightly sand the door surface with a fine sand paper (at least 180 grain size).
2. Clean the door surface with water and then dry it.

3. Apply a 2K-EPOXY-etch primer to the door surface and paint it with a conventional synthetic resin paint for outdoor applications. Coordinate both coatings with each other. When doing so, follow the instructions provided by the paint manufacturer.

Renew the final coat when necessary, depending on the local weather conditions.

5.2 Door with timber or GRP infill

See separate instruction label on inside face of door panel.

6 Cleaning and Care

6.1 Door surfaces made of steel

- ▶ Clean the door surfaces with clear water and a soft sponge or with conventional paint cleaners.

6.2 Synthetic panes

ATTENTION

Cleaning products

Unsuitable cleaning products can cause stress cracks and damage the panes.

- ▶ Do not use any abrasive cleaners, sharp tools or alcohol-based glass cleaners.
- ▶ Clean the synthetic panes with clear water and a soft sponge or cloth.

- ▶ Use a mild, acrylic-compatible plastics cleaner if more heavily soiled. Follow the instructions for use provided by the manufacturer.

6.3 Data plate

- ▶ Clean the data plate.
It must always be easy to read.

7 Assistance with Malfunctions

If the door is difficult to move or exhibits other malfunctions:

- ▶ Check all the functional parts. To do this, please follow the instructions in Chapter 4, *Inspection and Maintenance*.
- ▶ In the case of uncertainty, contact a specialist for assistance.

WARNING

Danger of injury due to uncontrolled door movement

If the door malfunctions, uncontrolled door movements may trap persons or objects.

- ▶ In the event of a door failure (sluggish operation or other malfunctions), a specialist must be commissioned immediately for the inspection/repair work.

Anti-fall safeguard

Once the anti-fall safeguard has been activated, the door leaf weight is no longer balanced. Further operation of the door is no longer possible. Commission a specialist for repairs.

8 Dismantling

Have the door dismantled and disposed of by a specialist.

Dissemination as well as duplication of this document and the use and communication of its content are prohibited unless explicitly permitted. Noncompliance will result in damage compensation obligations. All rights reserved in the event of patent, utility model or design model registration. Subject to changes.

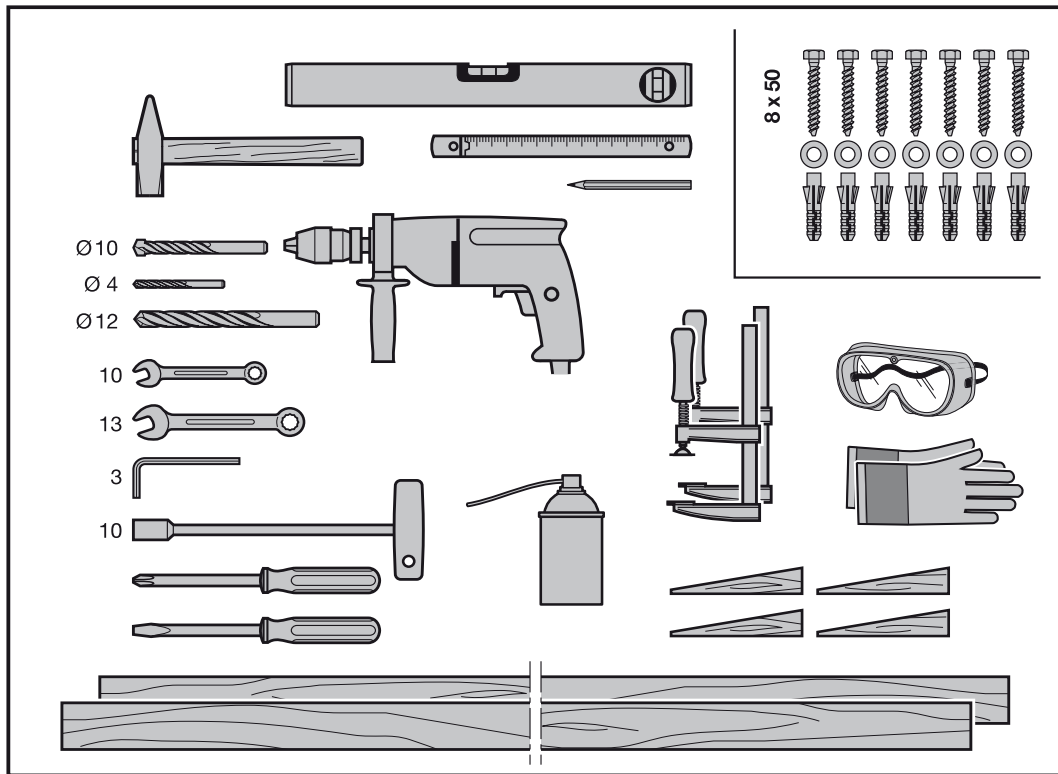

I

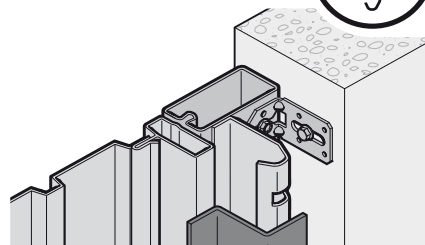
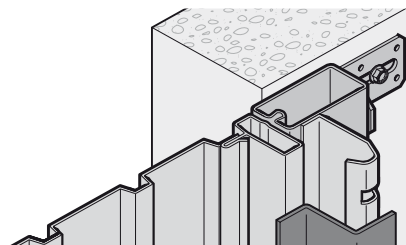
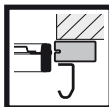

II

III

1

2a

2b

3

4



IV

V

5

6

7

8

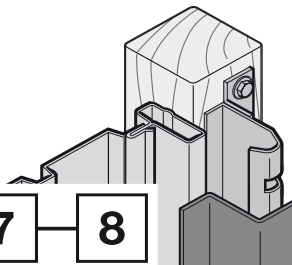

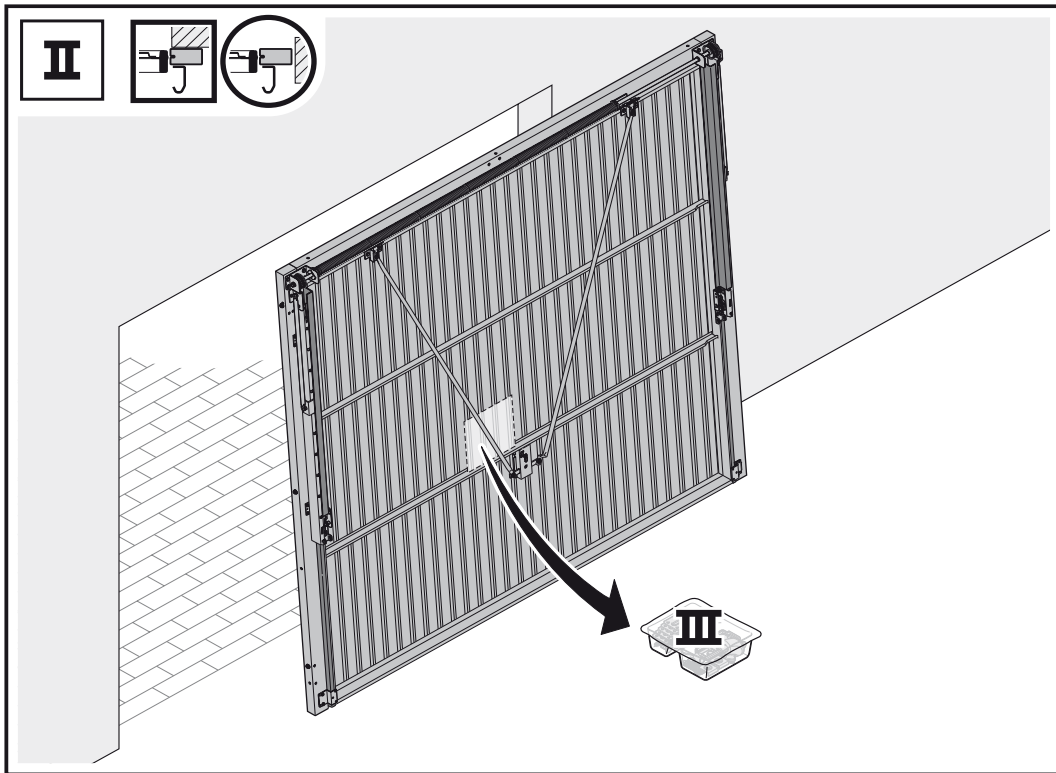

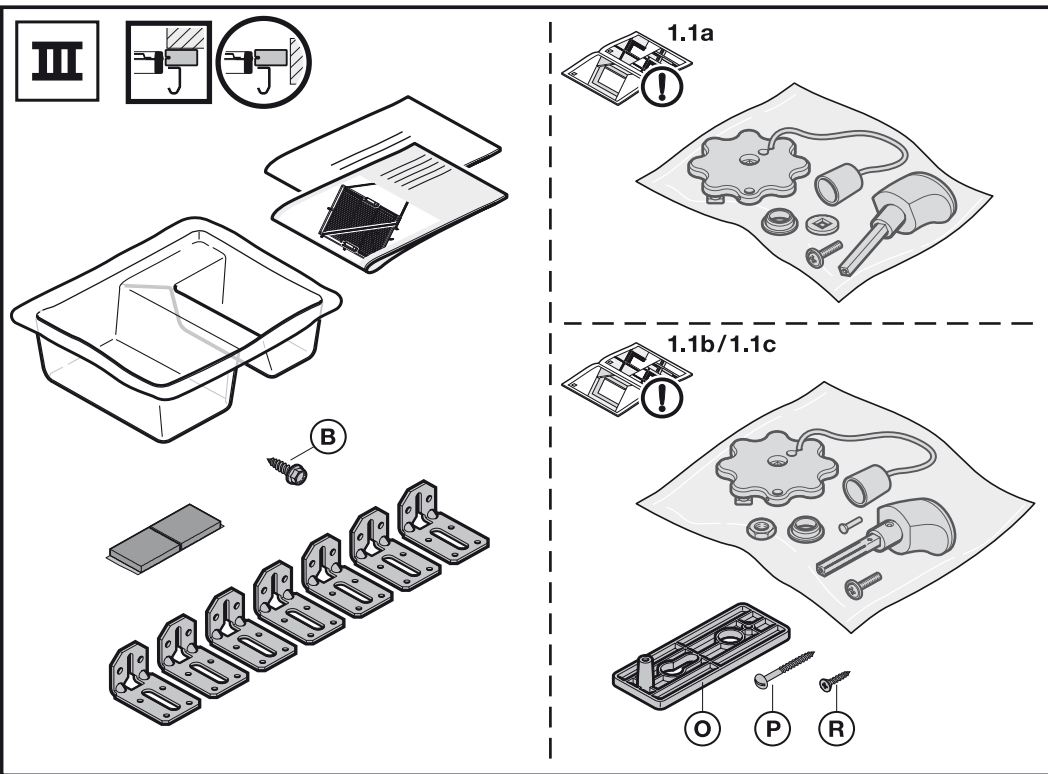

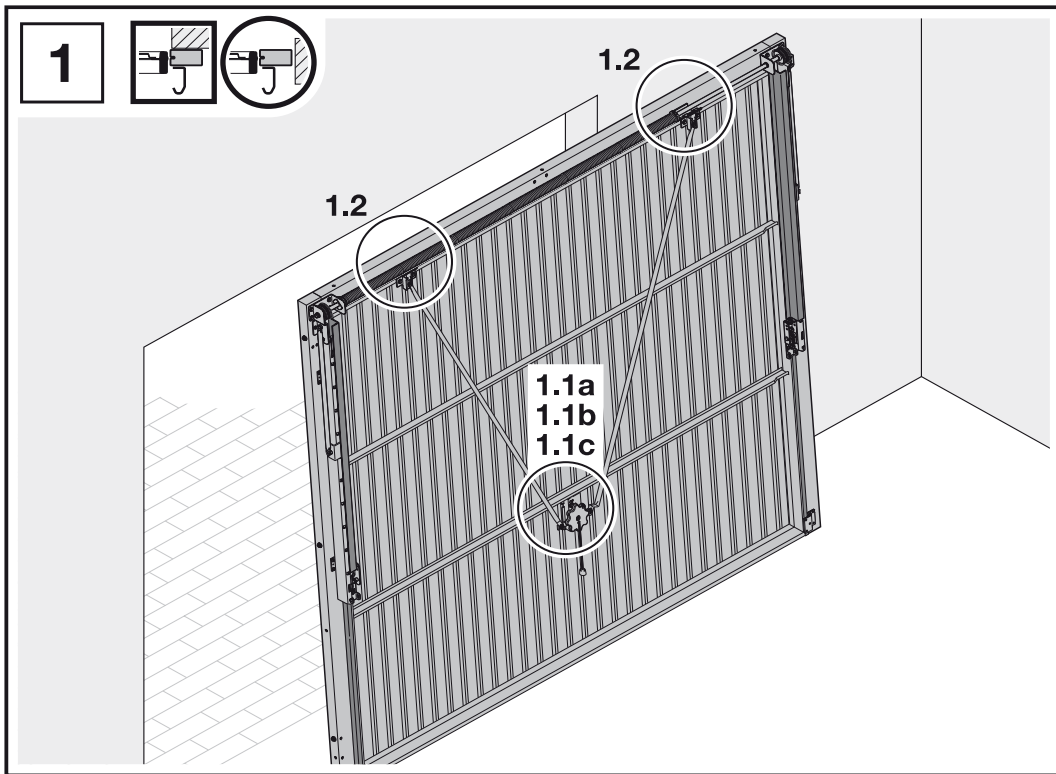

1.1a

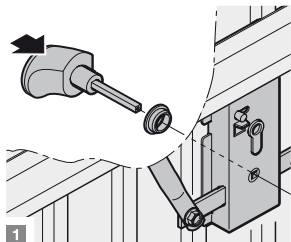
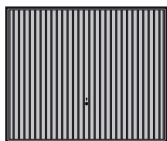

2.2.1

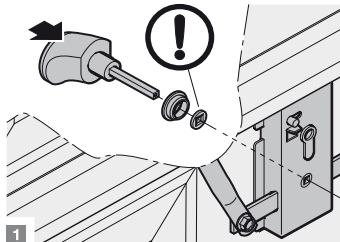
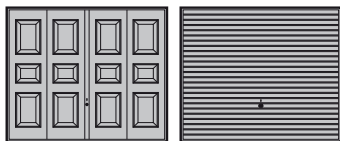

1.1b

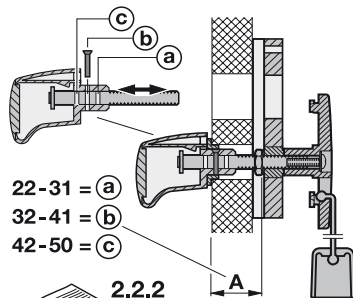

22-31 = a

32-41 = b

42-50 = c

2.2.2

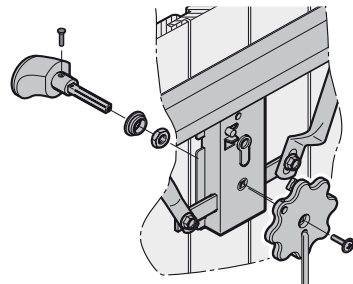
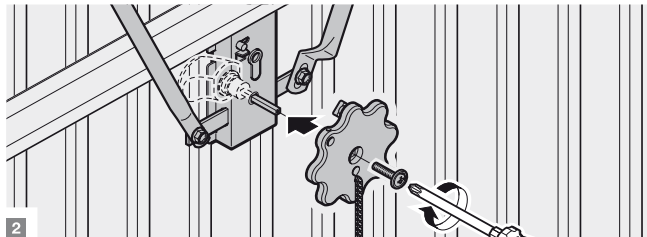

1.1c



2.2.2

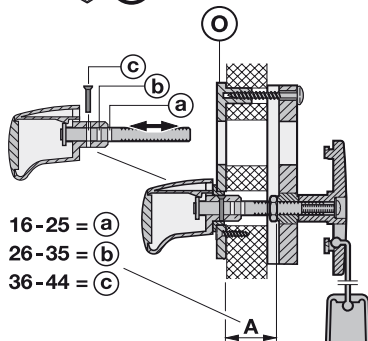
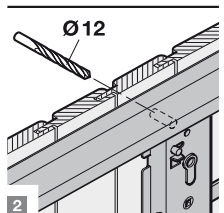
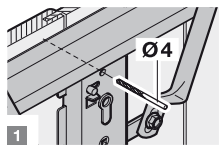

1.2

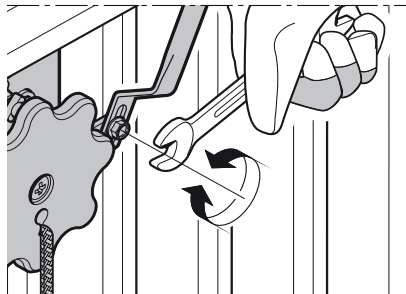
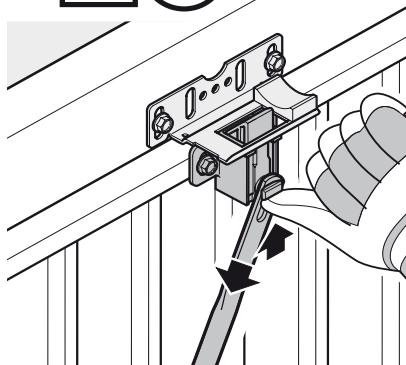
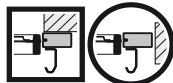

4

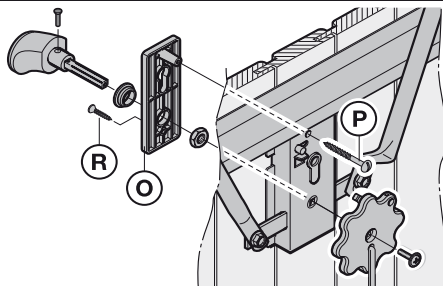

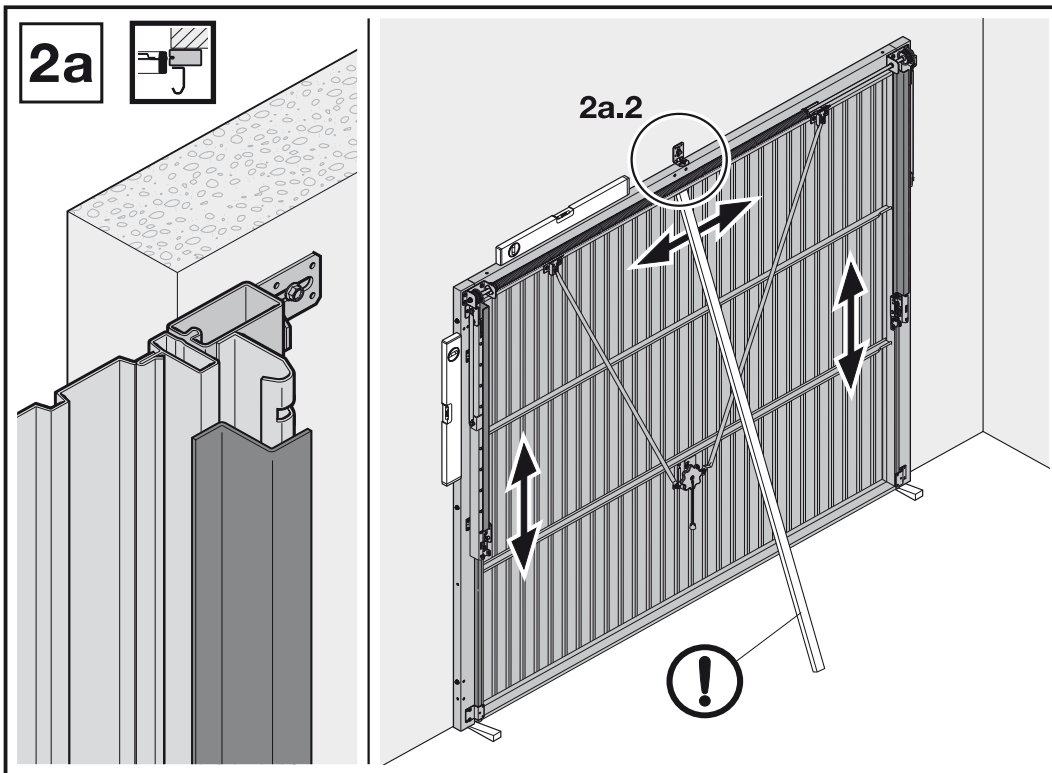

2a.1

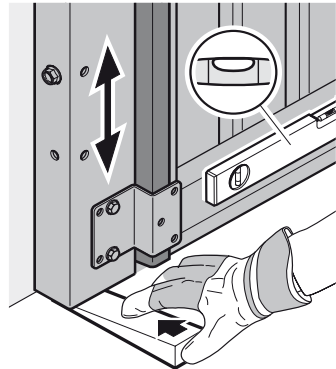
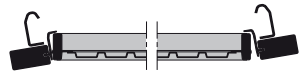
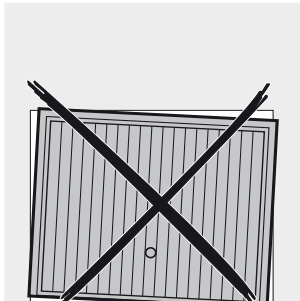
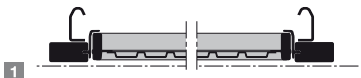
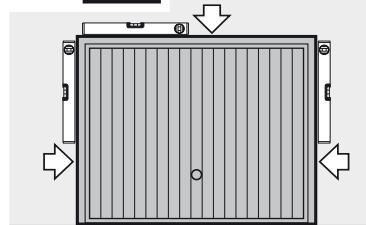

2

2a.2

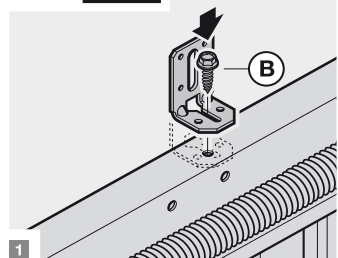

1

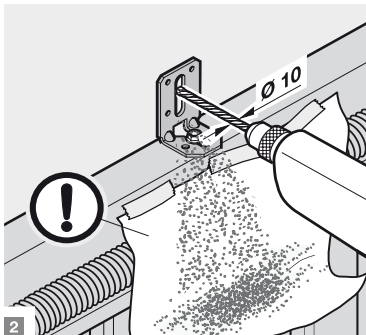

2

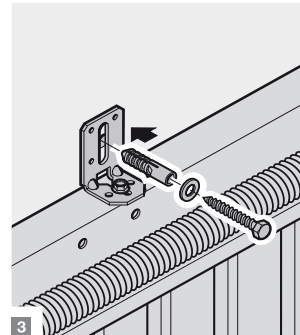

3

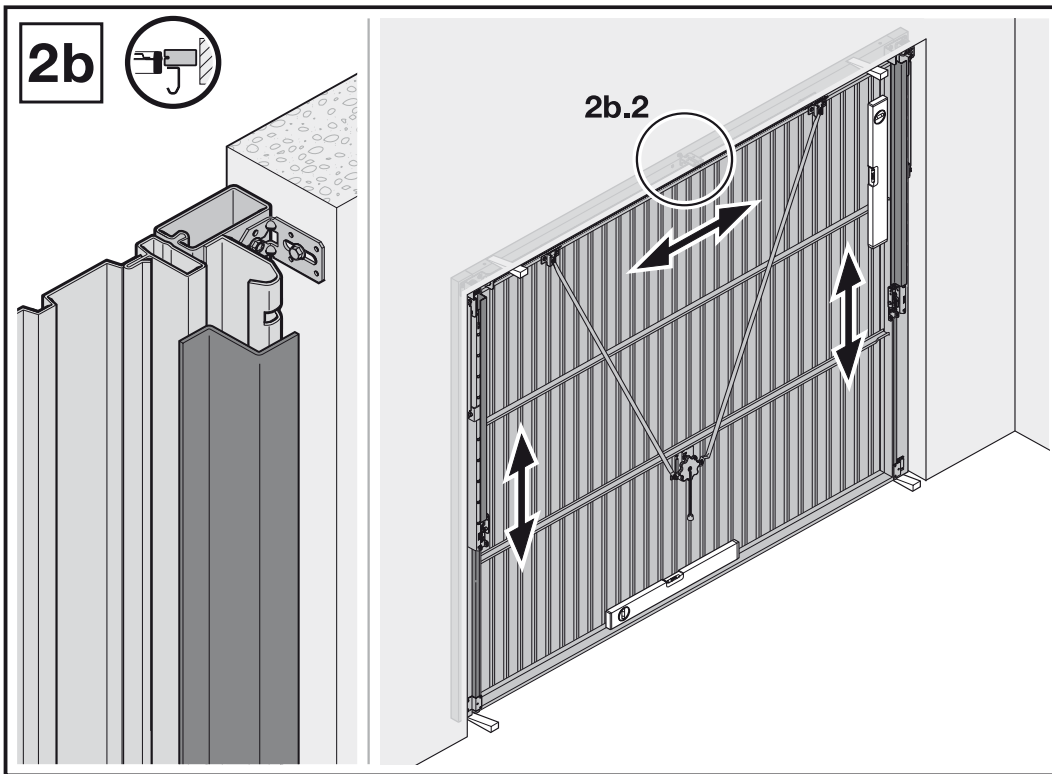

2b.1



1

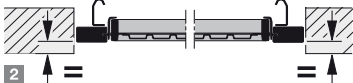
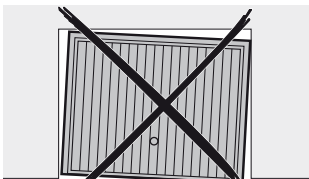
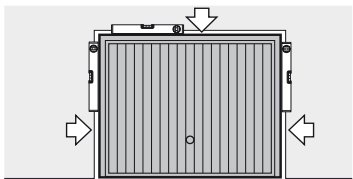

2

2

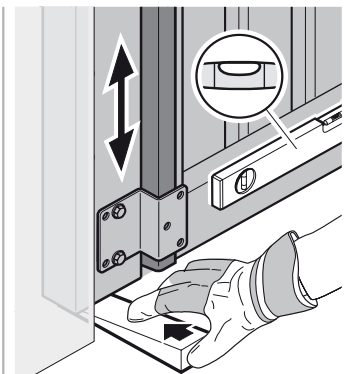

3

2b.2

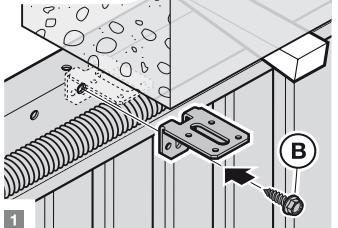

1

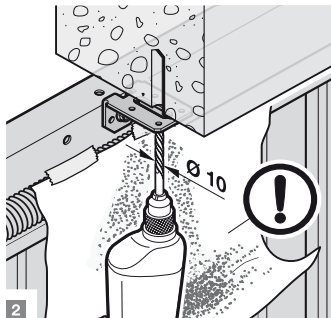

2

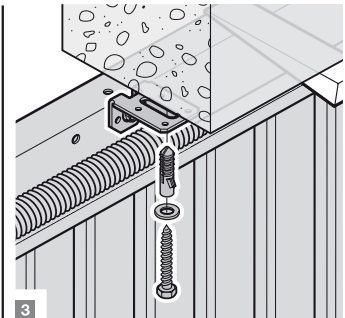

3

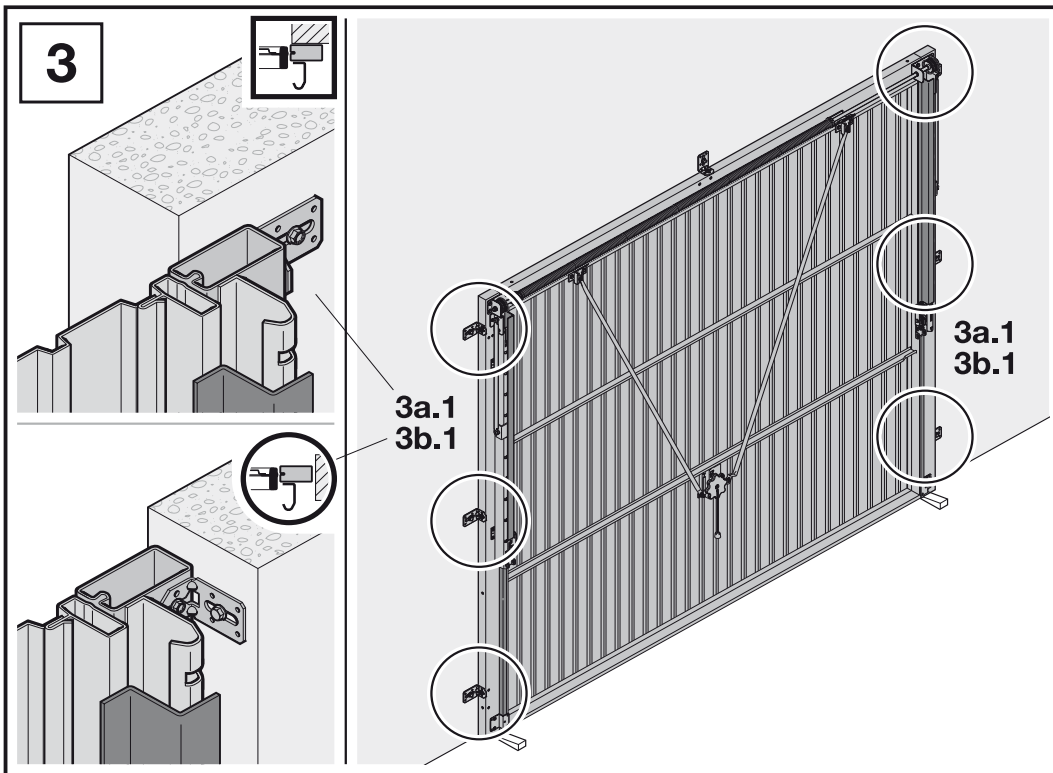

3a.1

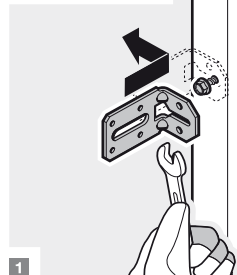

1

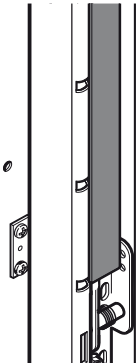

2

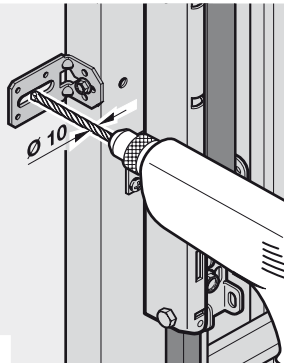

3

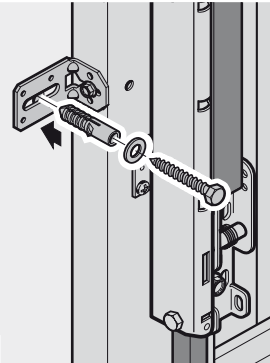

3b.1

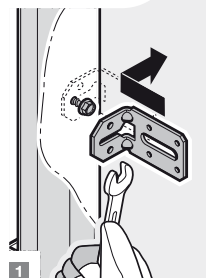

1

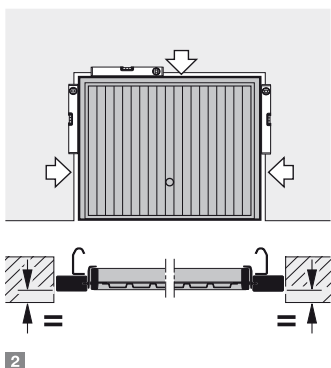

2

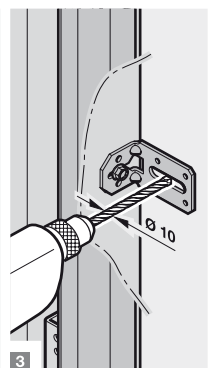

3

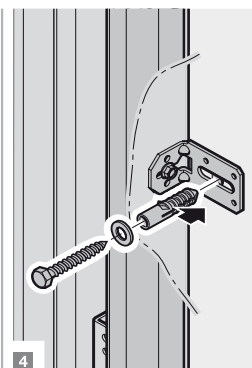

4

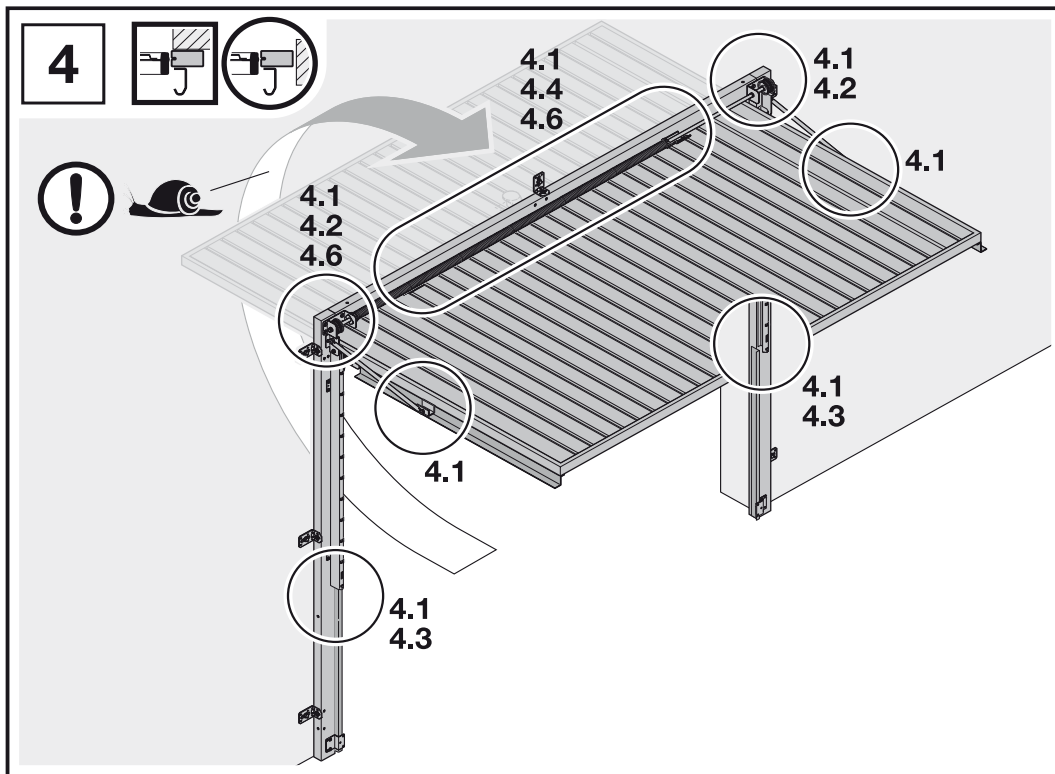

4.1

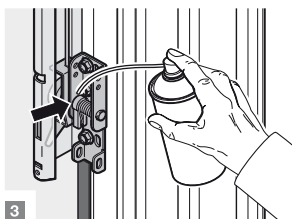
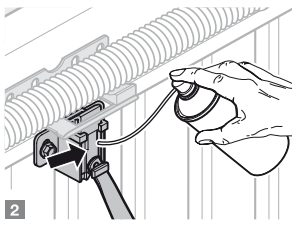
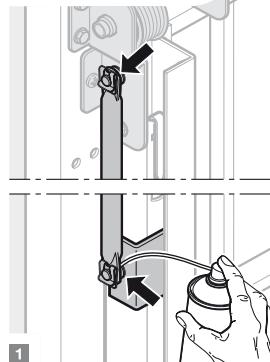

4.2

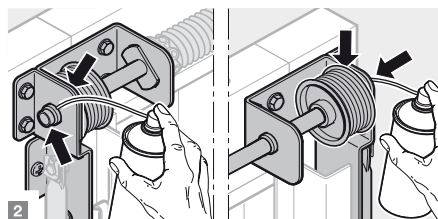
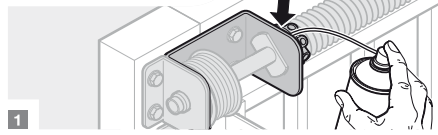

4.3

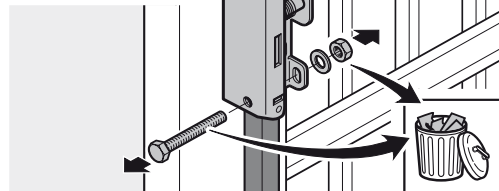

4.4

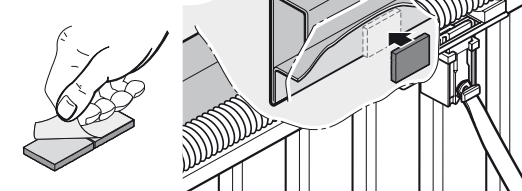

4.5

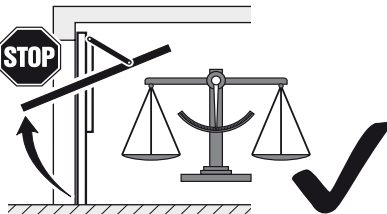
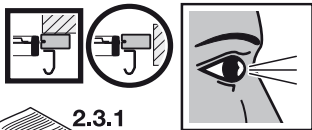

➔ 4.6

4.6

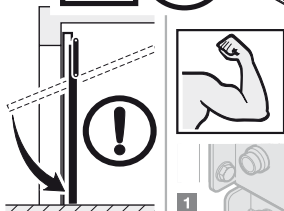

1

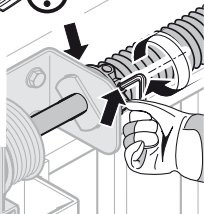

2



3

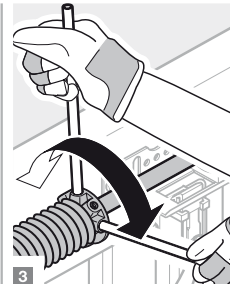

4

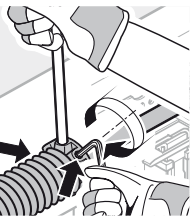

5

360°

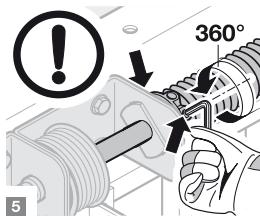

6

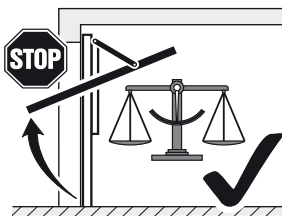

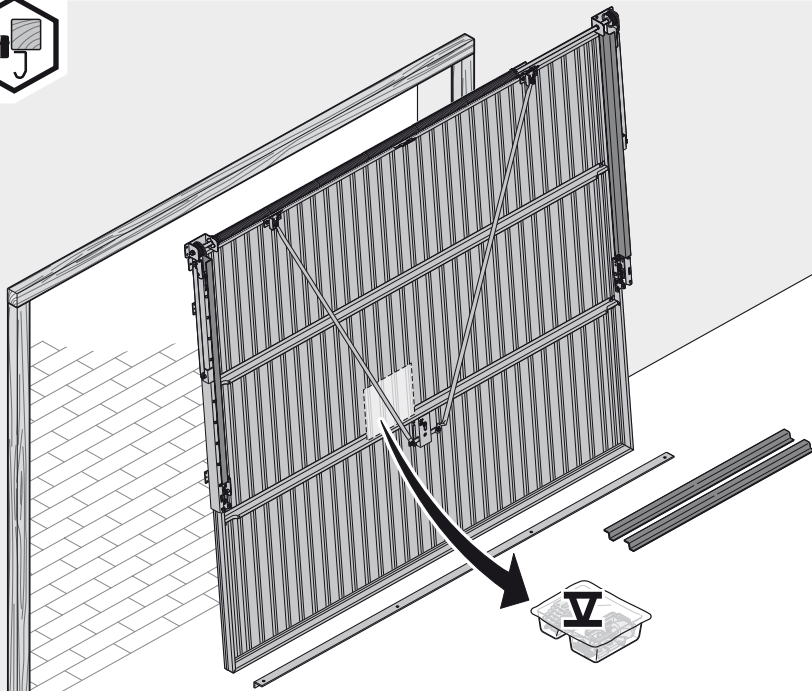

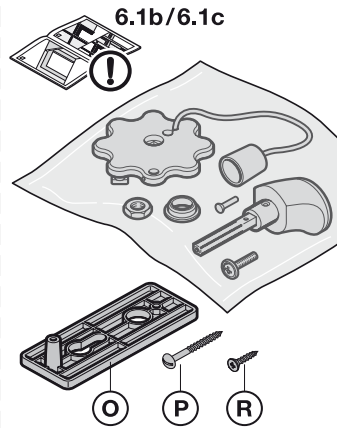
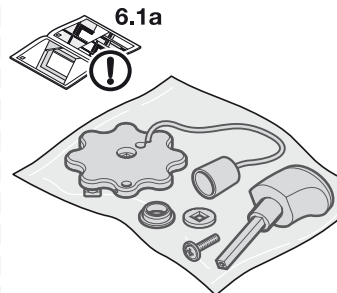
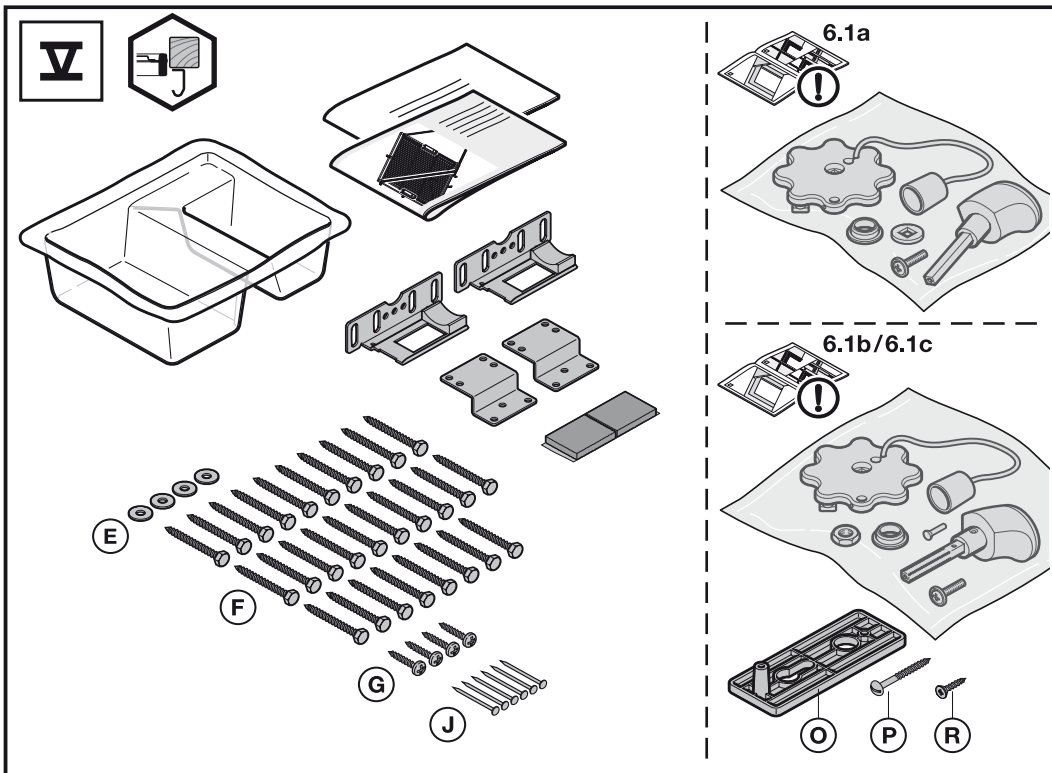

5

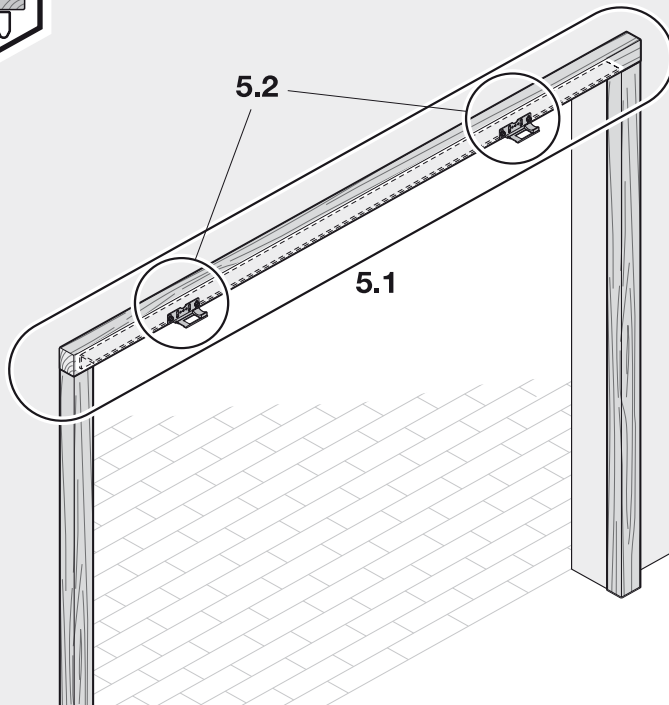

5.1

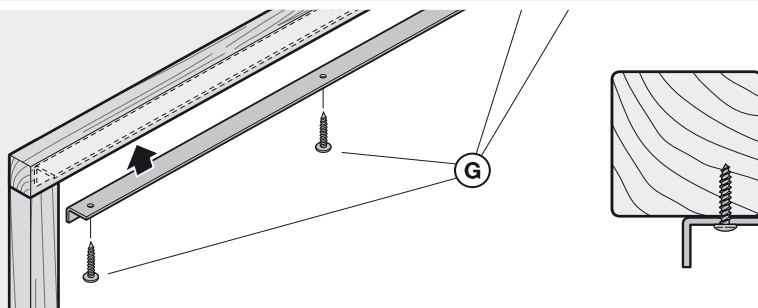

5.2

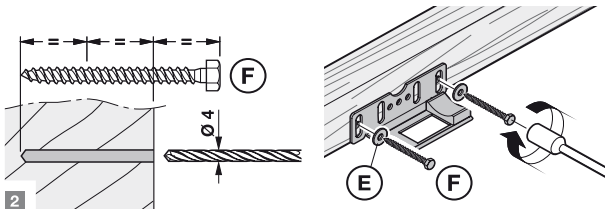
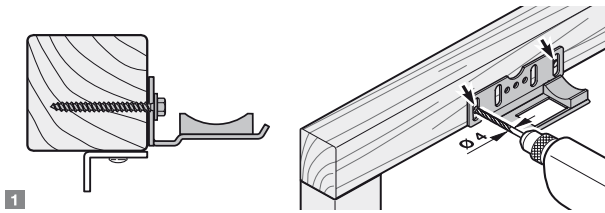
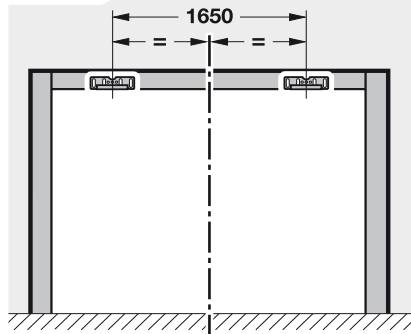

6

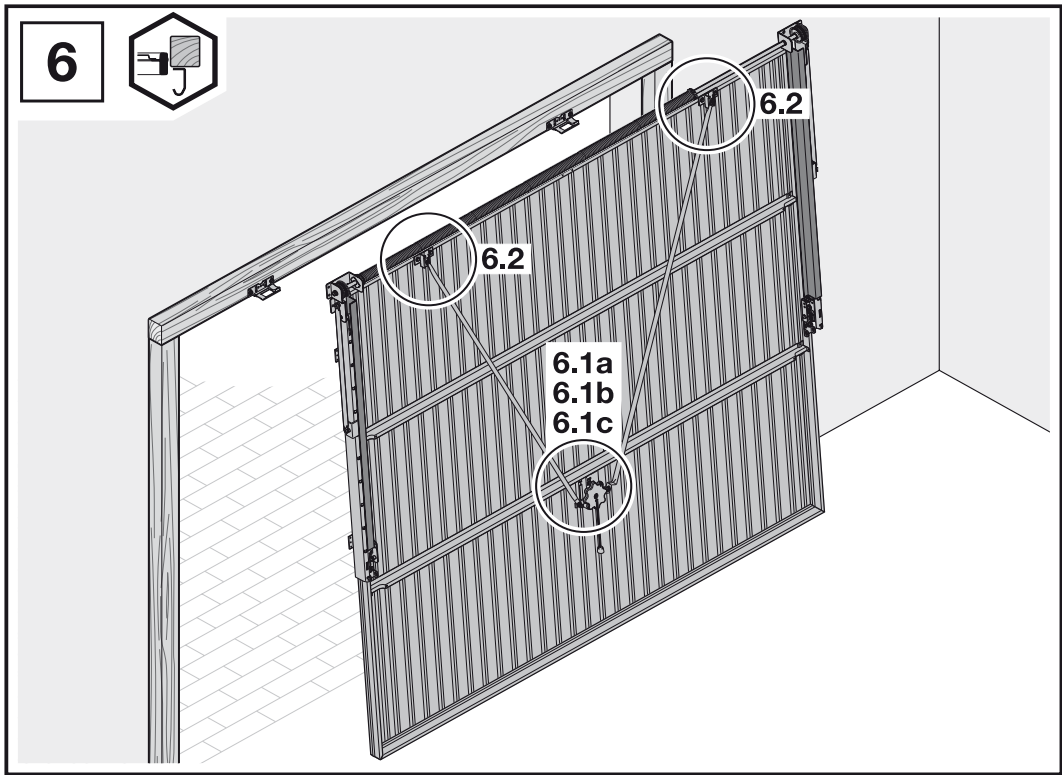

6.1a

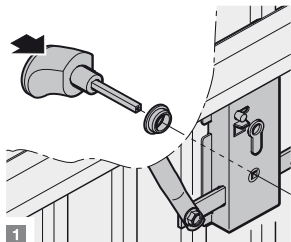
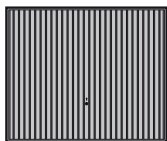

1

2.2.1

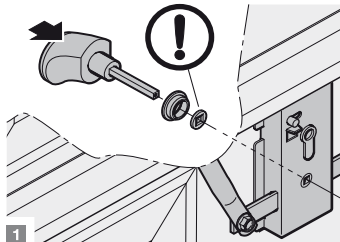
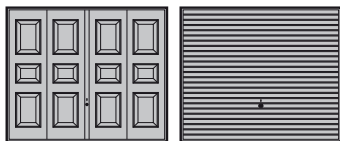

1

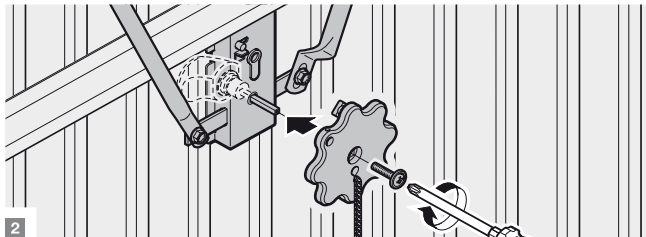

2

6.1b

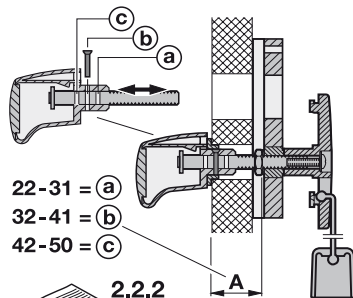

- 22-31 = a
- 32-41 = b
- 42-50 = c

2.2.2

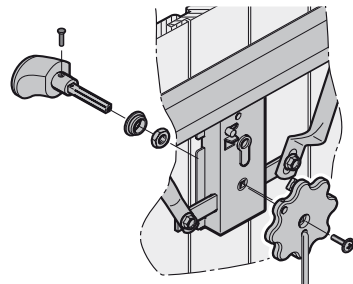

6.1c



2.2.2

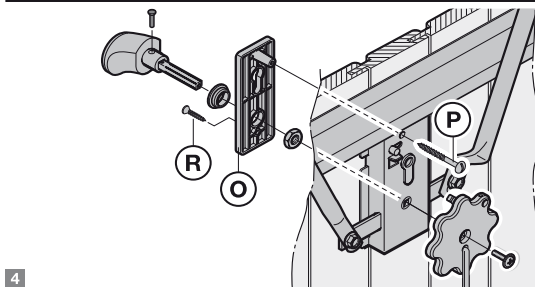
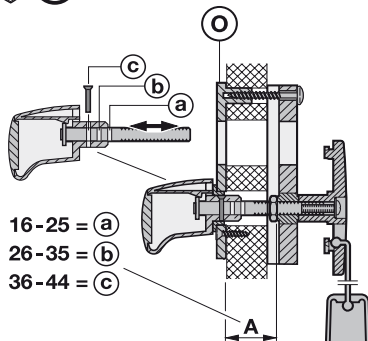
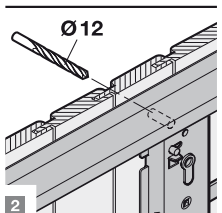
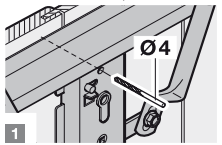

6.2

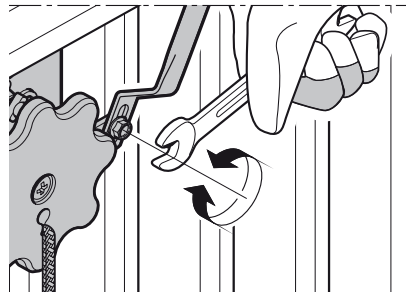
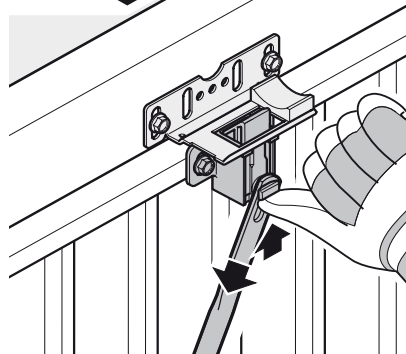

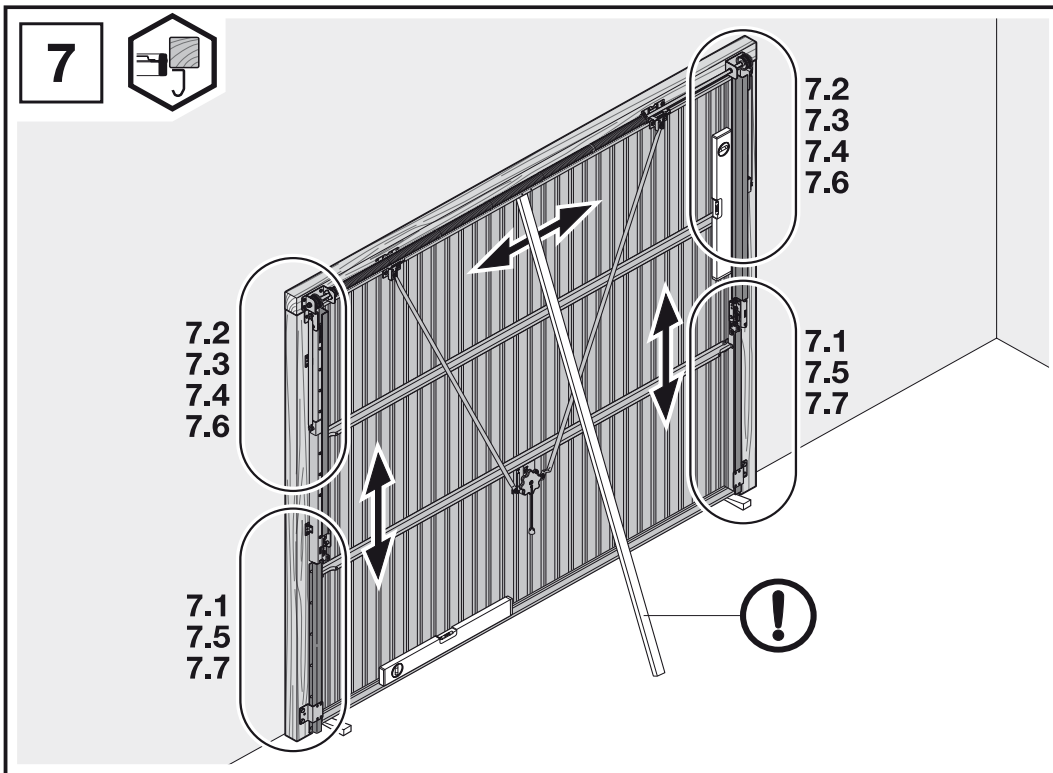

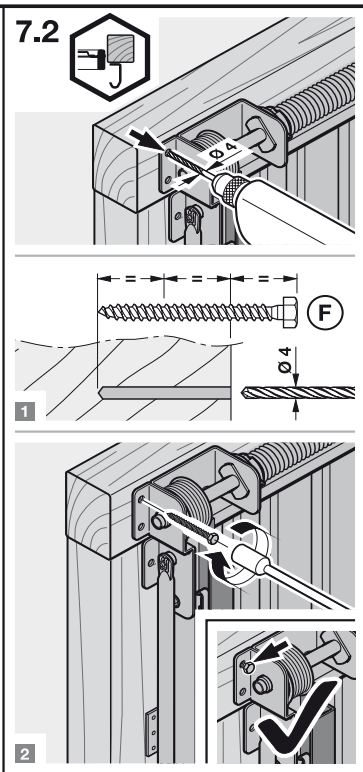
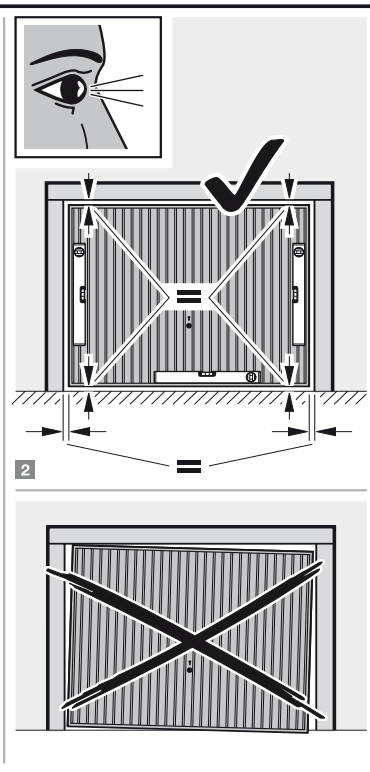
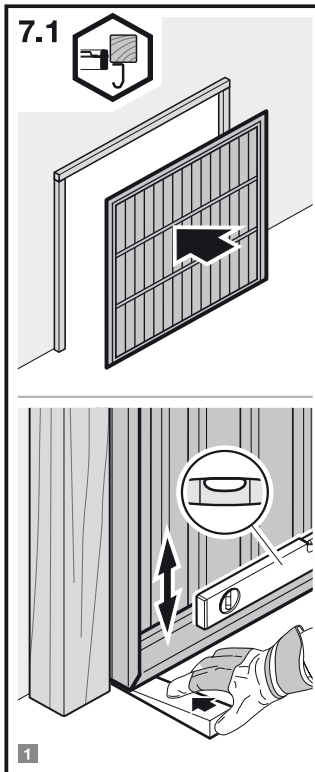

7.3

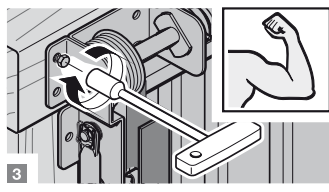
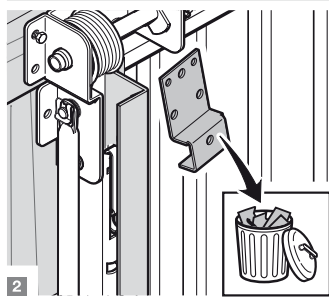
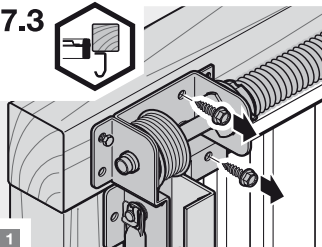

7.4

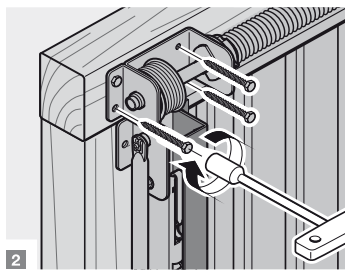
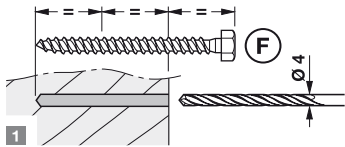
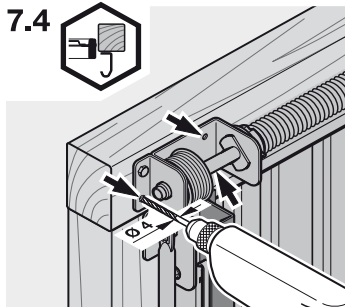

7.5

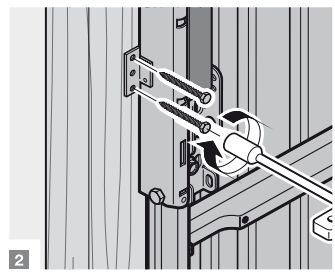
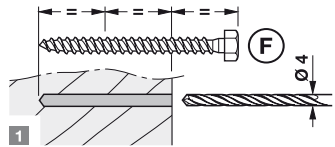
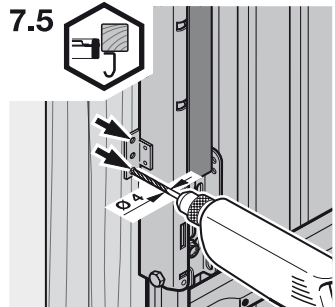

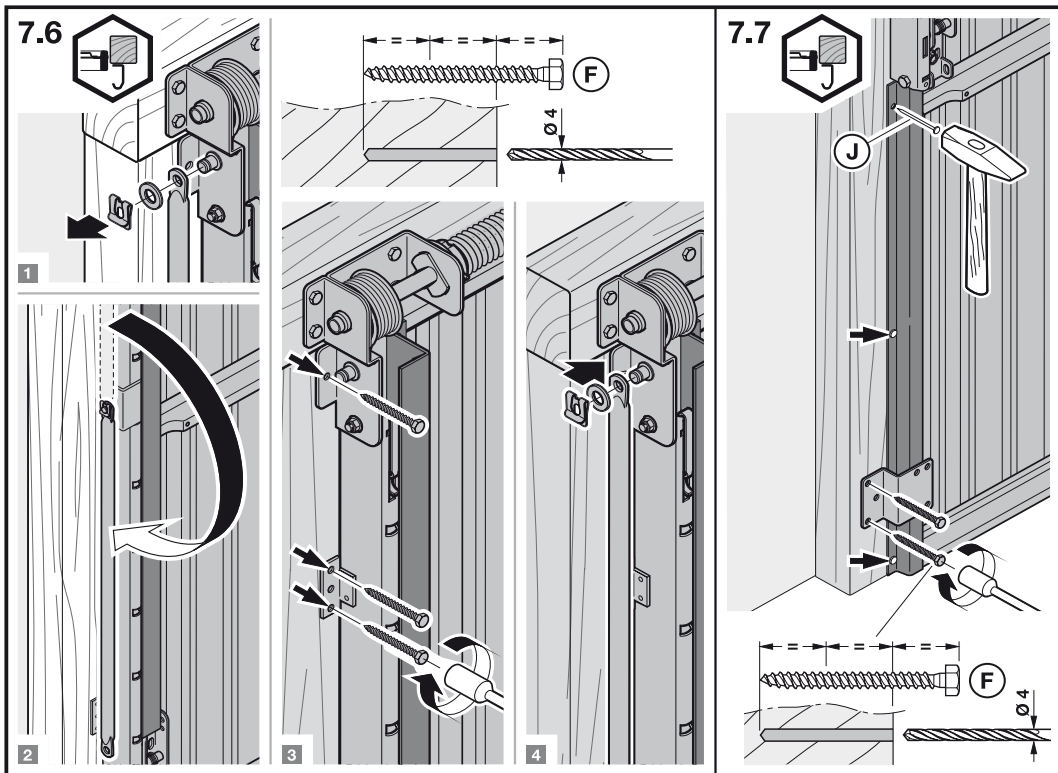

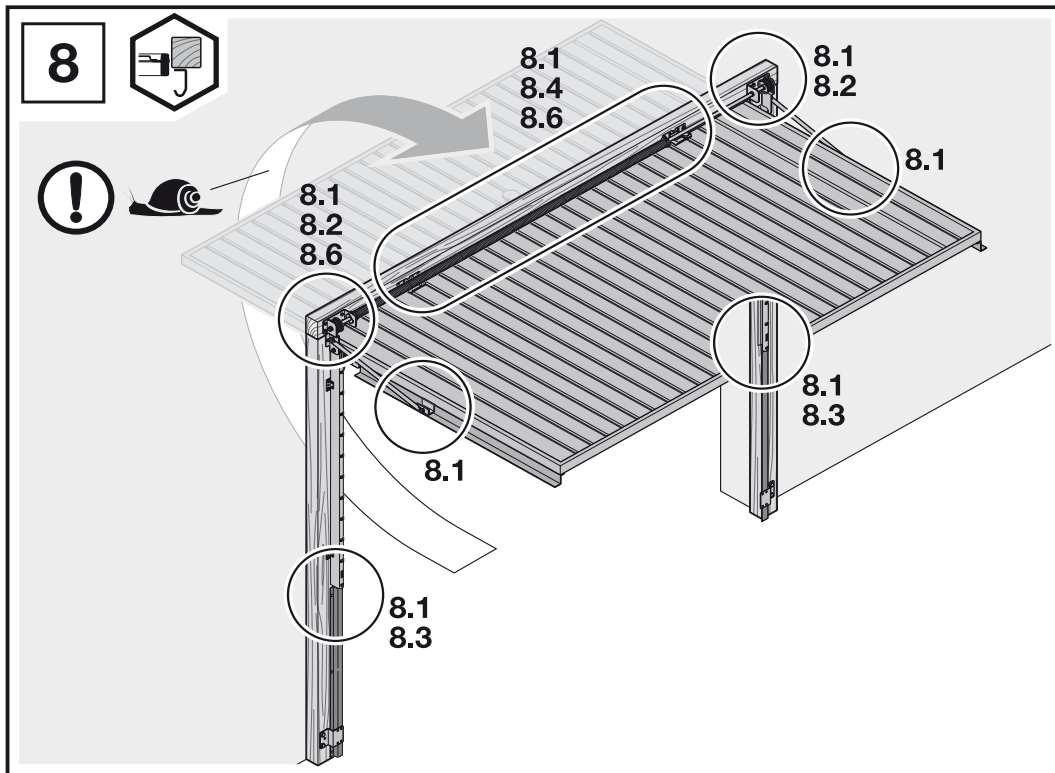

8.1

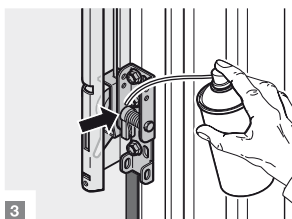
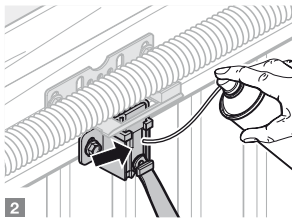
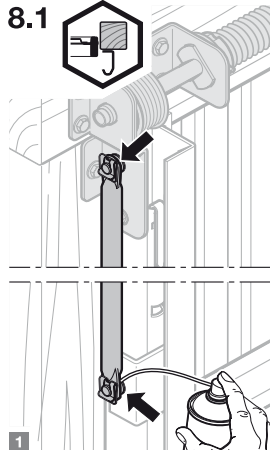

8.2

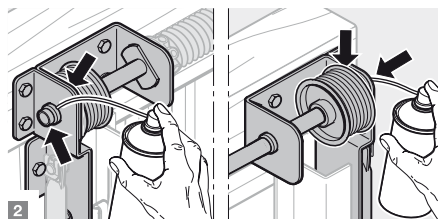
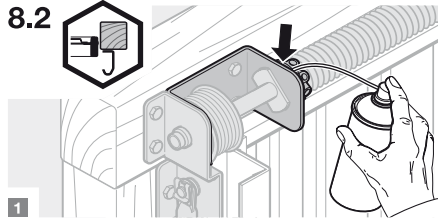

8.3

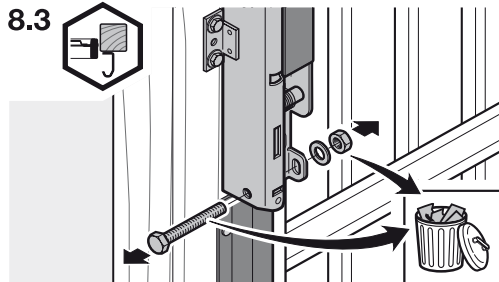

8.4

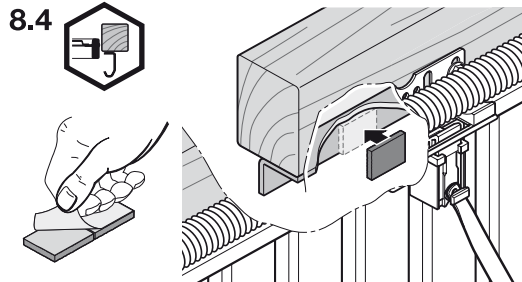

8.5

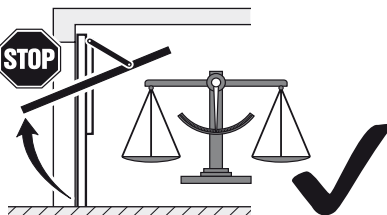

➔ 8.6



8.6

