

631087 / 01.2013

DE**Anleitung für Montage und Wartung**

ThermoPro / ThermoPro Plus / MZ Thermo / KSi Thermo

EN**Fitting and Maintenance Instructions**

ThermoPro / ThermoPro Plus / MZ Thermo / KSi Thermo

FR**Instructions de montage et d'entretien**

ThermoPro / ThermoPro Plus / MZ Thermo / KSi Thermo

ES**Instrucciones de montaje y mantenimiento**







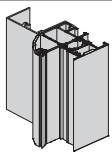
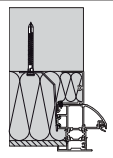
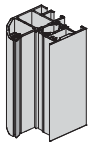
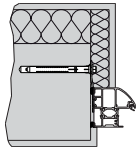
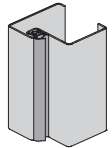
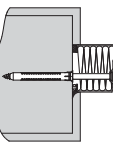
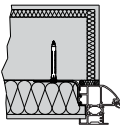
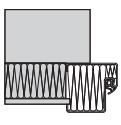
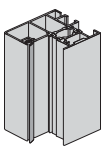
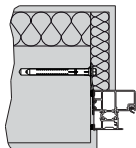
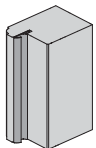
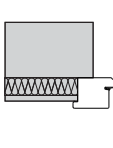
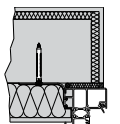
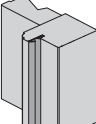
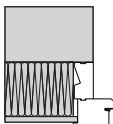
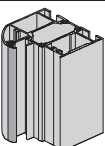
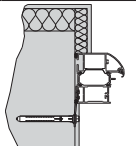
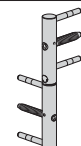

ThermoPro / ThermoPro Plus / MZ Thermo / KSi Thermo

RU**Инструкция по монтажу и техническому обслуживанию**





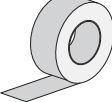
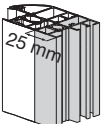
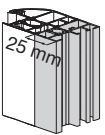
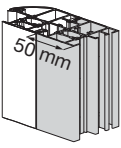
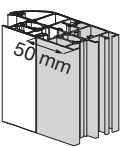

ThermoPro / ThermoPro Plus / MZ Thermo / KSi Thermo

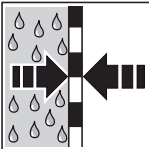

+**NL** NEDERLANDS**IT** ITALIANO**PT** PORTUGUÊS**PL** POLSKI**HU** MAGYAR**CS** ČESKY**SL** SLOVENSKY**NO** NORSK**SV** SVENSKA**FI** SUOMI**DA** DANSK**SK** SLOVENSKO**TR** TÜRKÇE**LT** LIETUVIŲ KALBA**ET** EESTI**LV** LATVIEŠU VALODA**HR** HRVATSKI**SR** SRPSKI**EL** ΕΛΛΗΝΙΚΑ**RO** ROMÂNĂ**BG** БЪЛГАРСКИ

THERMOPRO / THERMOPRO PLUS / MZ THERMO / KSI THERMO

			3			F	44
		TPS	20				46
		TPS	22			F	48
		TPS MZ Thermo KSi Thermo	20			F	50
		TPS MZ Thermo	22			F	52
		TPS Plus	23				53
 WK2	 RC2	TPS KSi Thermo	20				54
		TPS Plus	23				
		TPS 080 TPS 081	26				55
		TPS	30				56
		TPS Plus	35				
			40				57
 25 mm		TPS	41				
 50 mm		TPS	43				

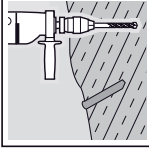
THERMOPRO / THERMOPRO PLUS / MZ THERMO / KSI THERMO

	DE wichtiger Hinweis zur Vermeidung von Sachschäden
	EN Important note for avoiding damage to property
	FR Remarques importantes pour éviter les dommages matériels
	RU Важное замечание по предотвращению травм и материального ущерба
	DE zulässige Anordnung oder Tätigkeit
	EN Permissible arrangement or activity
	FR Disposition ou activité autorisée
	RU Допустимая планировка или деятельность
	DE unzulässige Anordnung oder Tätigkeit
	EN Non-permissible arrangement or activity
	FR Disposition ou activité interdite
	RU Недопустимая планировка или деятельность
	DE dampfdiffusionsdicht
	EN vapour diffusion proof
	FR Imperméable à la diffusion de vapeur
	RU Паронепроницаемое исполнение
	DE dampfdiffusionsoffen
	EN open to vapour diffusion
	FR Perméable à la diffusion de vapeur
	RU Паропроницаемое исполнение
	DE Haus Innenbereich
	EN House interior
	FR Intérieur
	RU Внутреннее пространство здания
	DE Haus Aussenbereich
	EN House exterior
	FR Extérieur
	RU Внешнее пространство здания
	DE Tauwasserbildung
	EN Condensation
	FR Formation de condensation
	RU образование конденсата
	DE Bohren
	EN Drilling
	FR Perçage
	RU Сверление

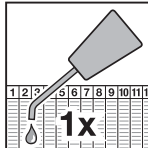
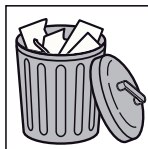
	DE Verschraubung handfest anziehen
	EN Tighten the screws by hand
	FR Serrage des vis à la main
	RU Затянуть вручную резьбовое соединение
	DE Verschraubung fest anziehen
	EN Tighten the screws firmly
	FR Serrage des vis à fond
	RU Крепко затянуть резьбовое соединение
	DE prüfen
	EN Inspect
	FR Vérification
	RU Проверить
	DE Wartung jährlich
	EN Annual maintenance
	FR Maintenance annuelle
	RU ежегодное техническое обслуживание
	DE Bauteil oder Verpackung entfernen und entsorgen
	EN Remove and dispose of component or packaging
	FR Retrait de l'élément de construction ou du conditionnement et élimination
	RU Убрать и утилизировать деталь или упаковку

DE DEUTSCH

wir freuen uns darüber, dass Sie sich für ein Produkt aus unserem Hause entschieden haben.

Zu dieser Anleitung

Diese Anleitung gliedert sich in einen Text- und einen Bildteil. Den Bildteil finden Sie im Anschluss an den Textteil.

Lesen und beachten Sie diese Anleitung. In ihr stehen wichtige Informationen zum Produkt. Beachten Sie insbesondere alle Sicherheits- und Warnhinweise.

Bewahren Sie diese Anleitung sorgfältig auf!

Verwendete Warnhinweise**ACHTUNG**

Kennzeichnet eine Gefahr, die zur **Beschädigung oder Zerstörung des Produkts** führen kann.

Halten Sie sich beim Einbau der Tür an den „RAL-Leitfaden zur Montage:2010-03“.

Ermittlung der Türposition

Die Türposition in Abhängigkeit der örtlichen Befestigungsmöglichkeiten, der Wandart und der erforderlichen Rand- und Achsabstände für die Dübel festlegen. Bei monolithischem oder einschaligem Mauerwerk die Tür möglichst weit zur Gebäudeinnenseite positionieren. Isothermenverlauf darf nicht gestört bzw.

THERMOPRO / THERMOPRO PLUS / MZ THERMO / KSI THERMO

unterbrochen werden. Die Tür ist so zu positionieren, dass Wärmebrücken im Wandanschluss vermieden werden.

Baukörperanschluss

1. Raum zwischen Türrahmen und Mauerwerk mit Isoliermaterial auffüllen (z.B. Glas- oder Steinwolle).
2. Rundschnur eindrücken.
3. Fuge innen mit Silikon dampfdiffusionsdicht versiegeln.
4. Fuge außen mit vorkomprimierten Bändern dampfdiffusionsoffen herstellen.

Oberflächenausführung

Die Türoberfläche ist mit einer Nasslackierung bzw. Folienbeschichtung versehen. *Diese Beschichtung verleiht der Türoberfläche folgende Eigenschaften:*

- Korrosionsschutz
- Farbechtheit
- Schutz vor Umgebungseinflüssen

Oberfläche überlackieren (Nachlackieren nicht folienbeschichteter Oberflächen):

1. Oberfläche anschleifen.
2. Angeschliffene Fläche gründlich reinigen.
3. Direkt 2K-PUR-Decklackierung oder 2K-EPOXY-Haftgrund aufbringen und mit handelsüblichen Kunstharz-Lacken streichen.

ACHTUNG**Ungeeignetes Pflegemittel**

Die Oberfläche der Tür oder angrenzender Bauteile können durch aggressive, ätzende oder schmirgelnde Stoffe wie zum Beispiel Säuren oder durch Stahlbürsten beschädigt werden.

- ▶ Verwenden Sie zur Pflege der Haustür nur handelsübliche Pflegemittel und weiche Lappen oder Tücher.
- ▶ Beachten sie beim Pflegemittel auch stets die Herstellerhinweise.

- ▶ Bewegliche Beschlagsteile einmal im Jahr ölen oder fetten. Nur säurefreies Öl oder Vaseline verwenden.
- ▶ Unter bestimmten klimatischen Bedingungen kann Tauwasserbildung am Element auftreten.

EN ENGLISH

Dear Customer,

We are delighted that you have chosen a quality product from our company.

About These Instructions

These instructions are divided into a text section and an illustrated section. The illustrated section can be found after the text section.

Read and follow these instructions carefully. They contain important information concerning the product. Please pay particular attention to all safety and warning notices.

Keep these instructions in a safe place for future reference.

Warnings used**ATTENTION**

Indicates a danger that can lead to **damage or destruction of the product.**

Determination of Door Position

Determine the door position depending on the on-site fastening options, type of wall and the required edge and centre line spacing for the plug. If possible, position the door so that it is within the insulation layer of the wall. With monolithic or single-shell masonry, position the door as close as possible towards the building interior side. Do not disturb or interrupt the isothermal lines. Position to door so that there are no thermal bridges in the wall connection.

Connection to Building Structure

1. Fill the space between the door frame and masonry with insulation material (such as fibreglass or mineral wool).
2. Push in the round cord.
3. Seal the groove on the interior with silicone so that it is impervious to vapour diffusion.
4. Make the exterior groove open to vapour diffusion with pre-compacted strips.

Surface

The door surface is furnished with a wet paint coating or a foil-coating. This coating provides the door surface with the following properties:

- Corrosion protection
- Colour fastness
- Protection from environmental influences

Varnishing the surface (Repainting non-foil-coated surfaces):

1. Sand the surface.
2. Clean the sanded surface thoroughly.
3. Apply 2K-PUR paint finish or 2K-EPOXY etch primer directly and paint with conventional synthetic resin paints.

ATTENTION**Unsuitable care products**

The door surface and adjacent components can be damaged by aggressive, corrosive or abrasive materials such as acids or steel brushes.

- ▶ Only use conventional care products, as well as soft cloths or towels, to maintain the entrance door.
- ▶ Always take note of the manufacturer information for the care products.

- ▶ Oil or lubricate movable fitting parts once a year. Only use acid-free oil or vaseline.
- ▶ Under certain climatic conditions condensation may appear on the element.

FR FRANÇAIS

Cher client,

Nous vous remercions d'avoir opté pour un produit de la société Hörmann.

A propos de ce mode d'emploi

Cette notice se compose d'une partie texte et d'une partie illustrée. Vous trouverez cette dernière à la fin de la partie texte.

Lisez attentivement et suivez les présentes instructions. Elles contiennent des informations importantes concernant

		TPS		TPS Plus	
	CE	✓	✓	✓	✓
	EN 14351-1	✓	✓	✓	✓
	EN 12400	✓	✓	✓	✓
	EN 12219	✓	✗	✓	✓
	EN ISO 140-3 EN ISO 717-1	✓	✓	✓	✓
	EN 12208	✓	✗	✓	✓
	EN 1627	✓	✗	✓	✓
	EN 13049 EN 12217	✓	✓	✓	✓
	EN 12210 EN 12207	✓	✓	✓	✓
	EN ISO 12567-1 EN ISO 10077-1	✓	✓	✓	✓

ACHTUNG / ATTENTION / ATTENTION / OPGELET / ATENCIÓN / ATTENZIONE / ATENÇÃO / UWAGA / VIGYÁZAT / POZOR / ВНИМАНИЕ / POZOR / NB! / OBS! / VAROITUS / ВЕМÆРК! / POZOR / ДІККАТ / DÈMESIO! / TÄHELEPANU / UZMANĪBU! / PAŽNJA / PAŽNJA / ΠΡΟΣΟΧΗ / ATENȚIE / ВНИМАНИЕ

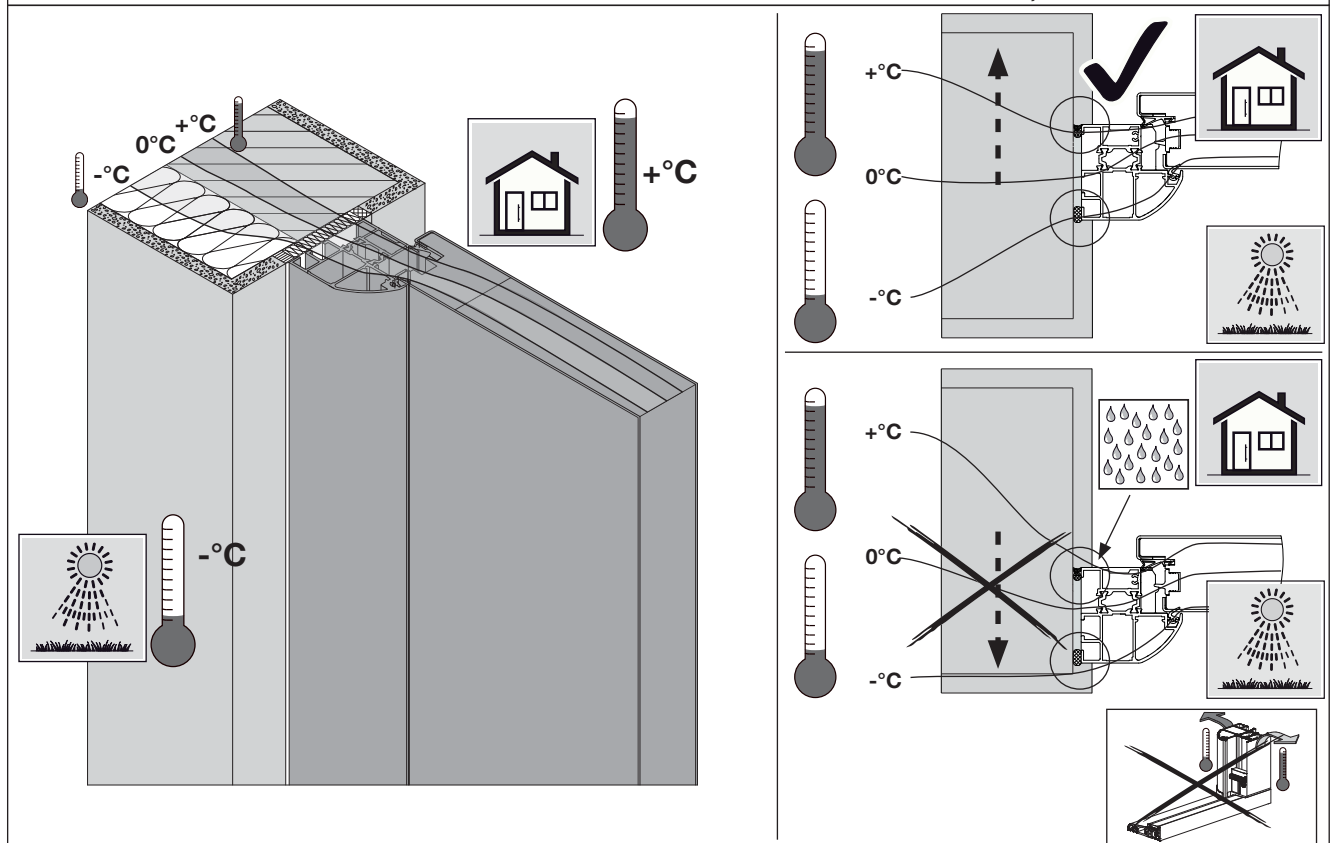

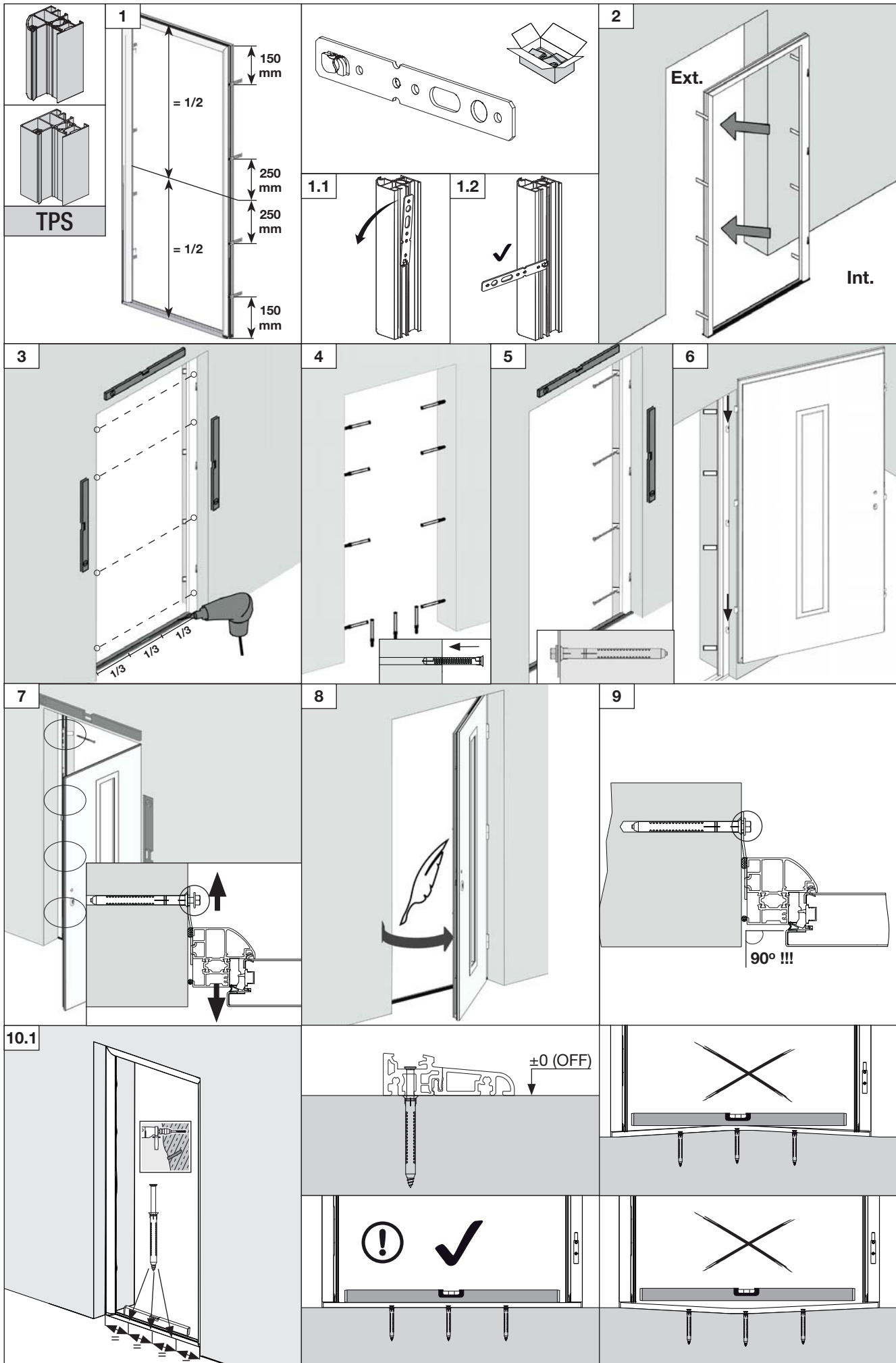

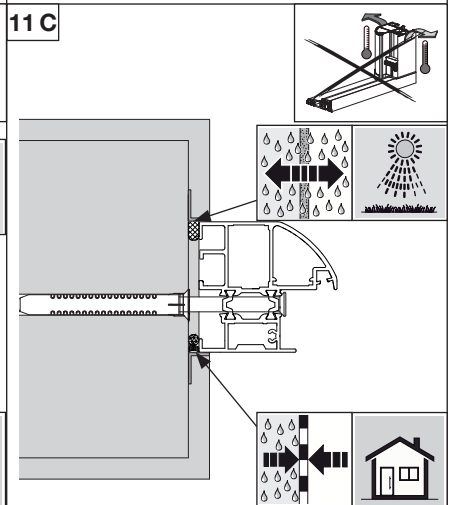
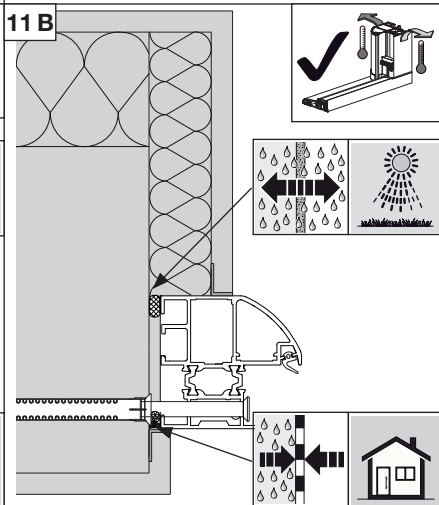
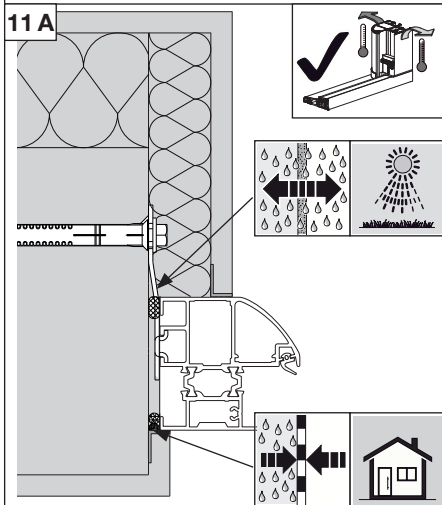
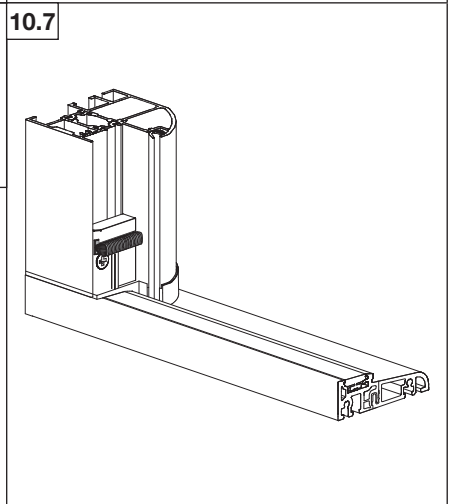
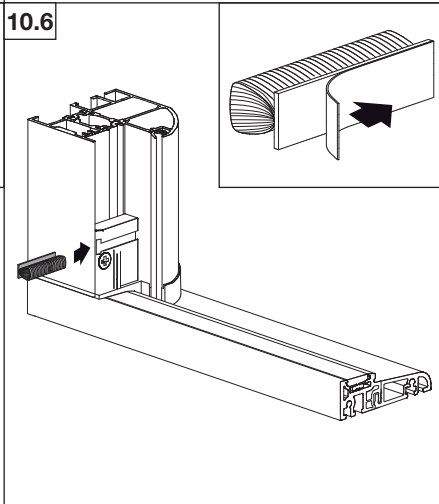
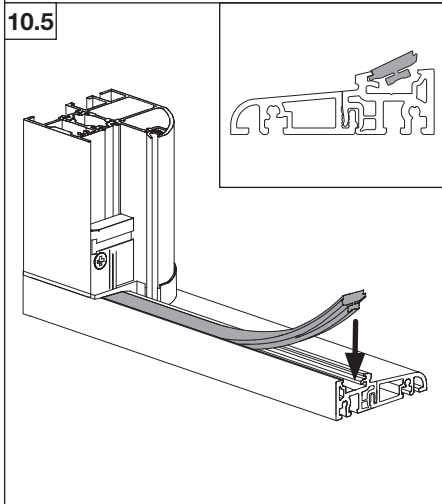
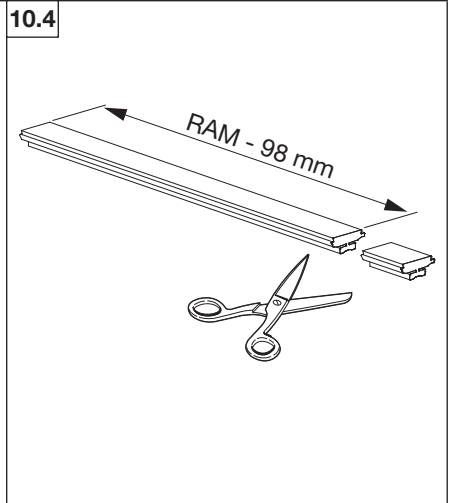
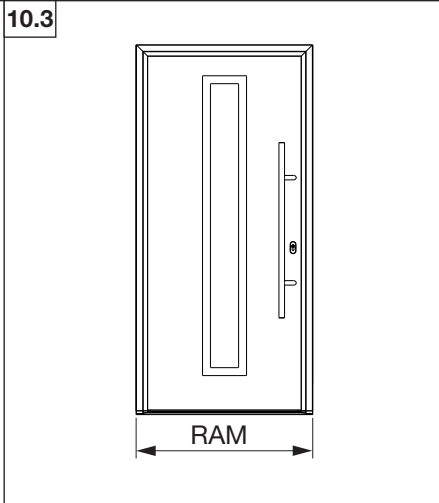
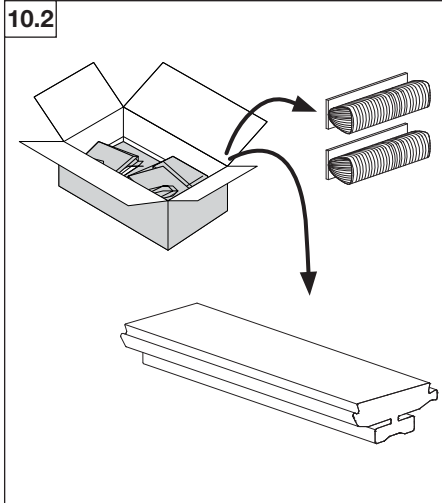

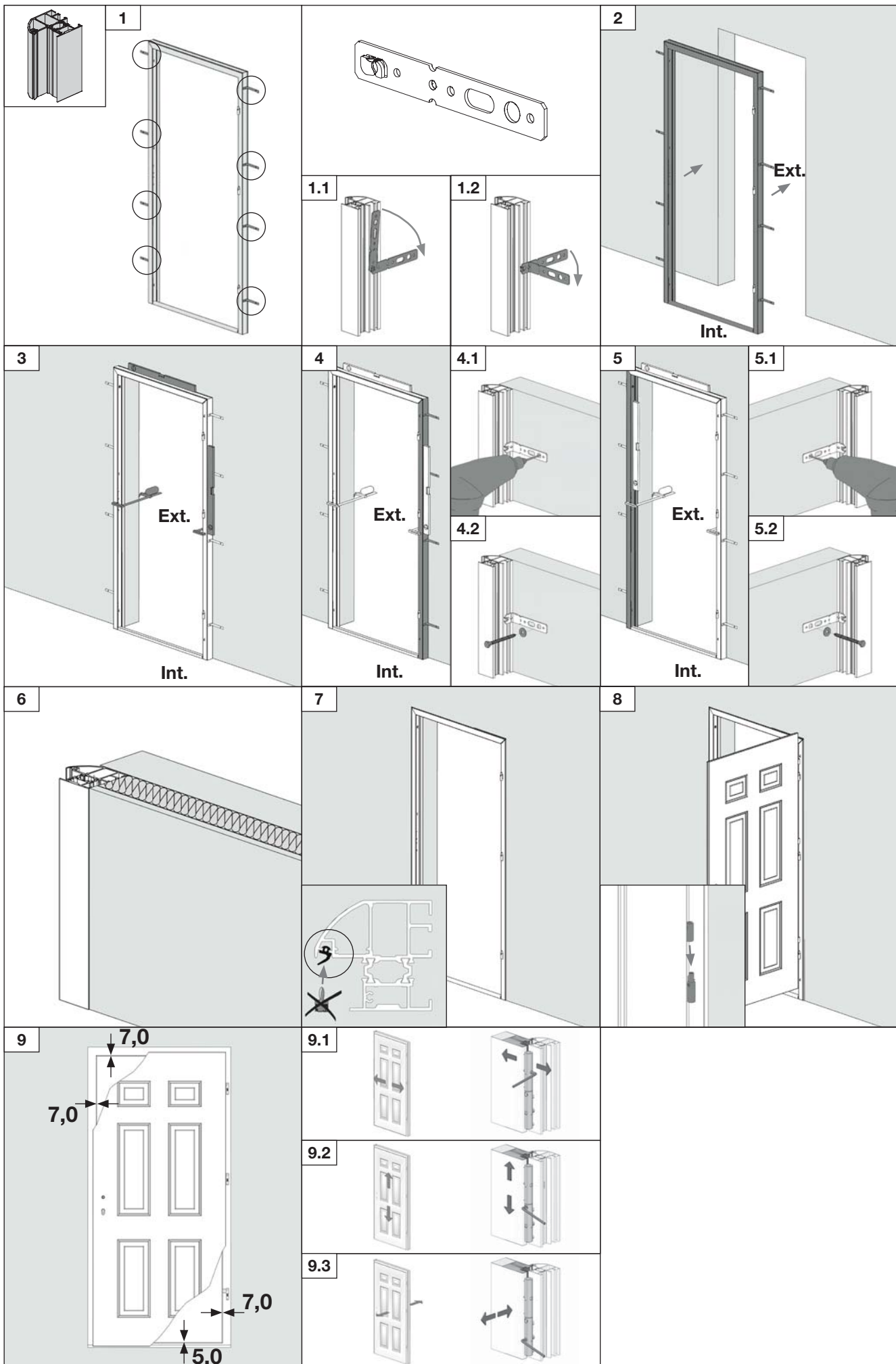

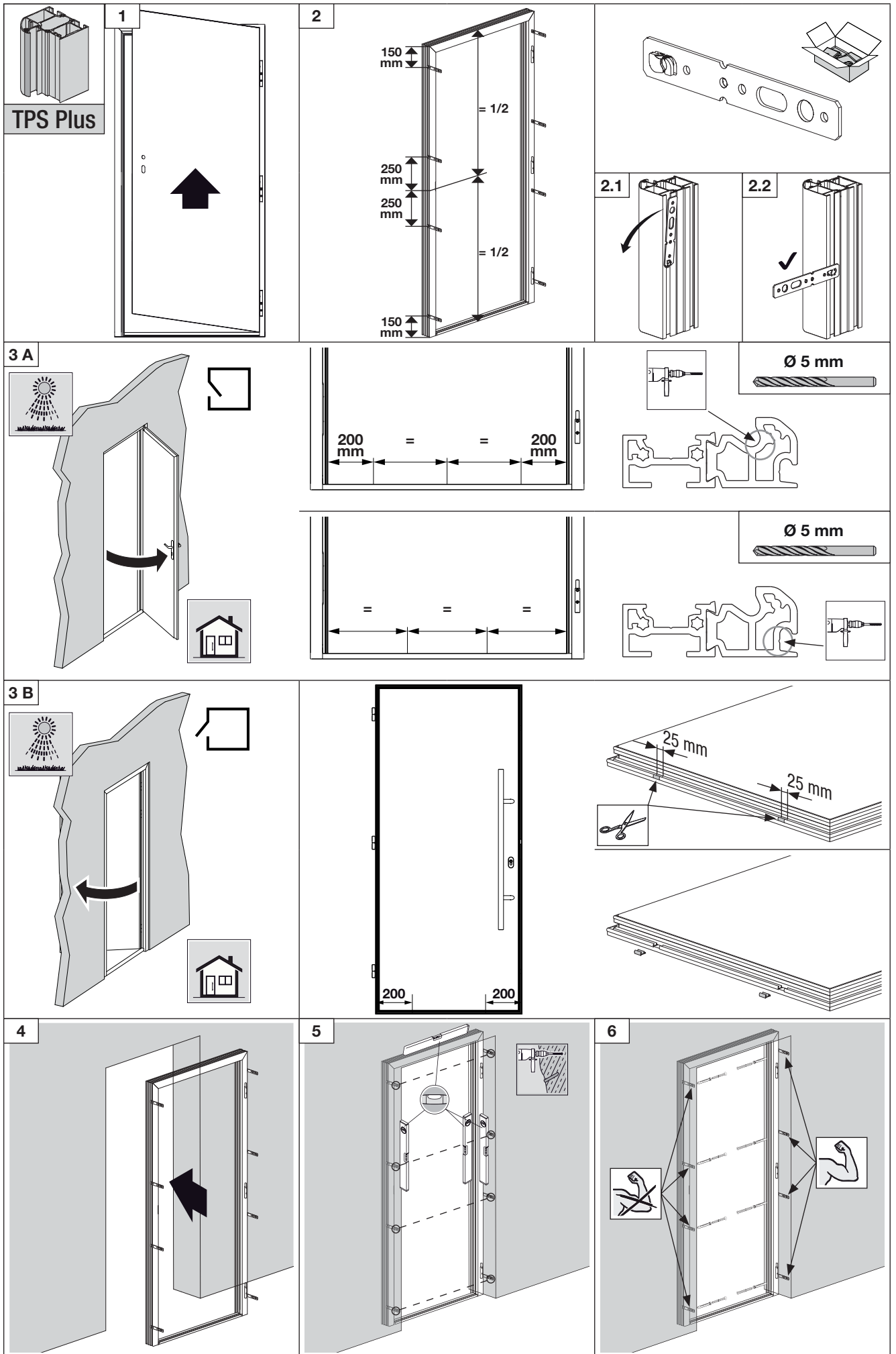

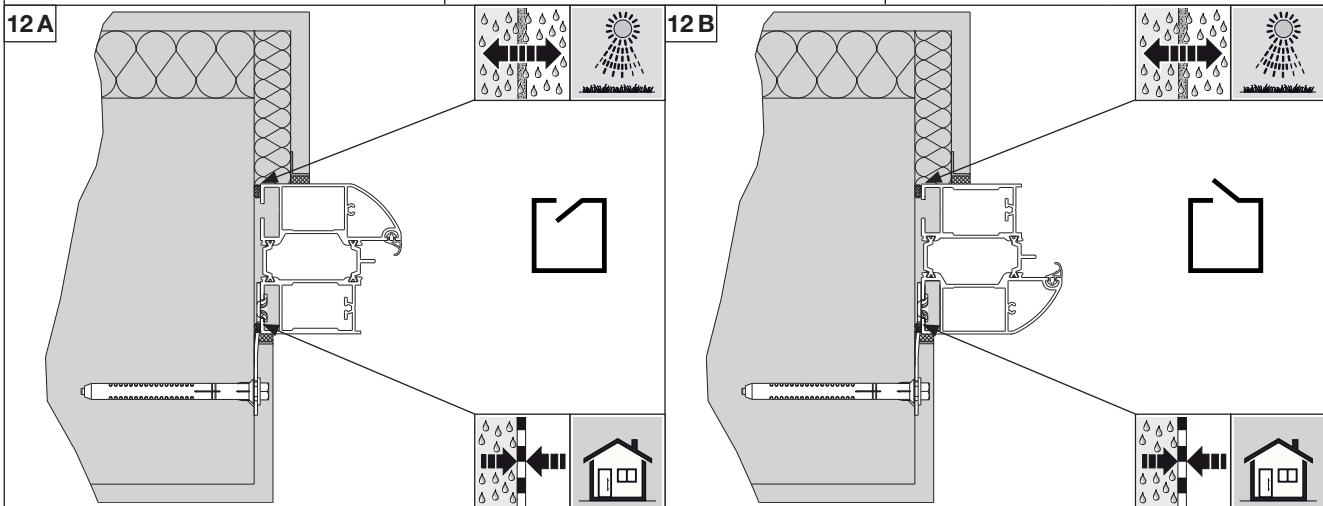
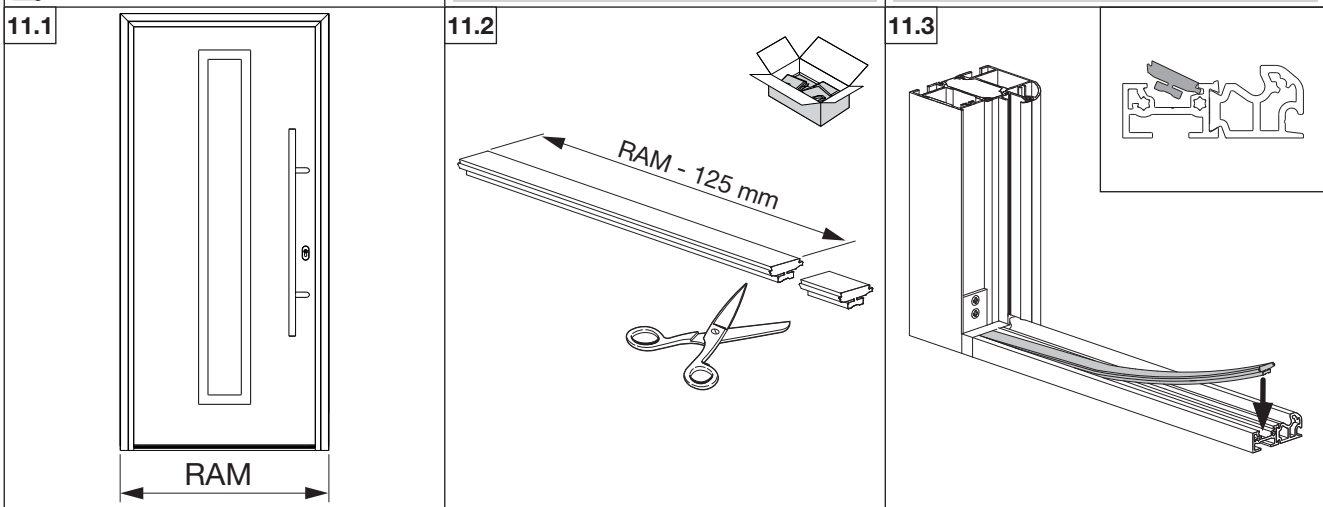
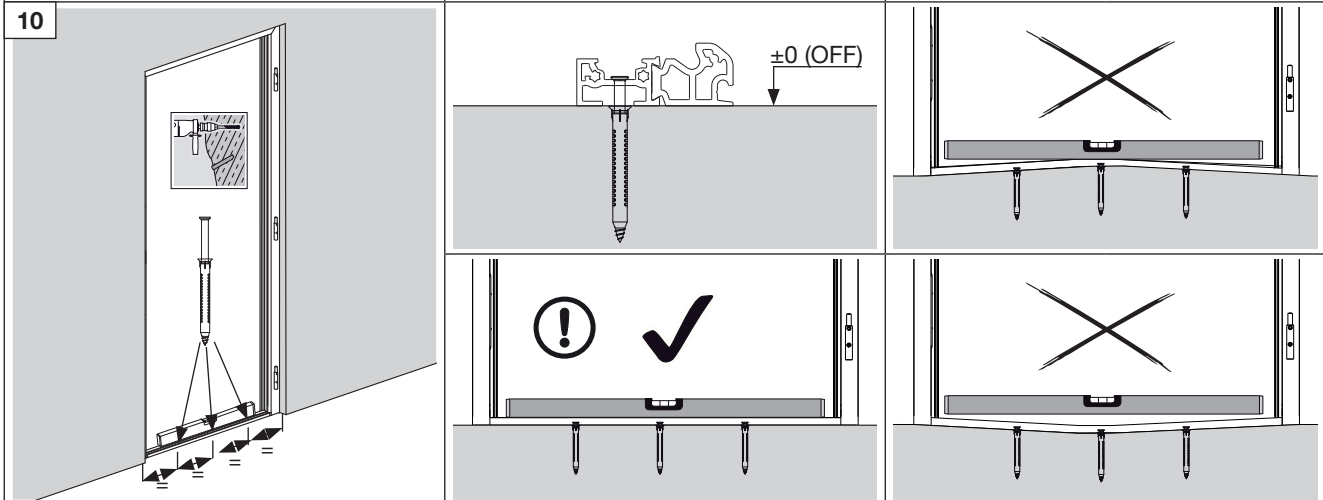
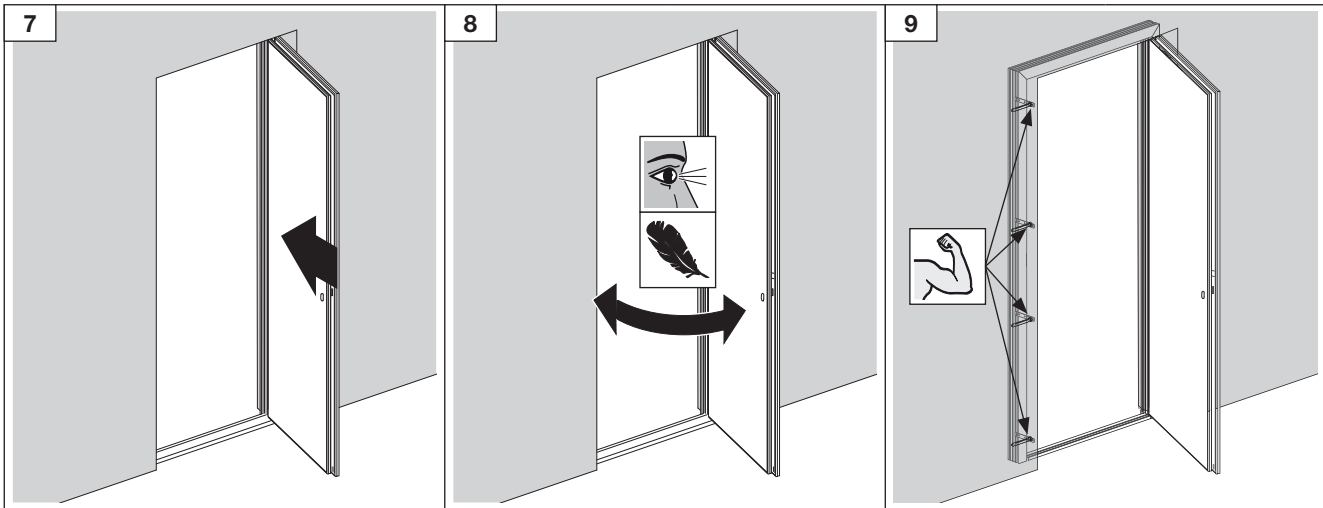

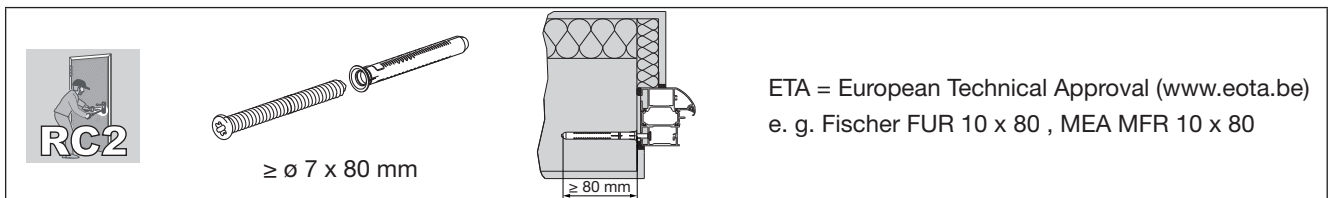
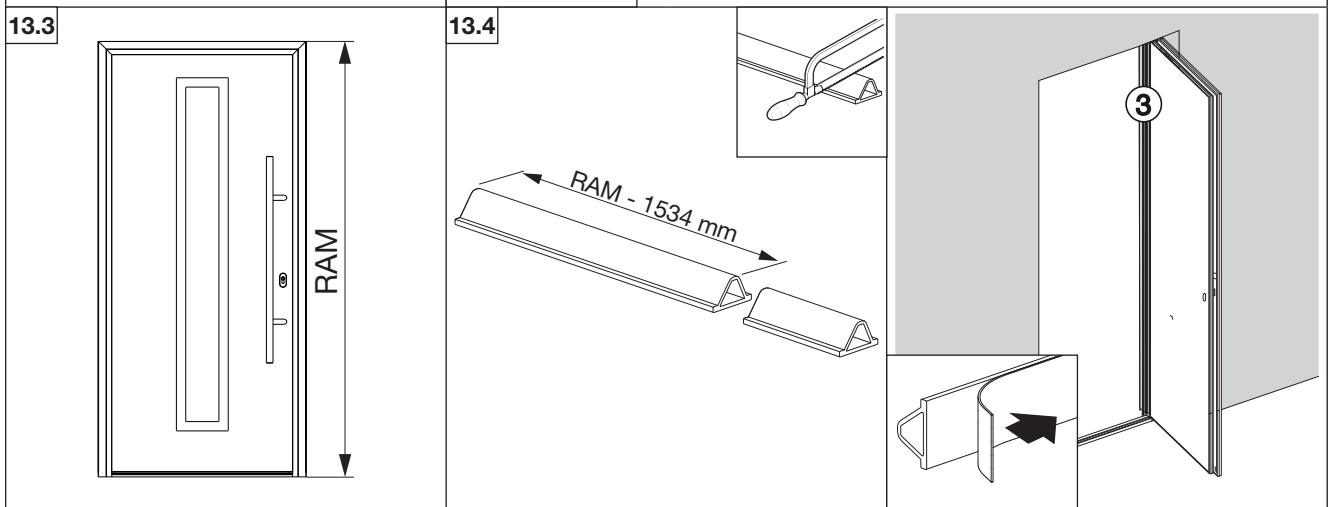
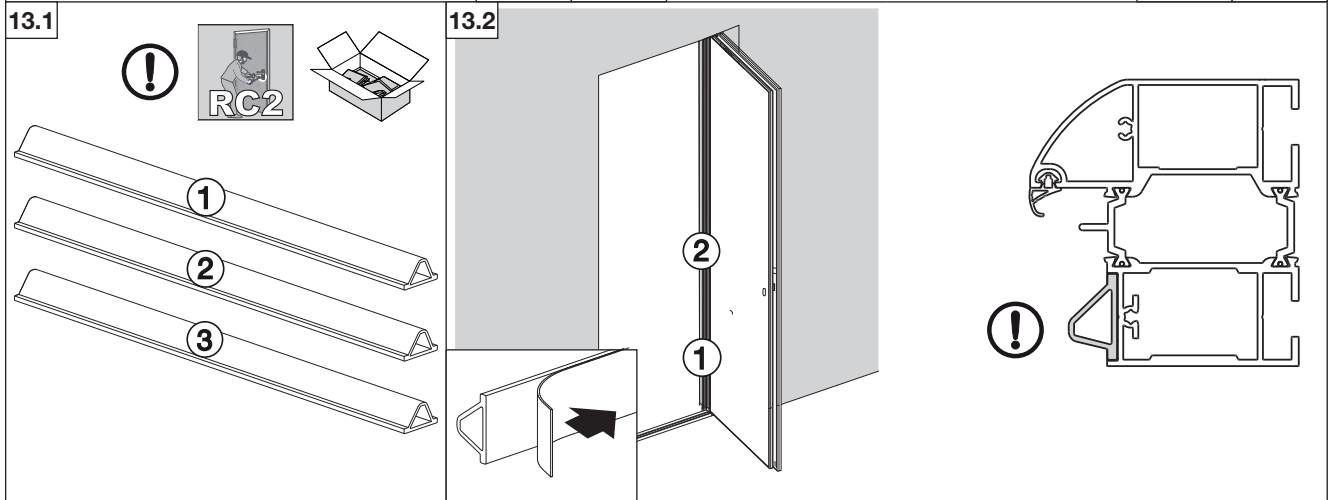
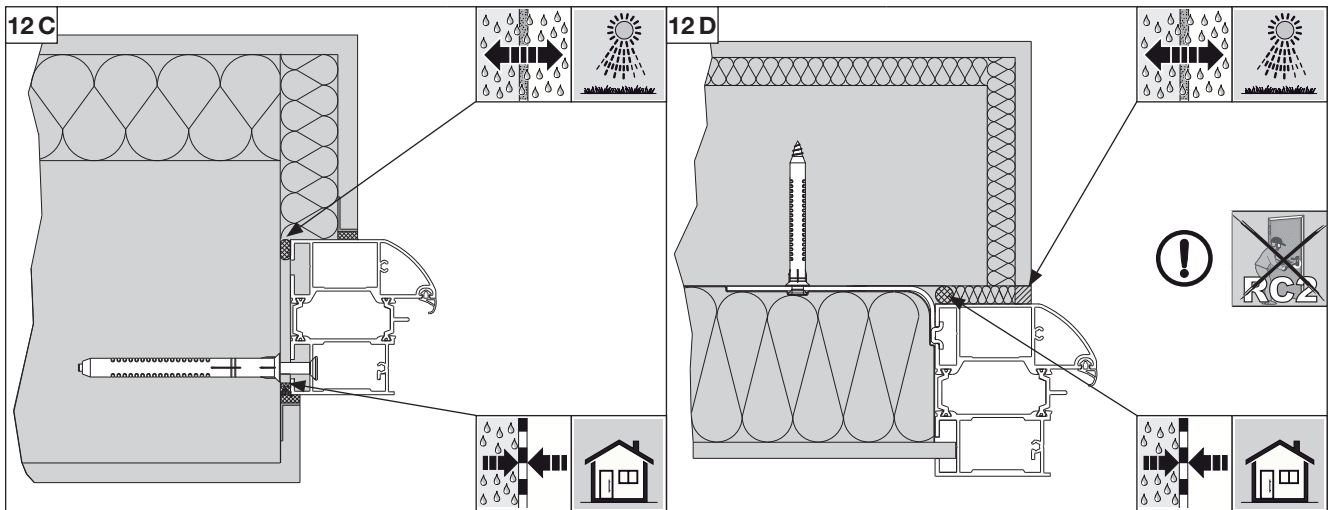

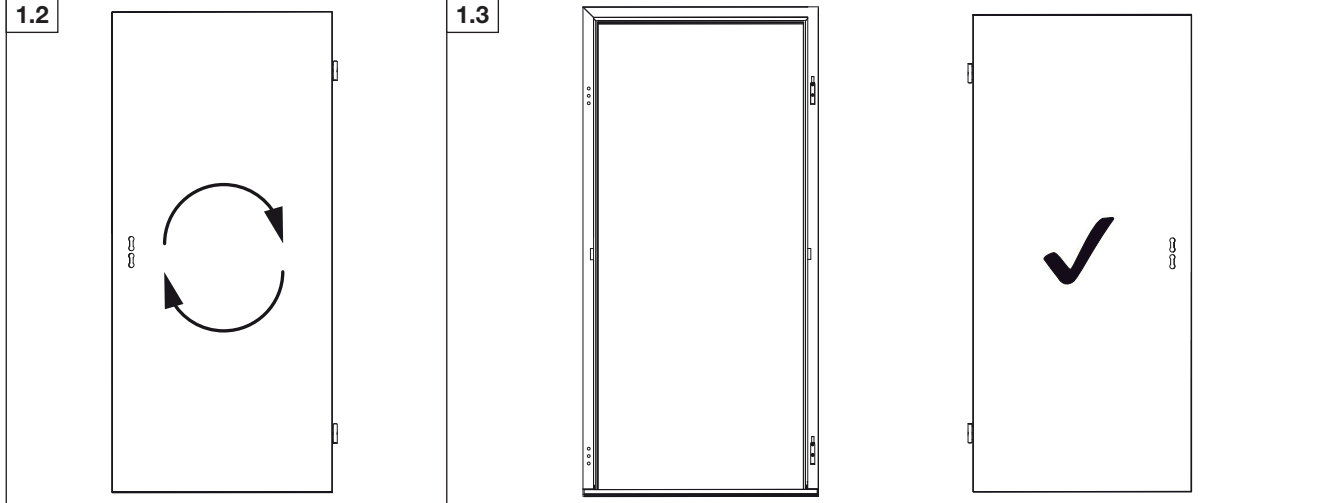
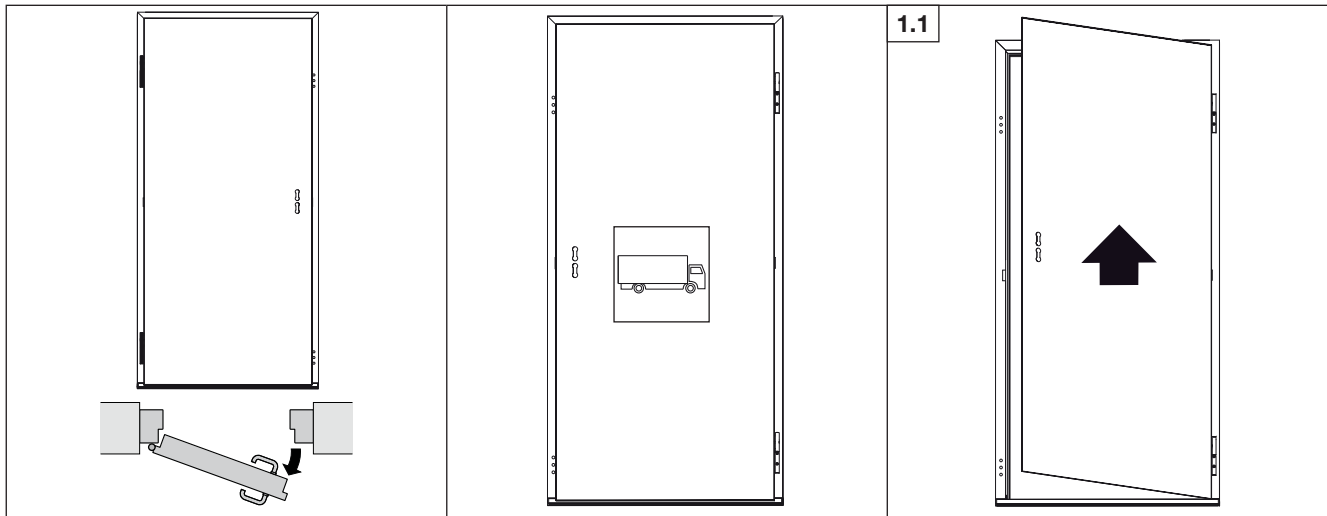
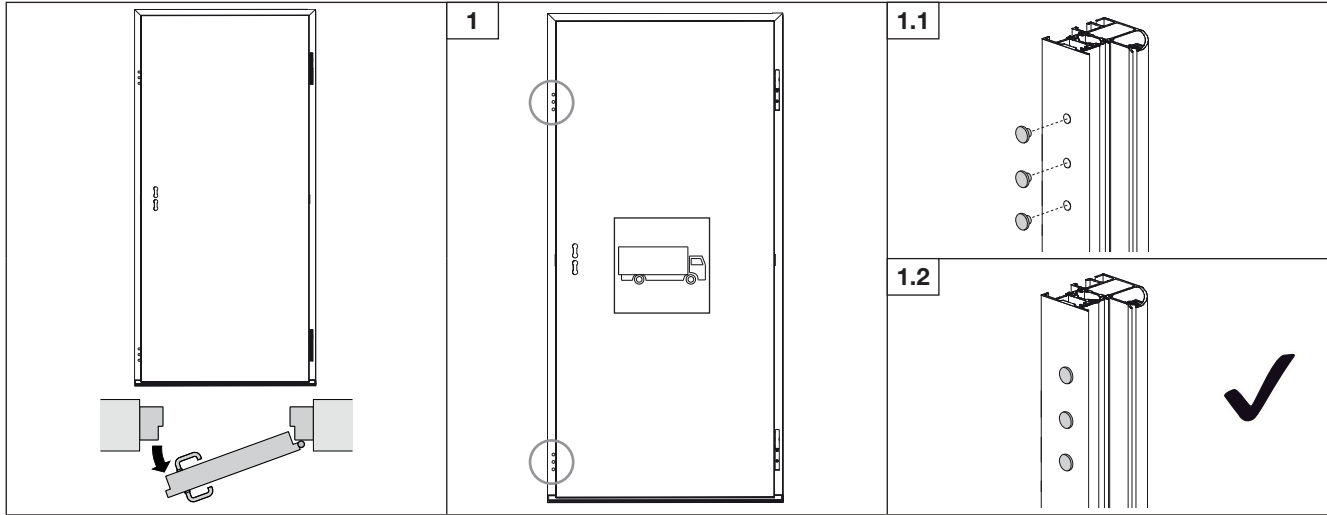
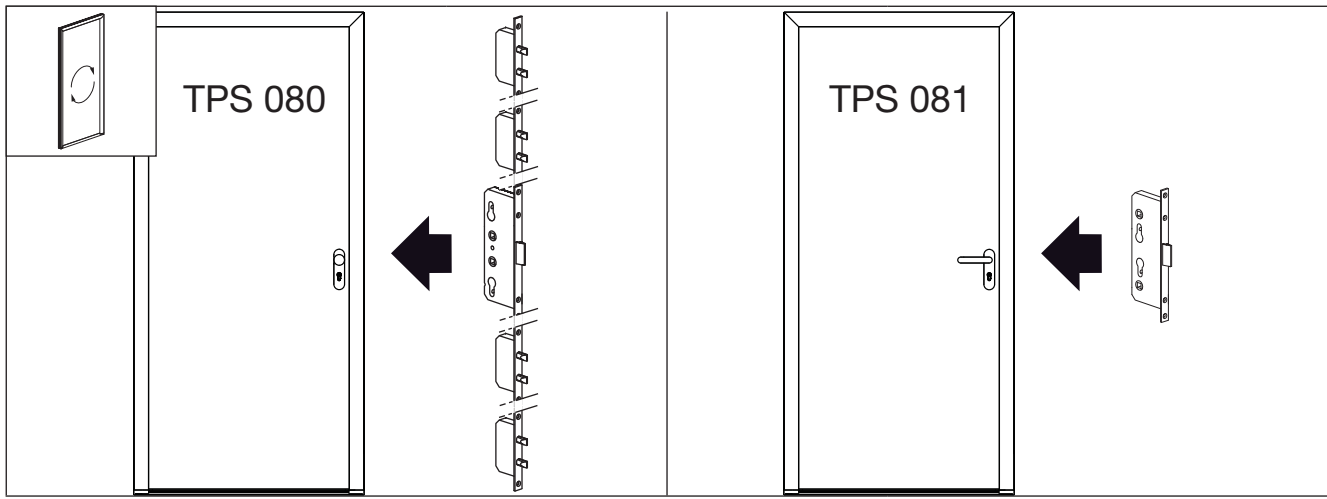

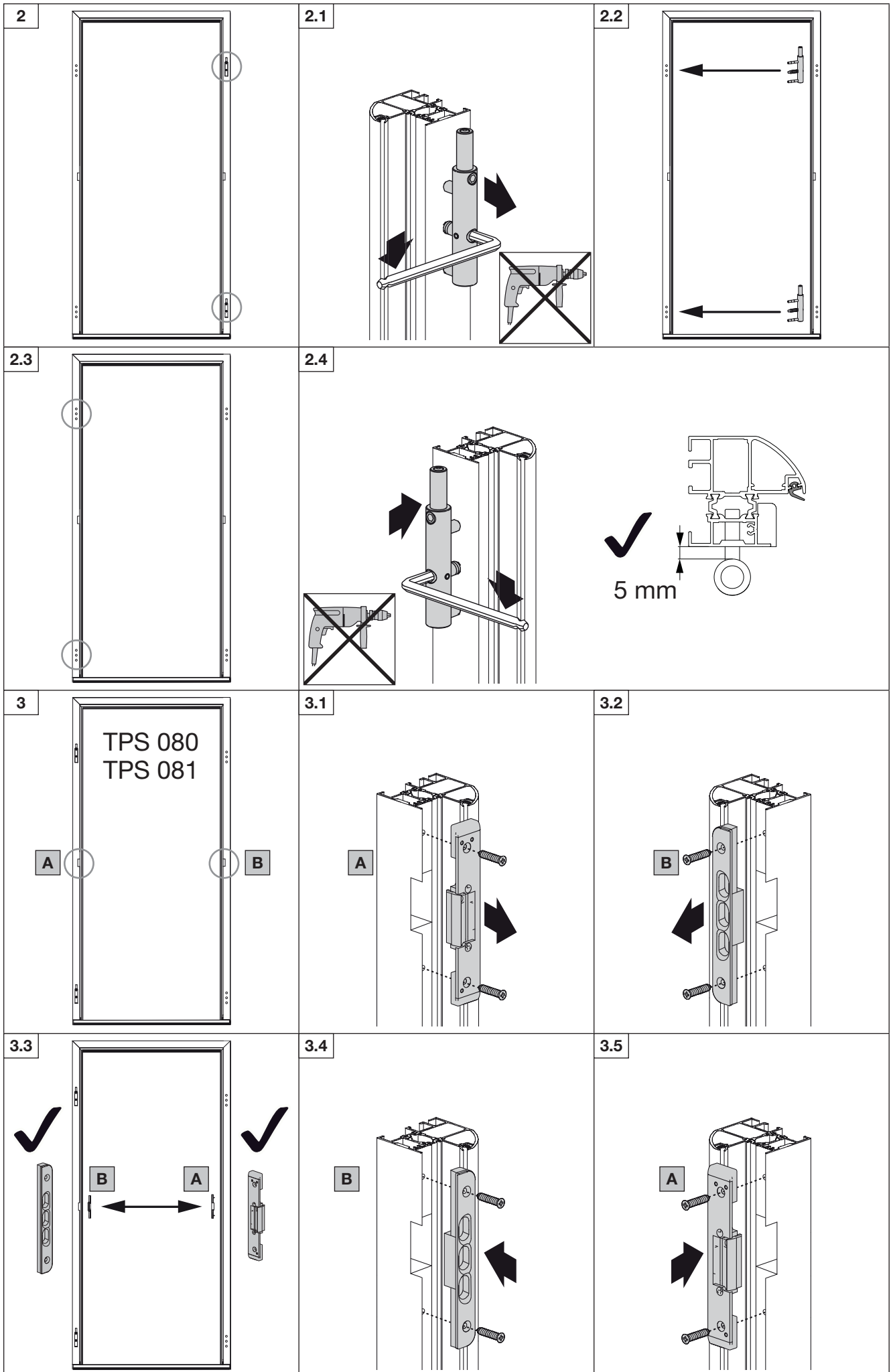

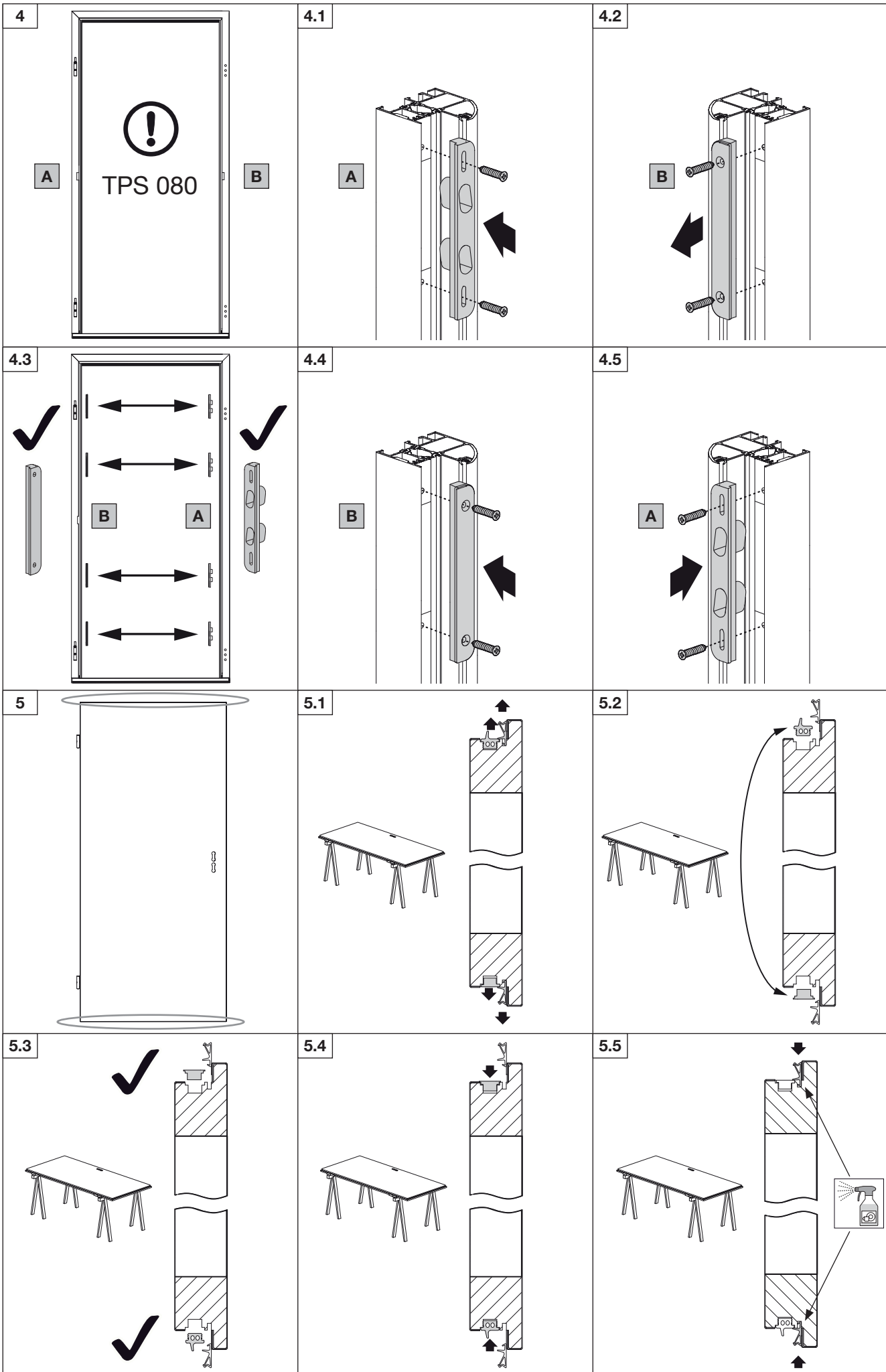

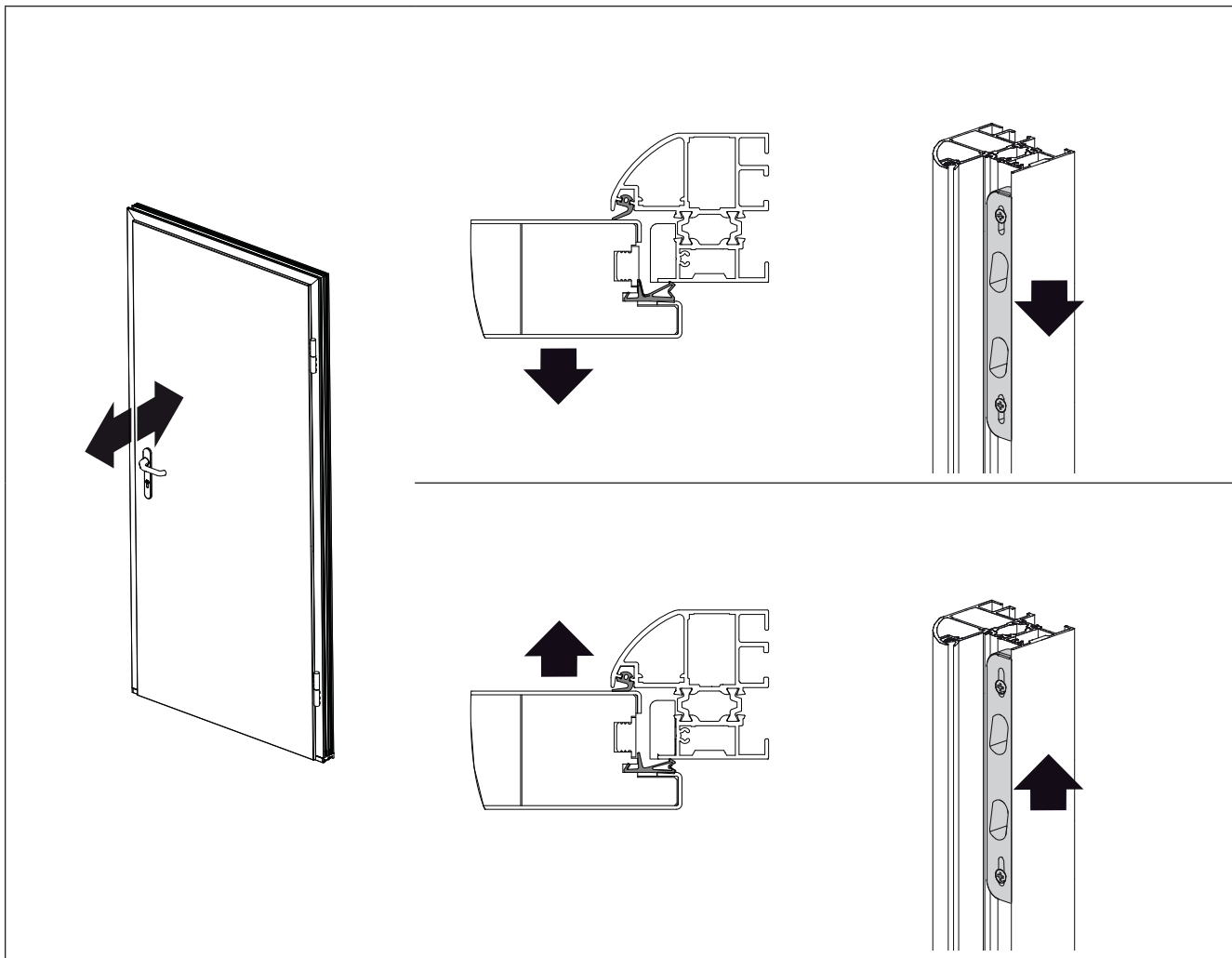
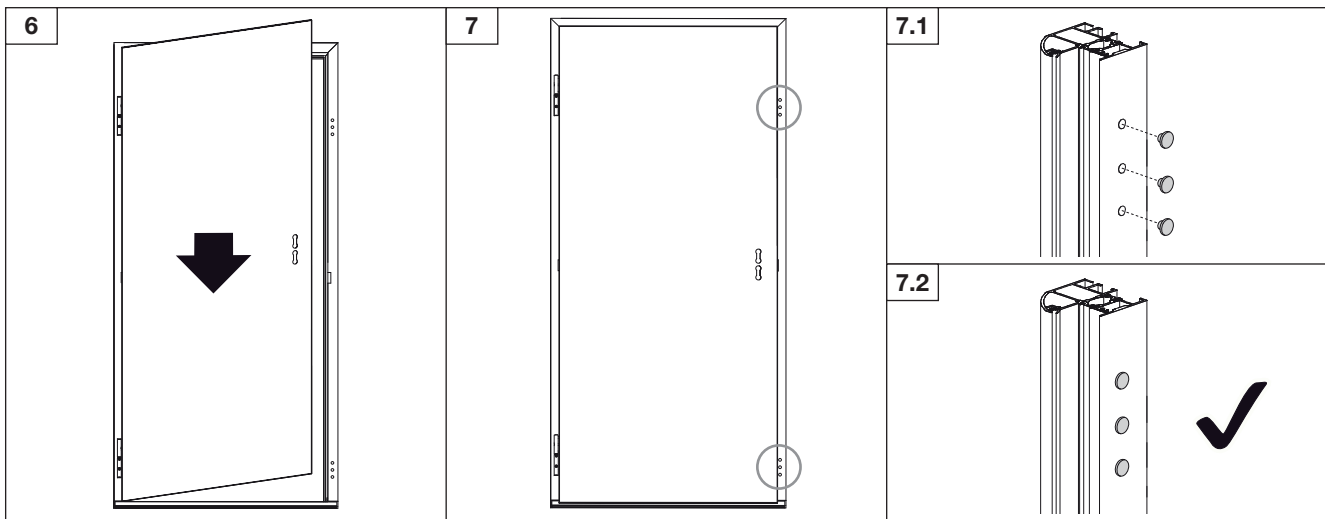

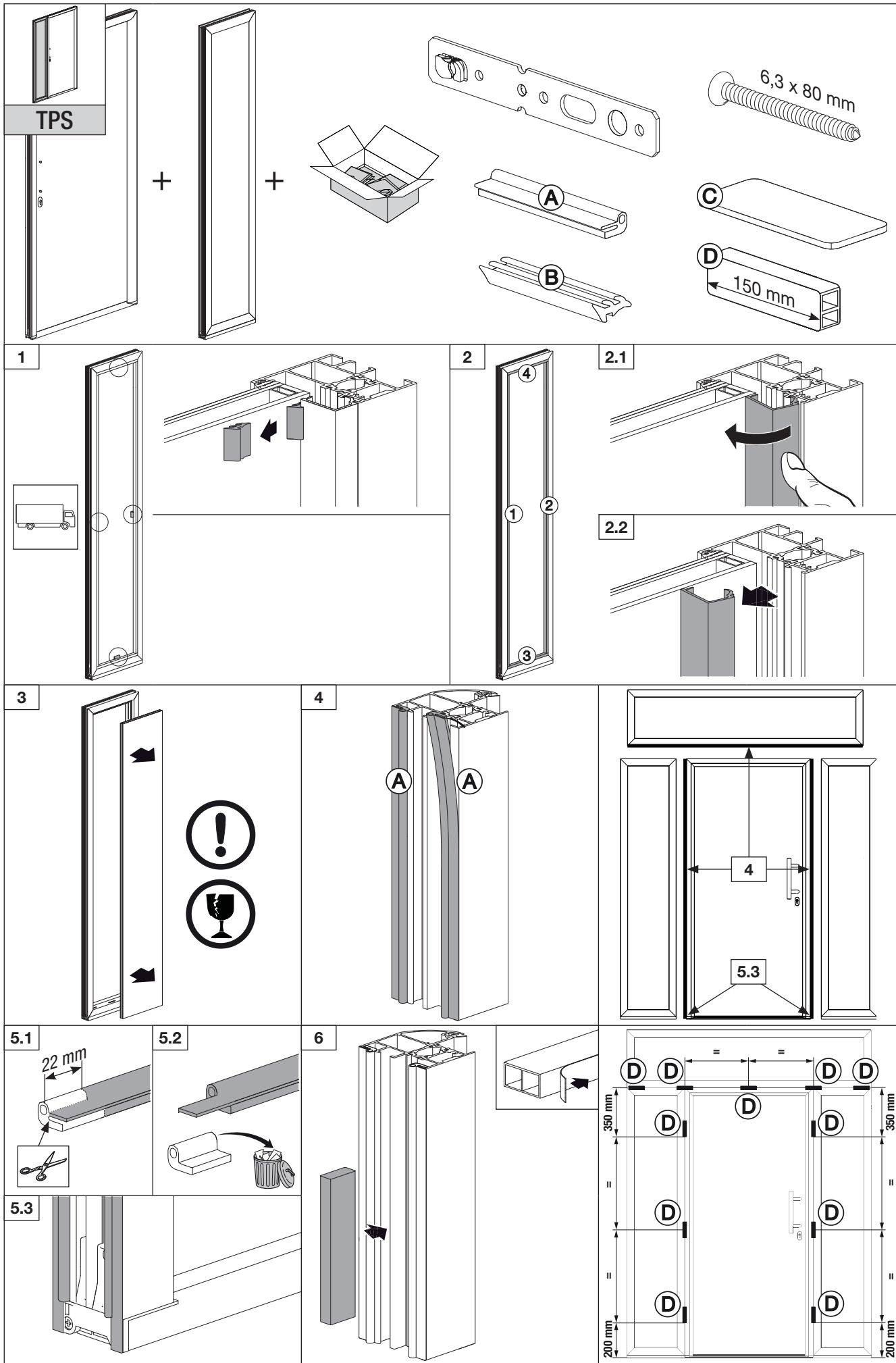

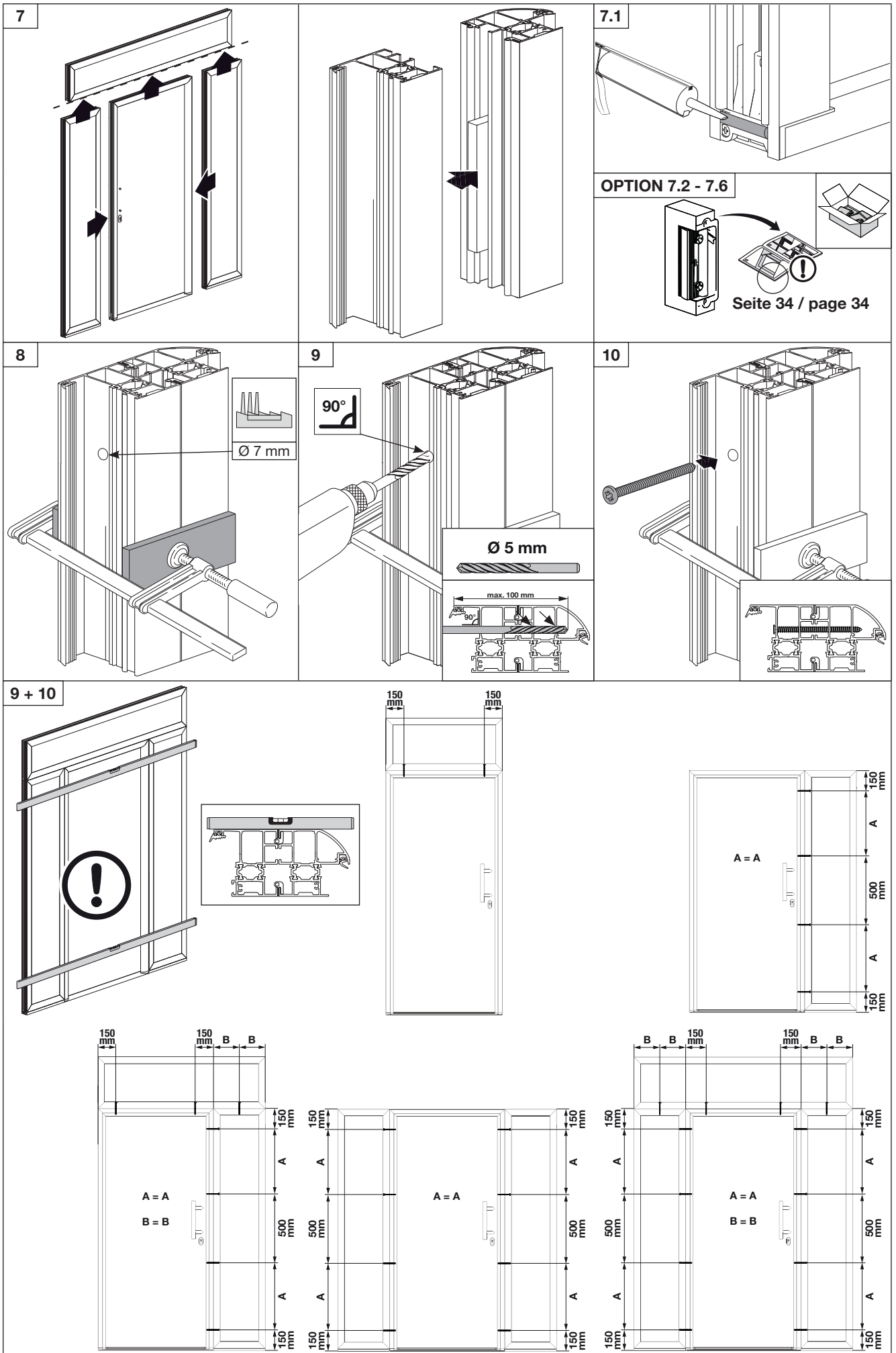

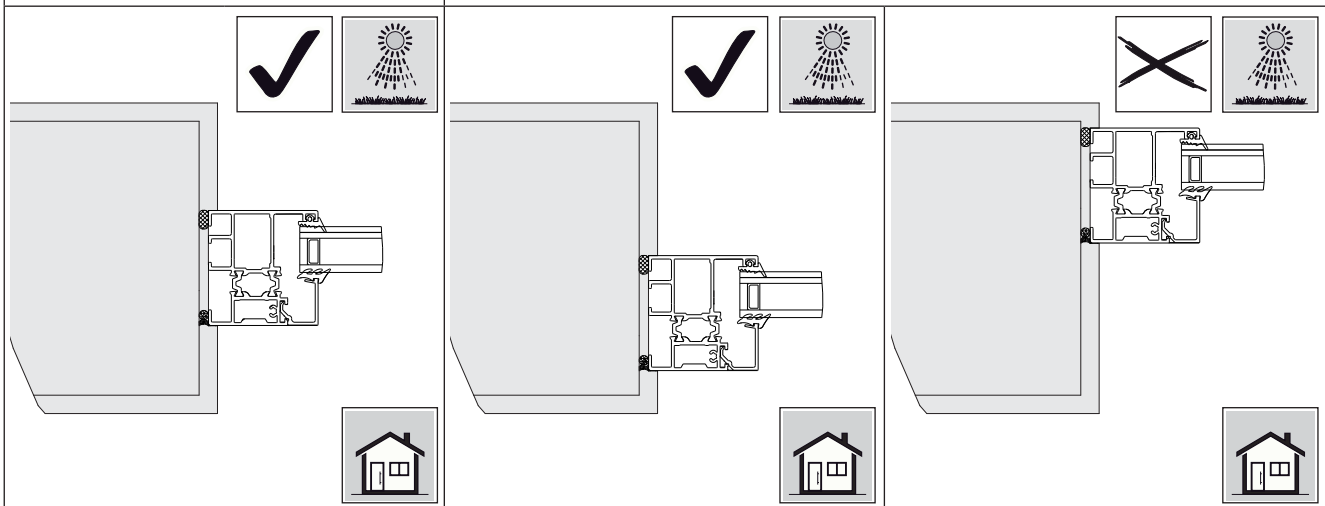
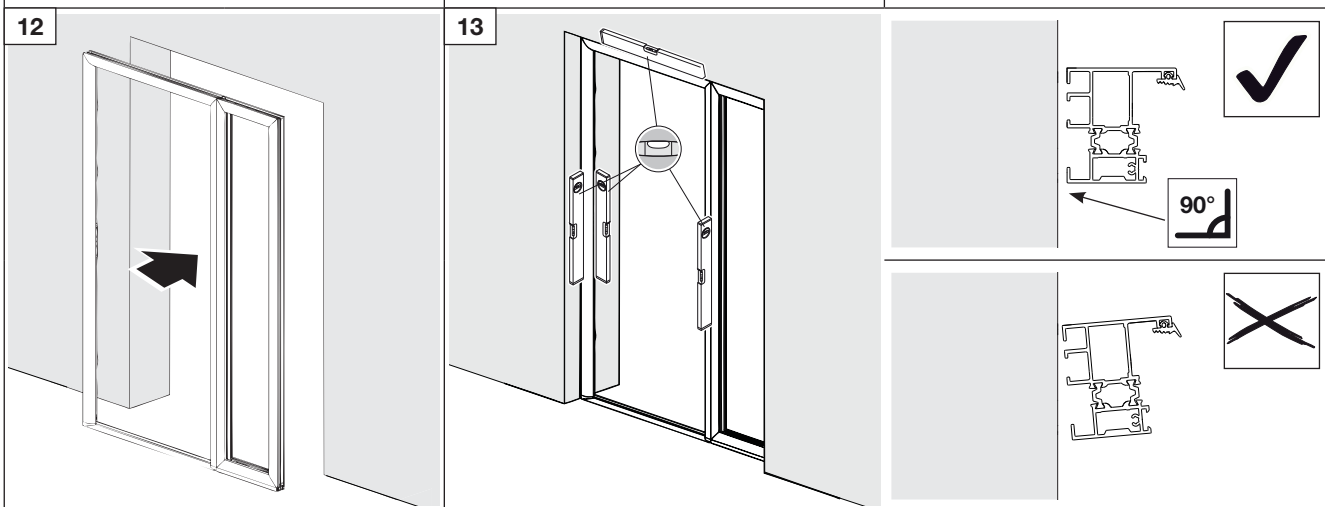
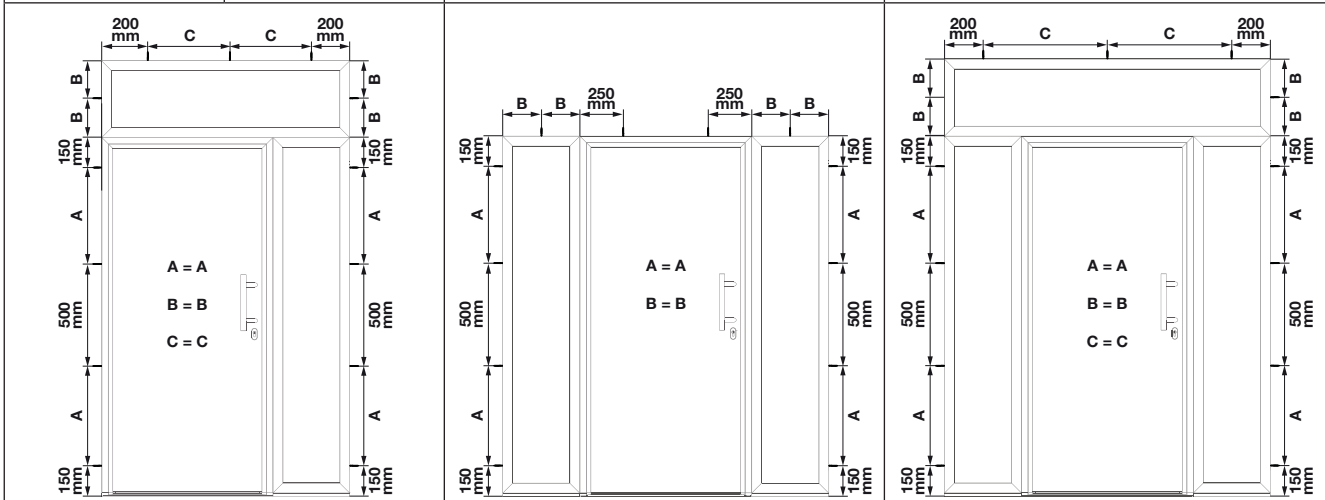
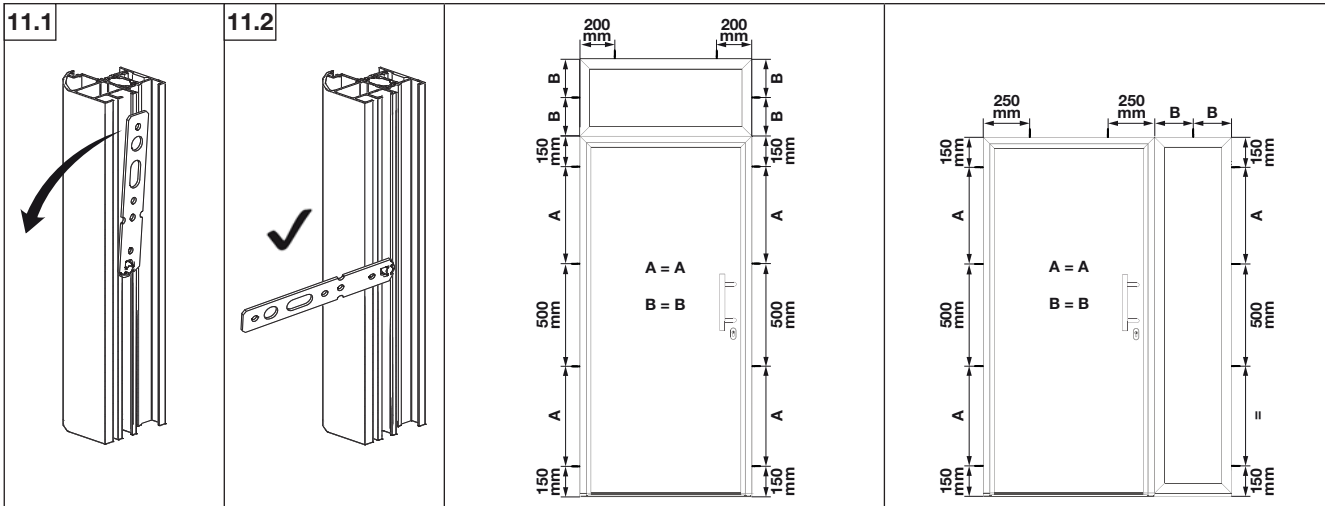

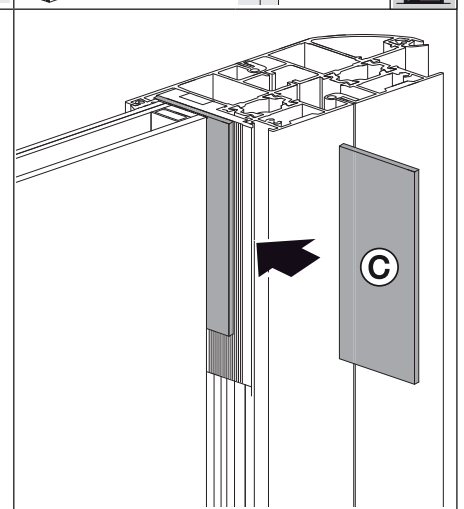
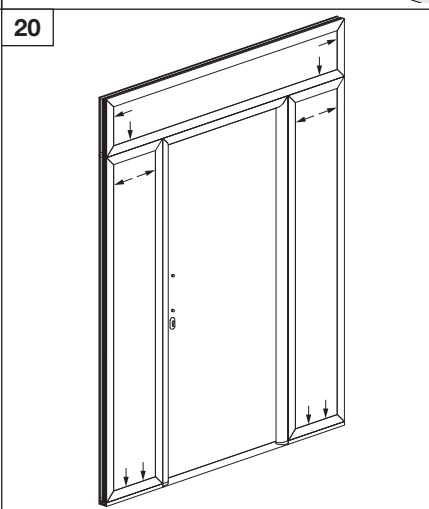
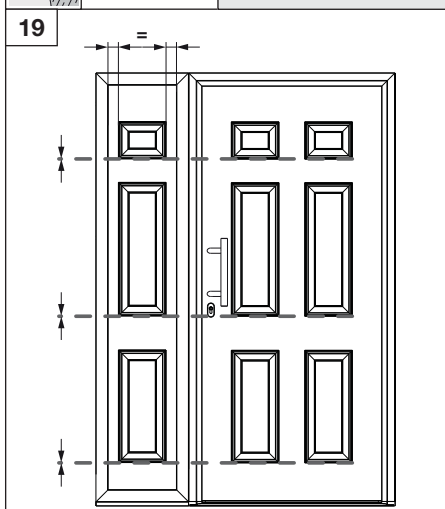
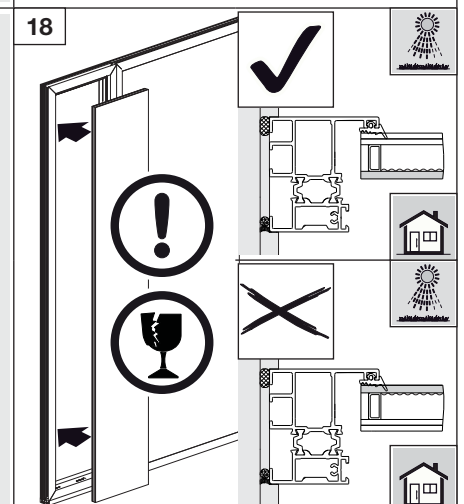
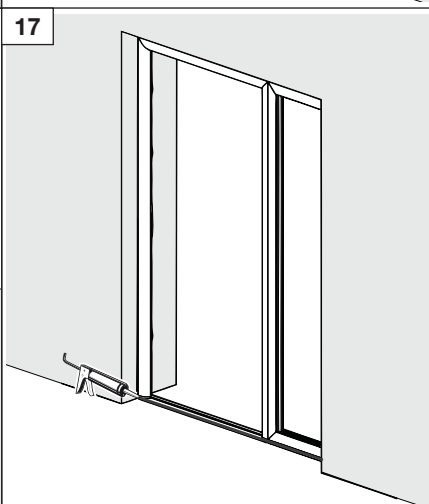
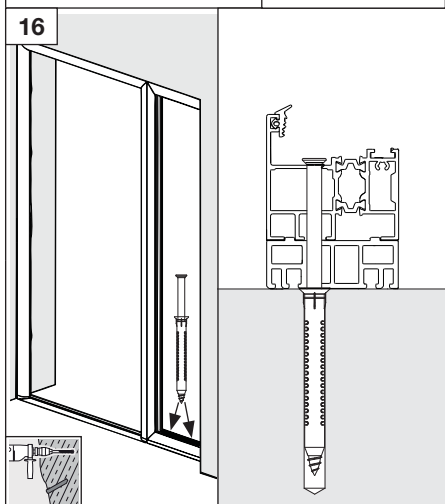
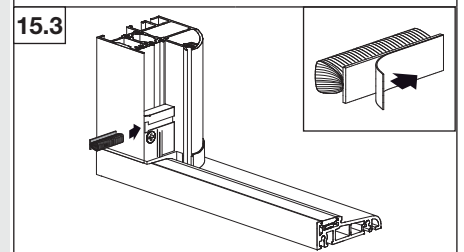
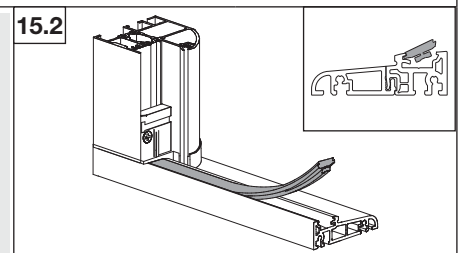
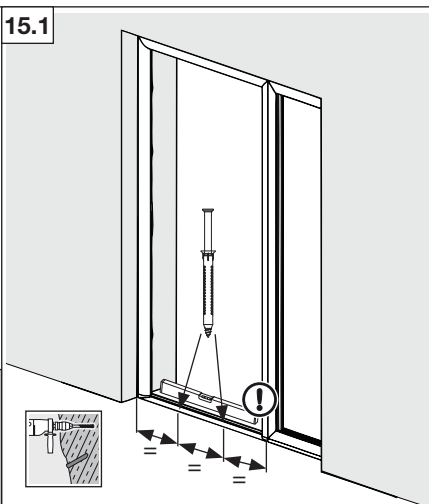
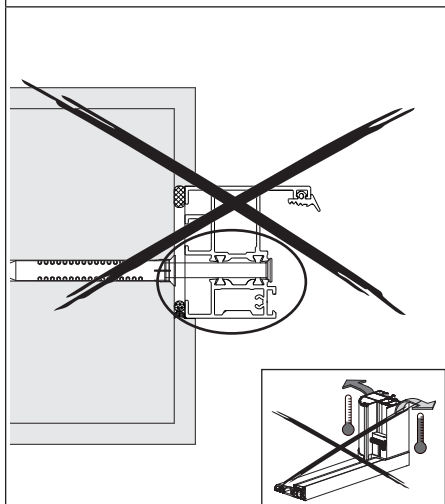
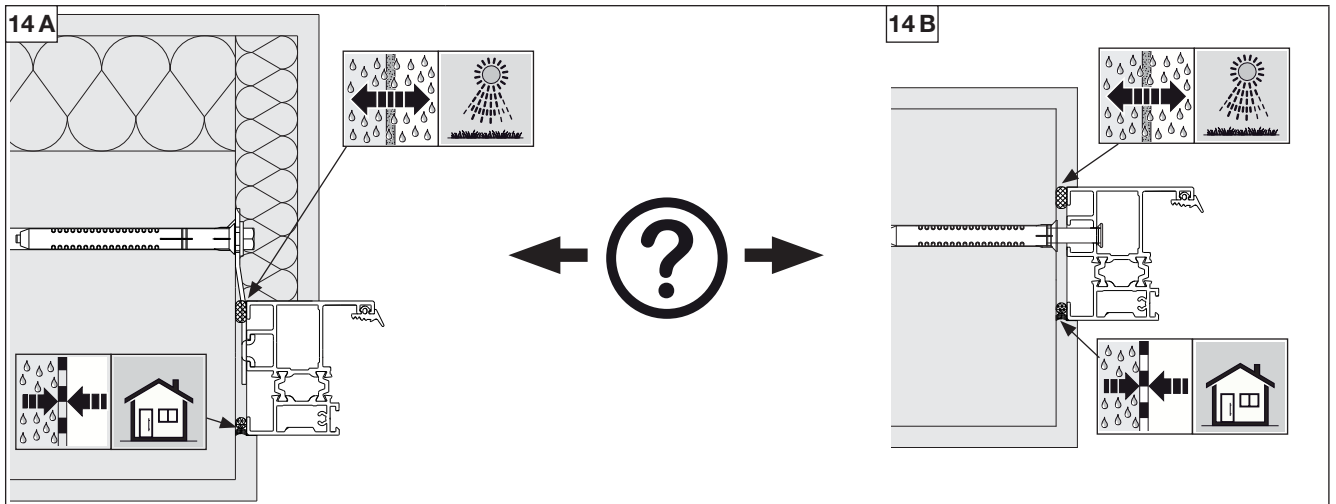

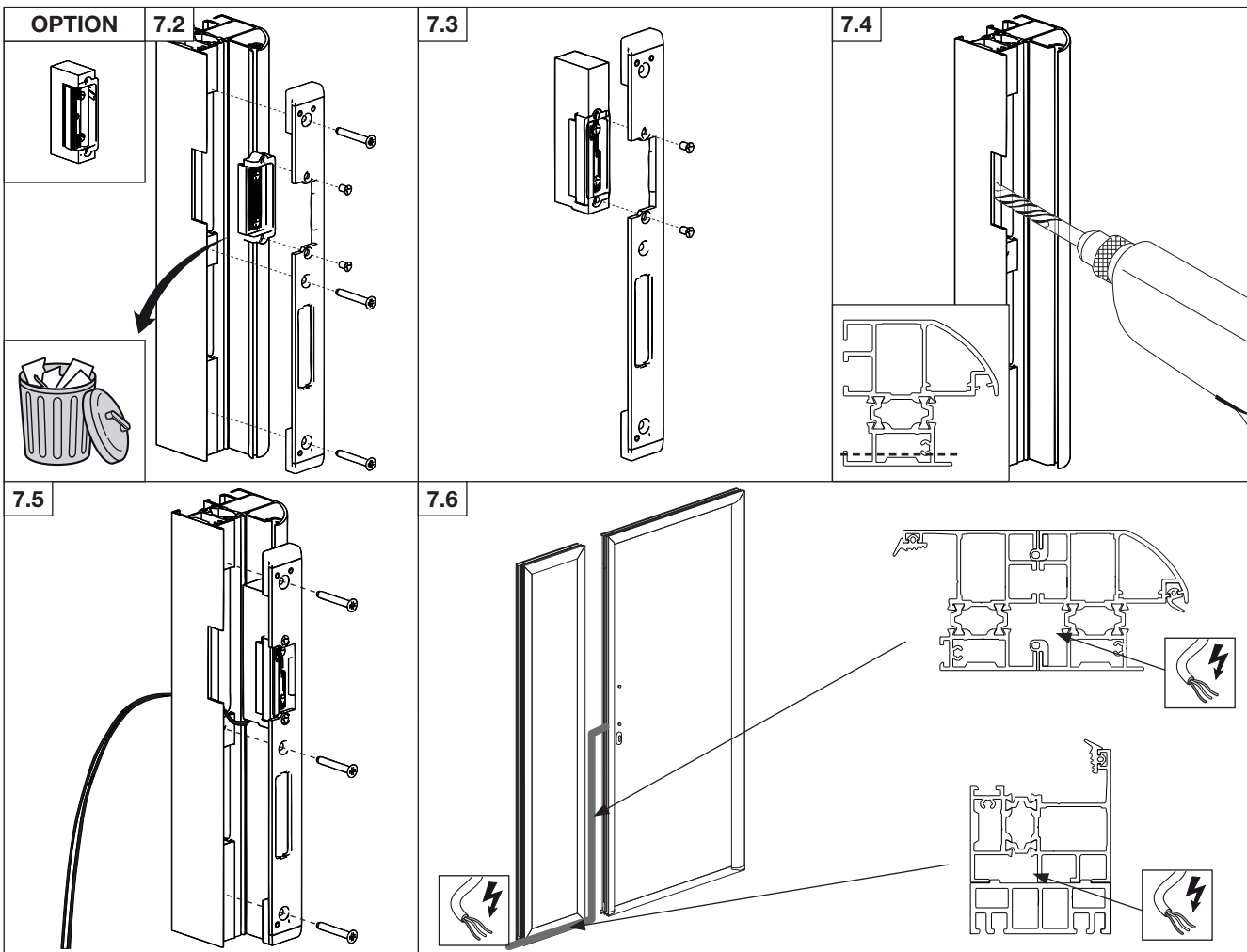
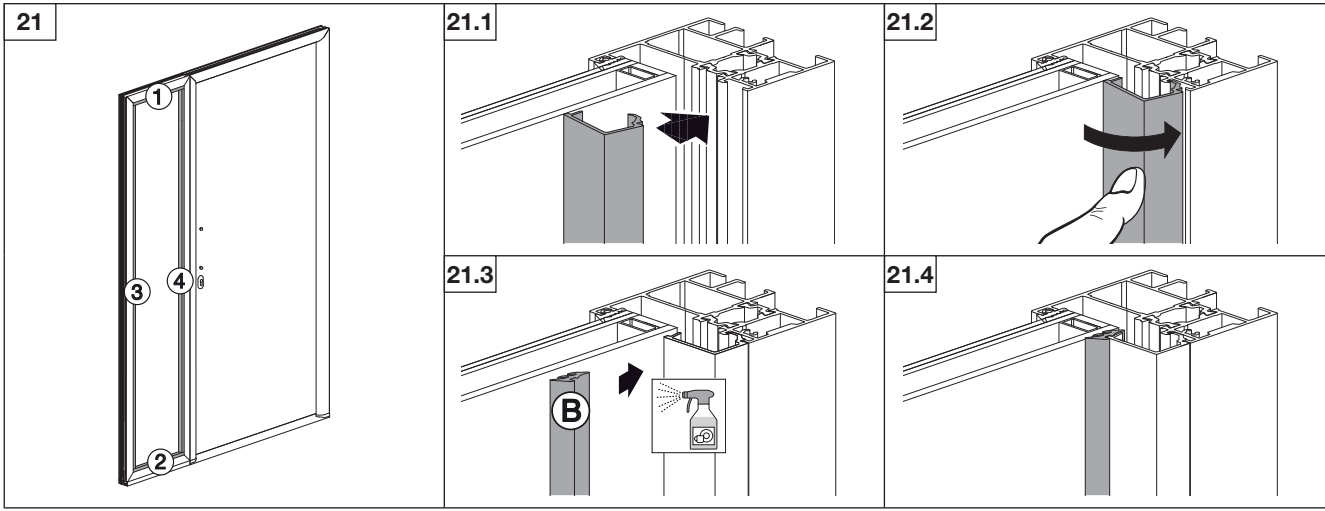

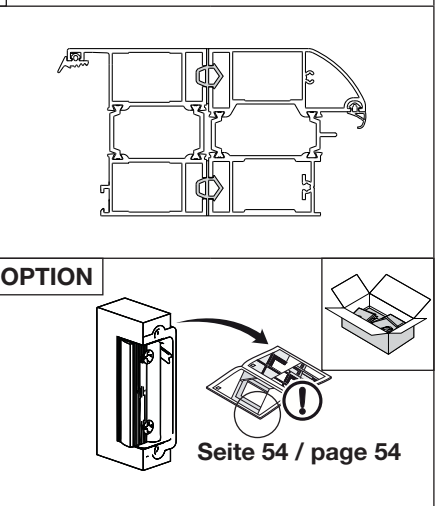
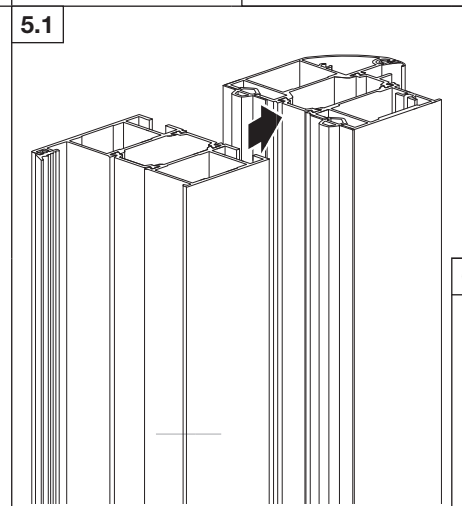
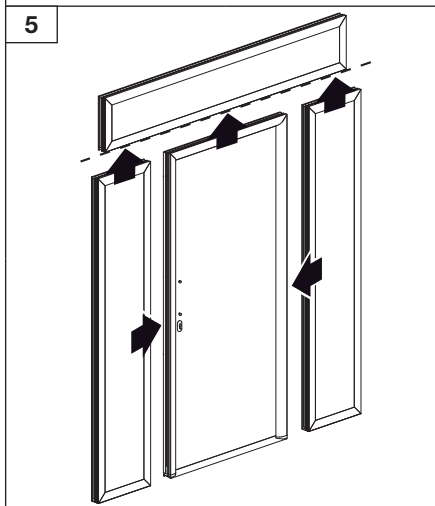
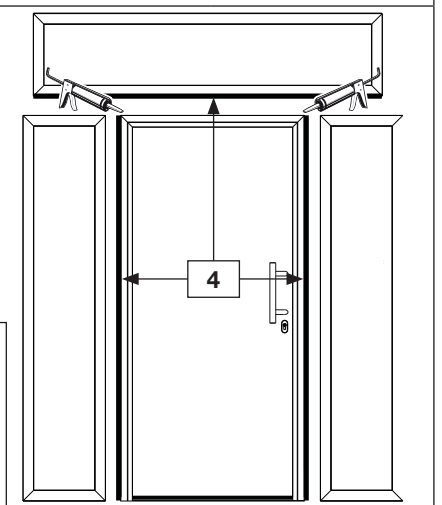
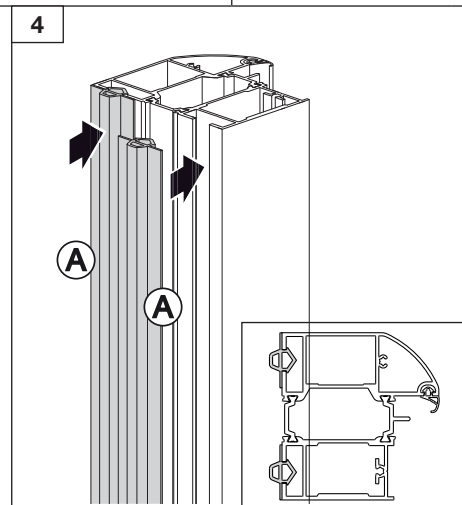
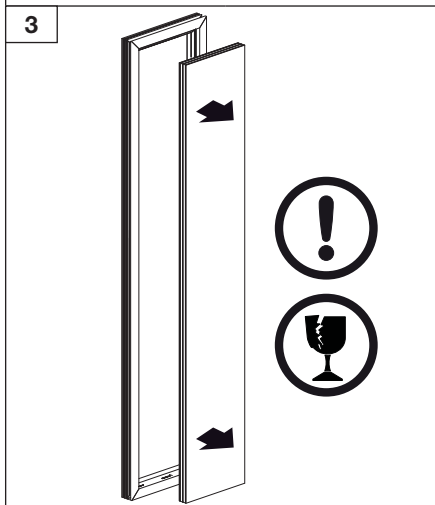
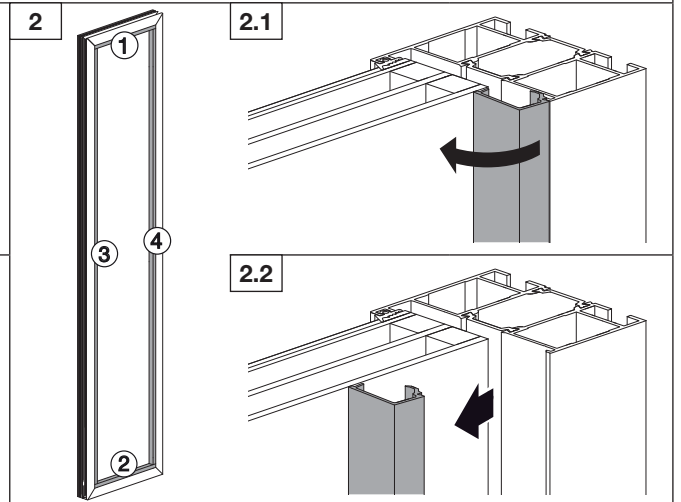
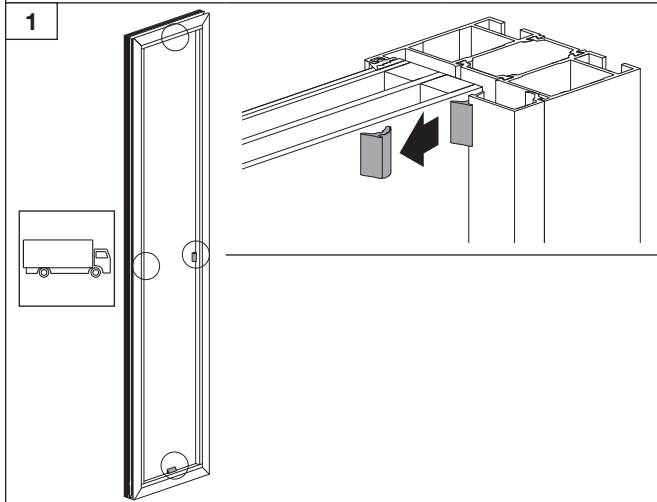
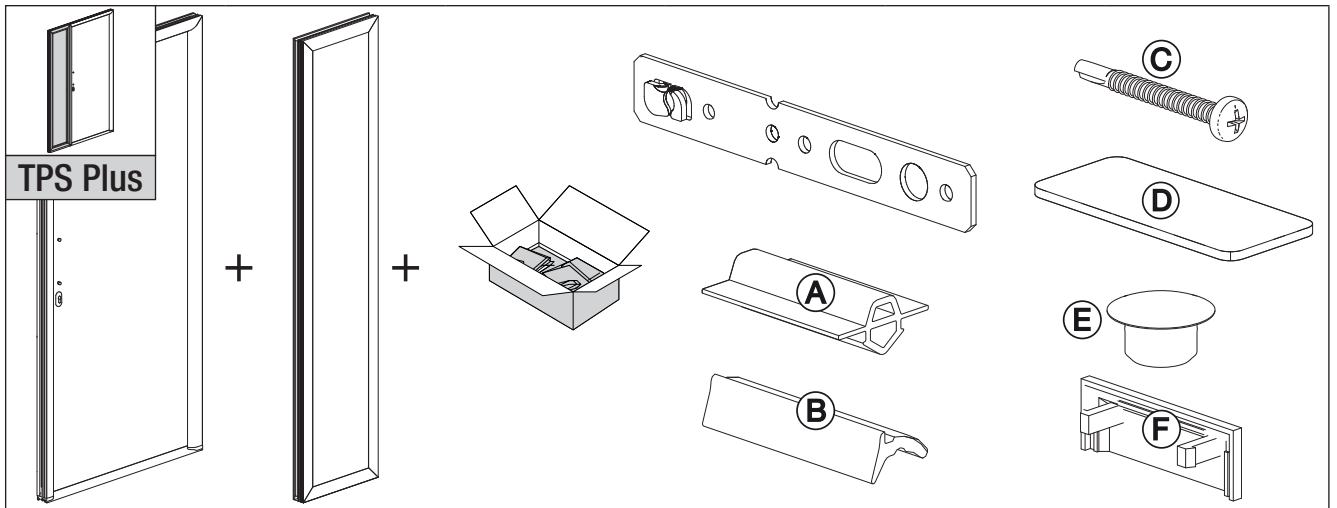

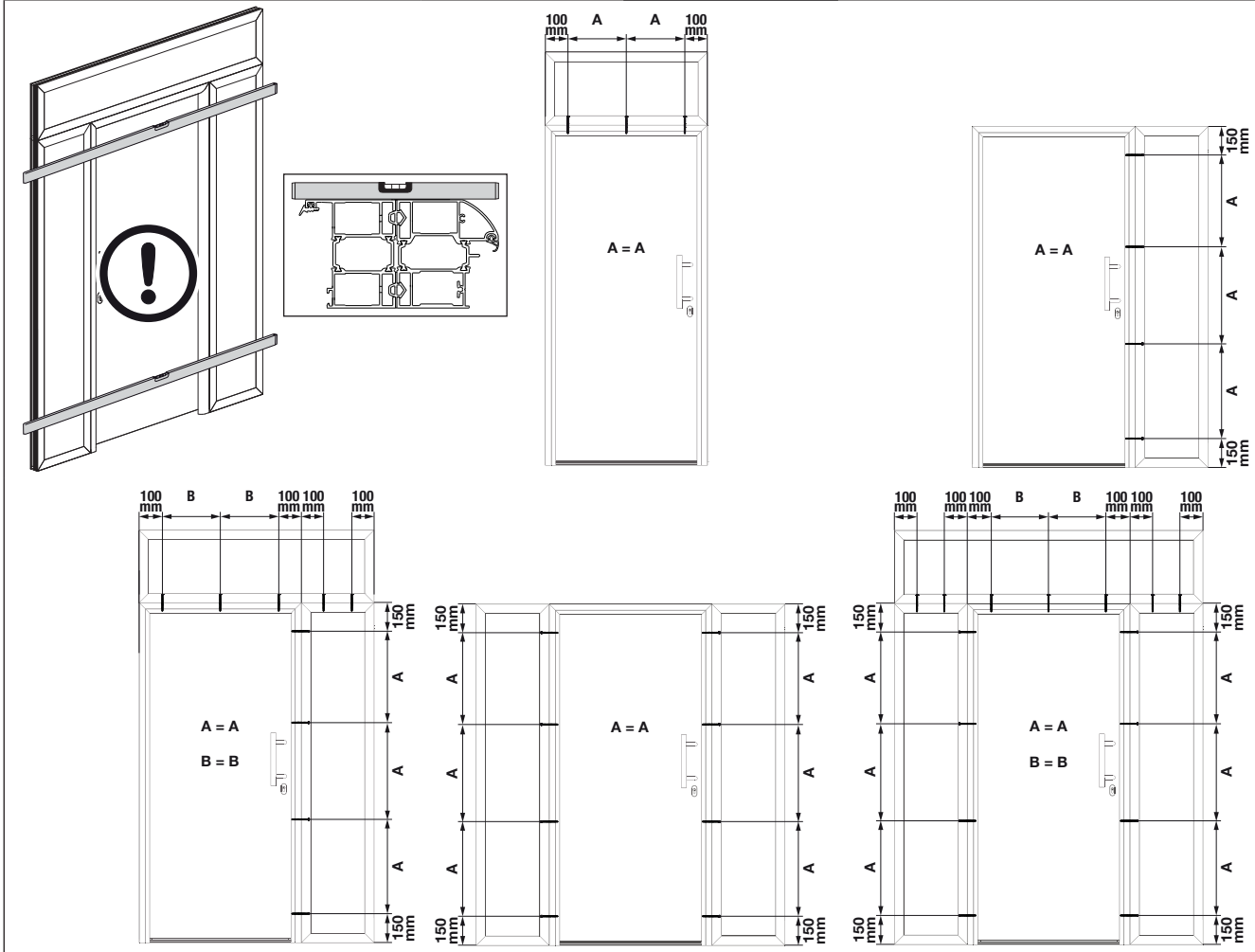
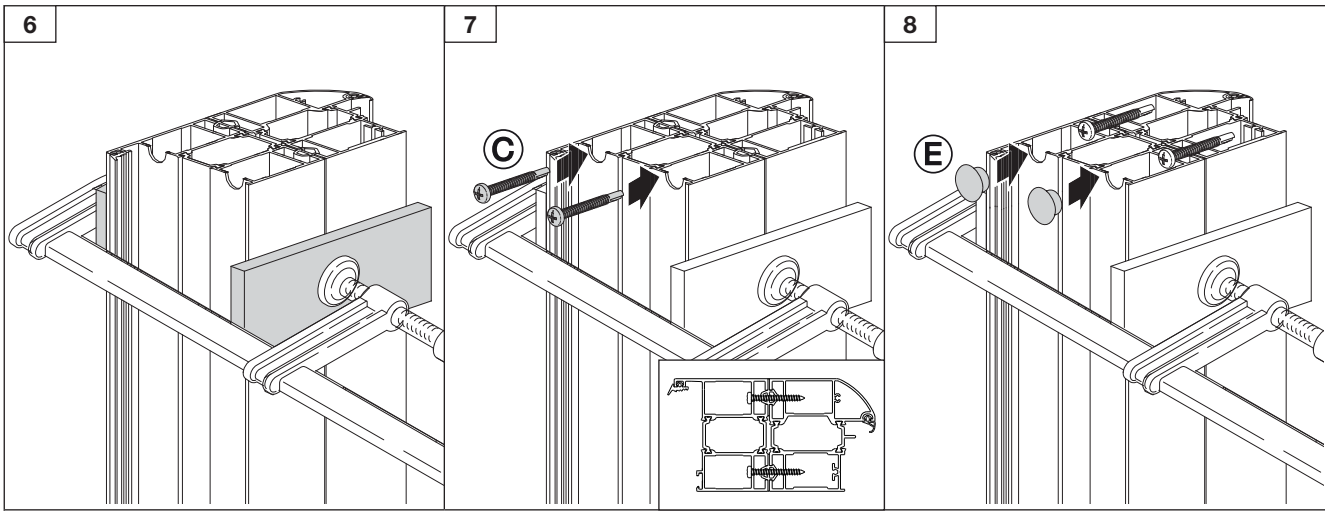

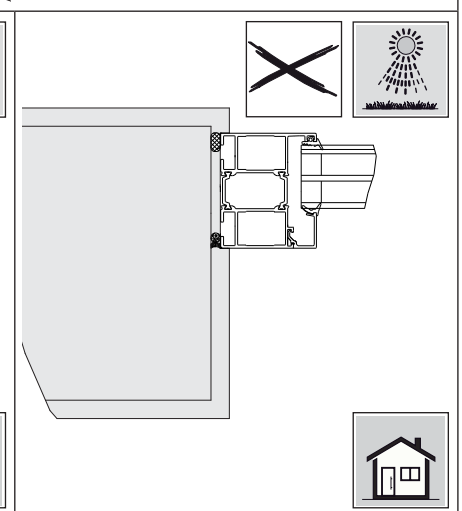
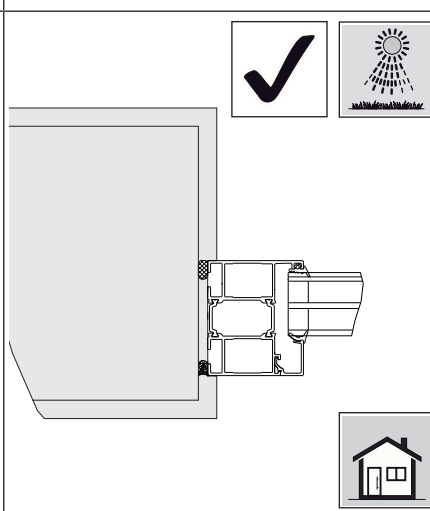
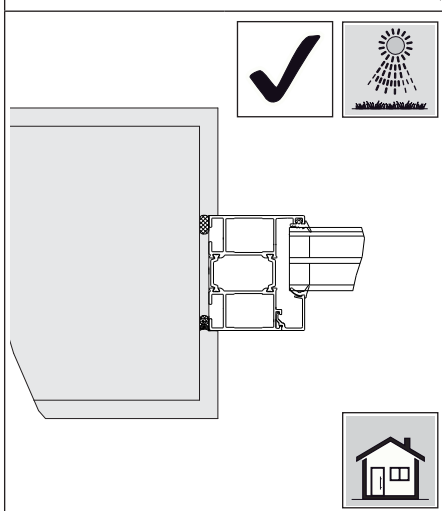
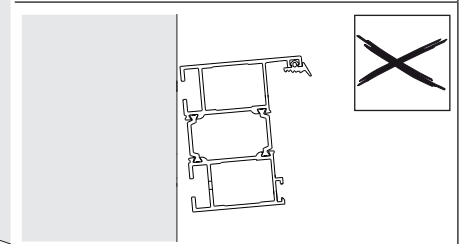
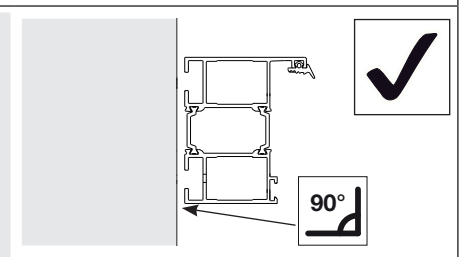
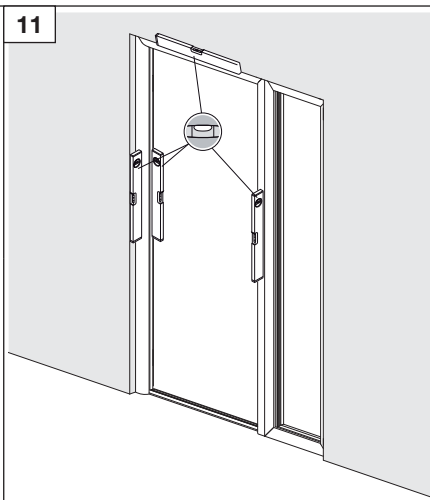
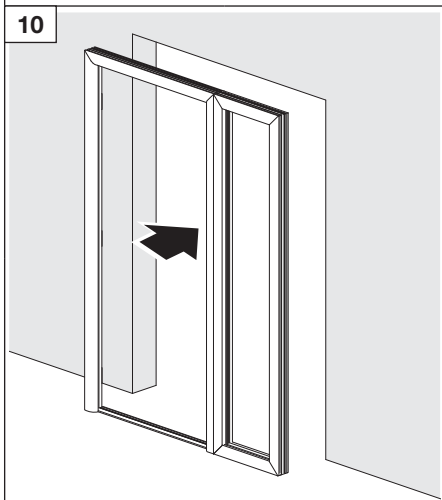
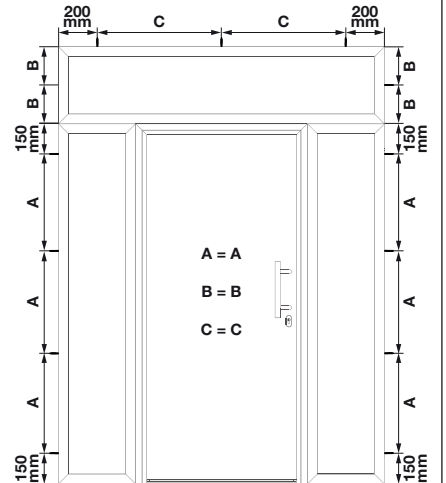
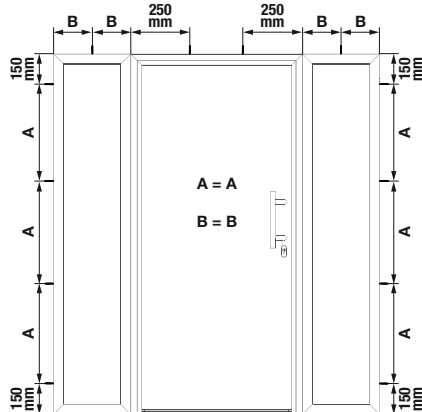
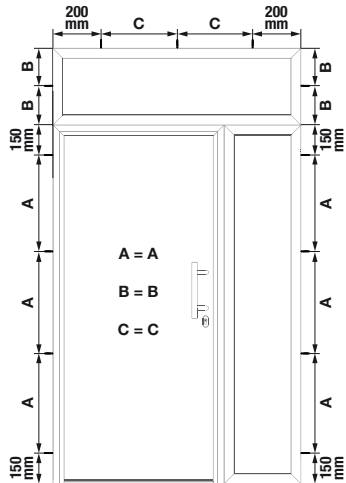
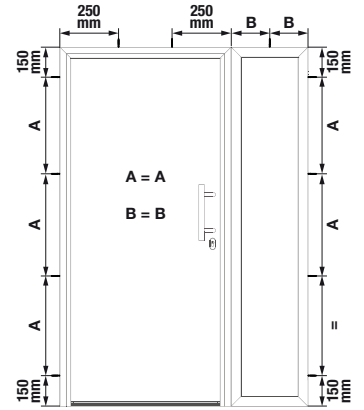
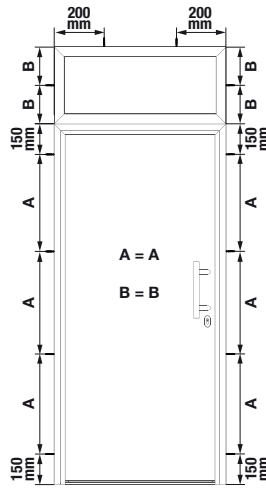
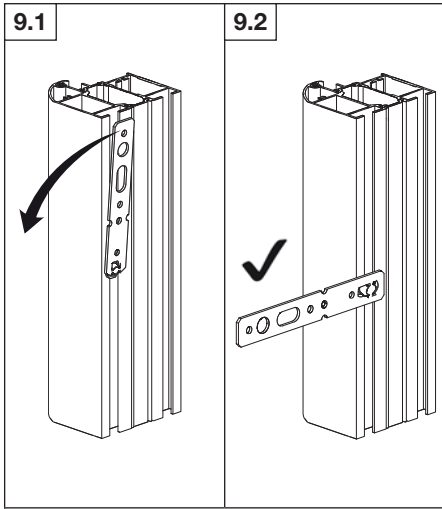

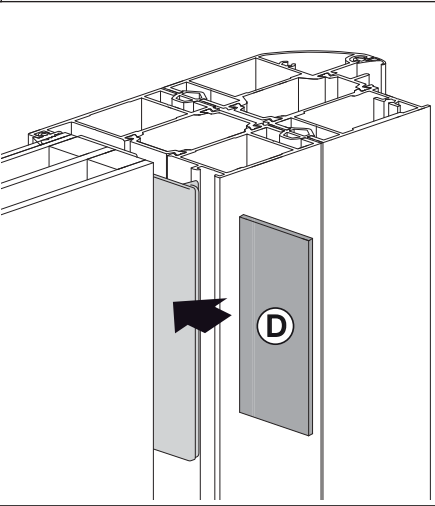
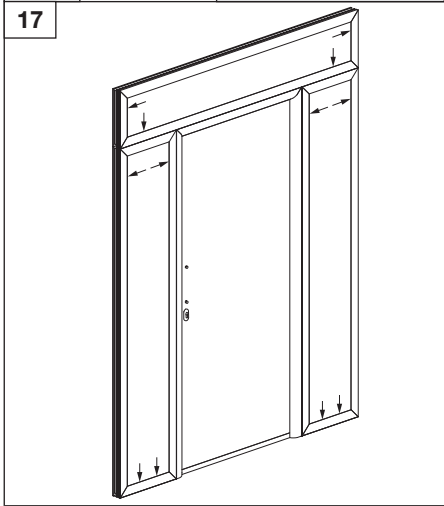
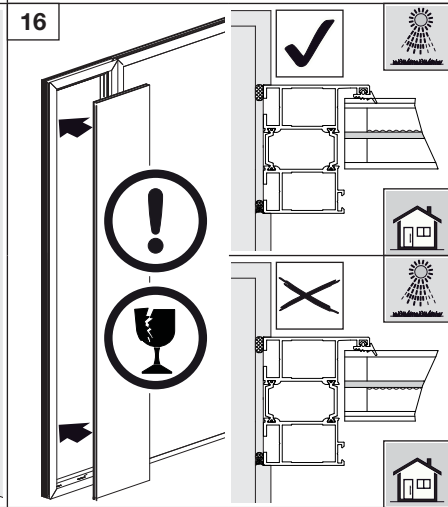
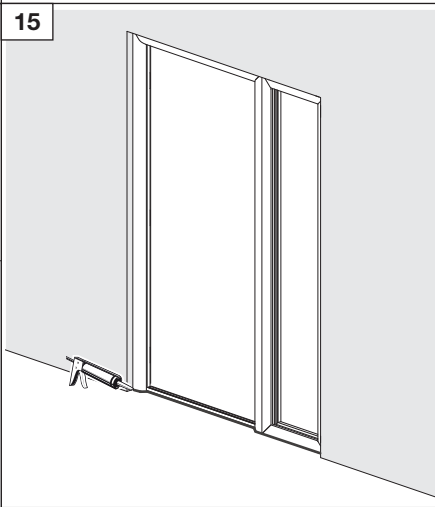
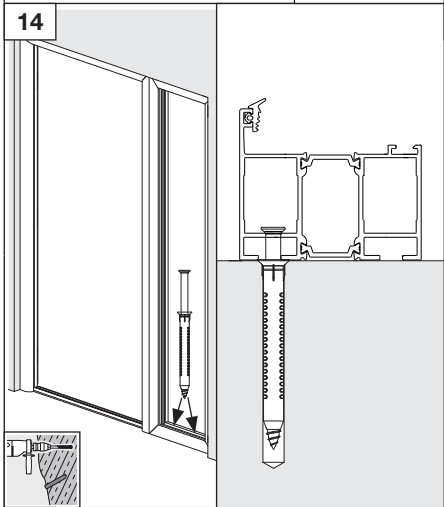
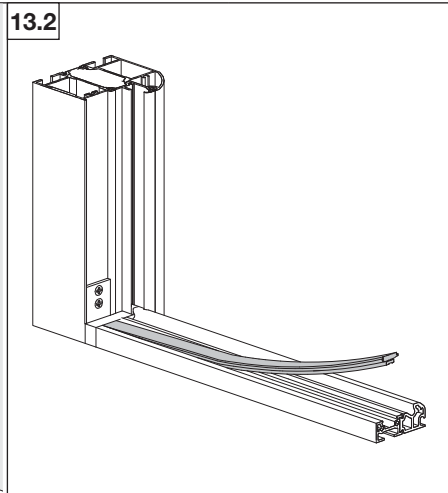
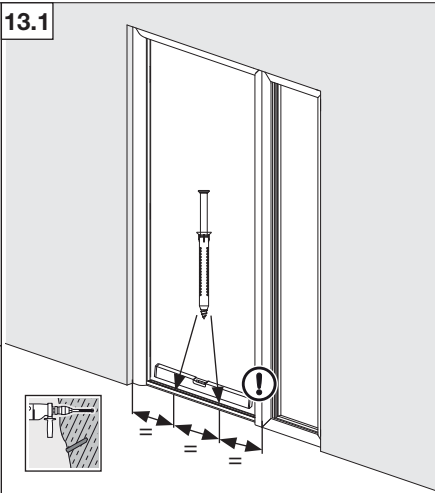
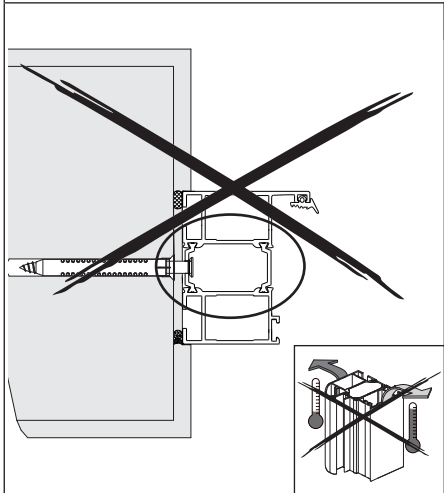
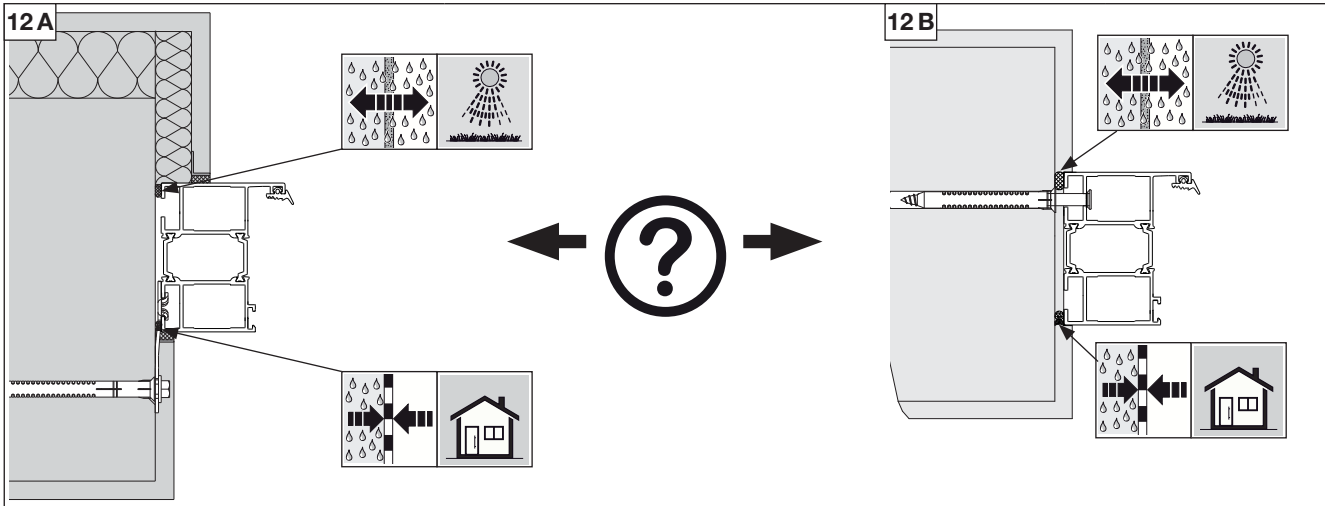

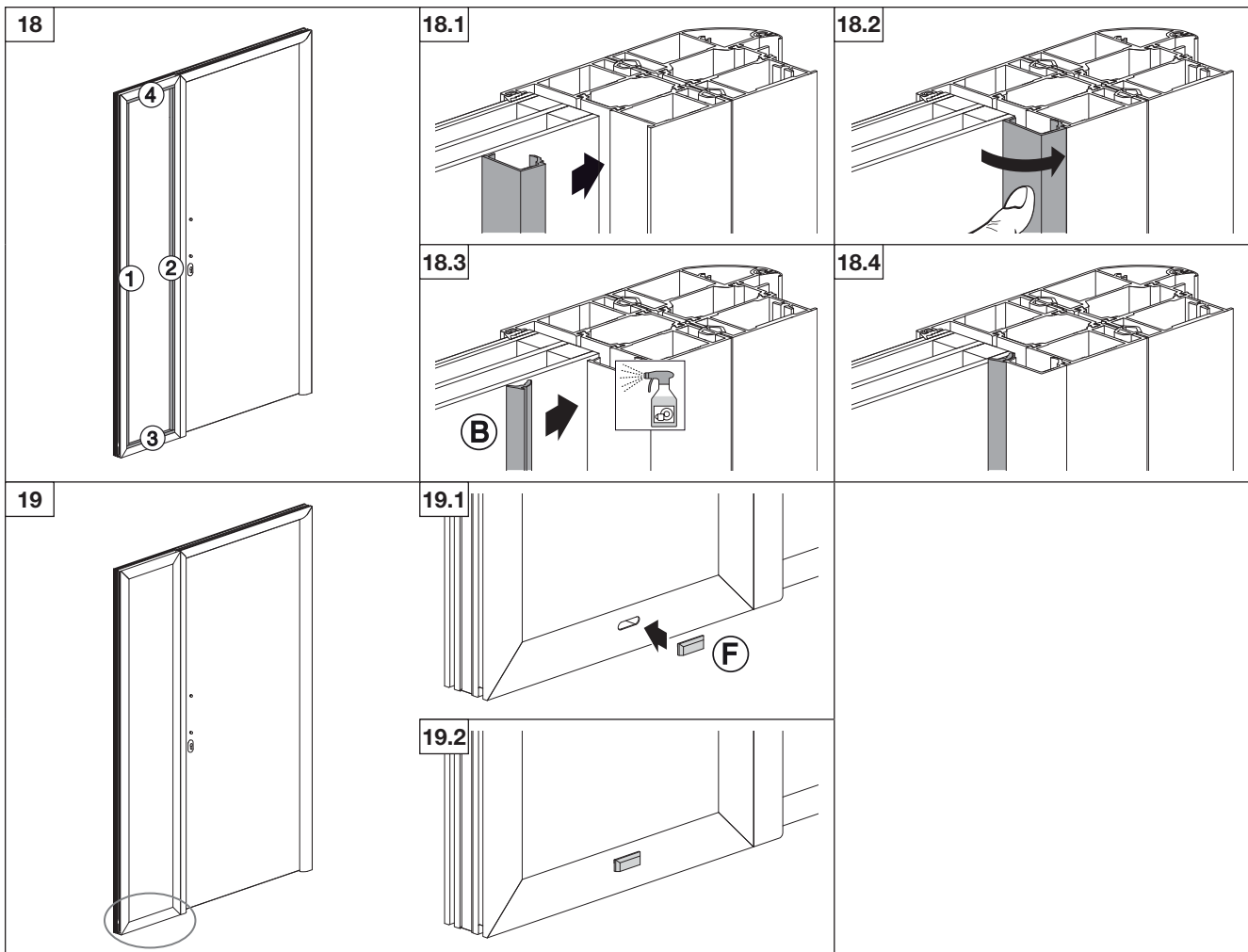

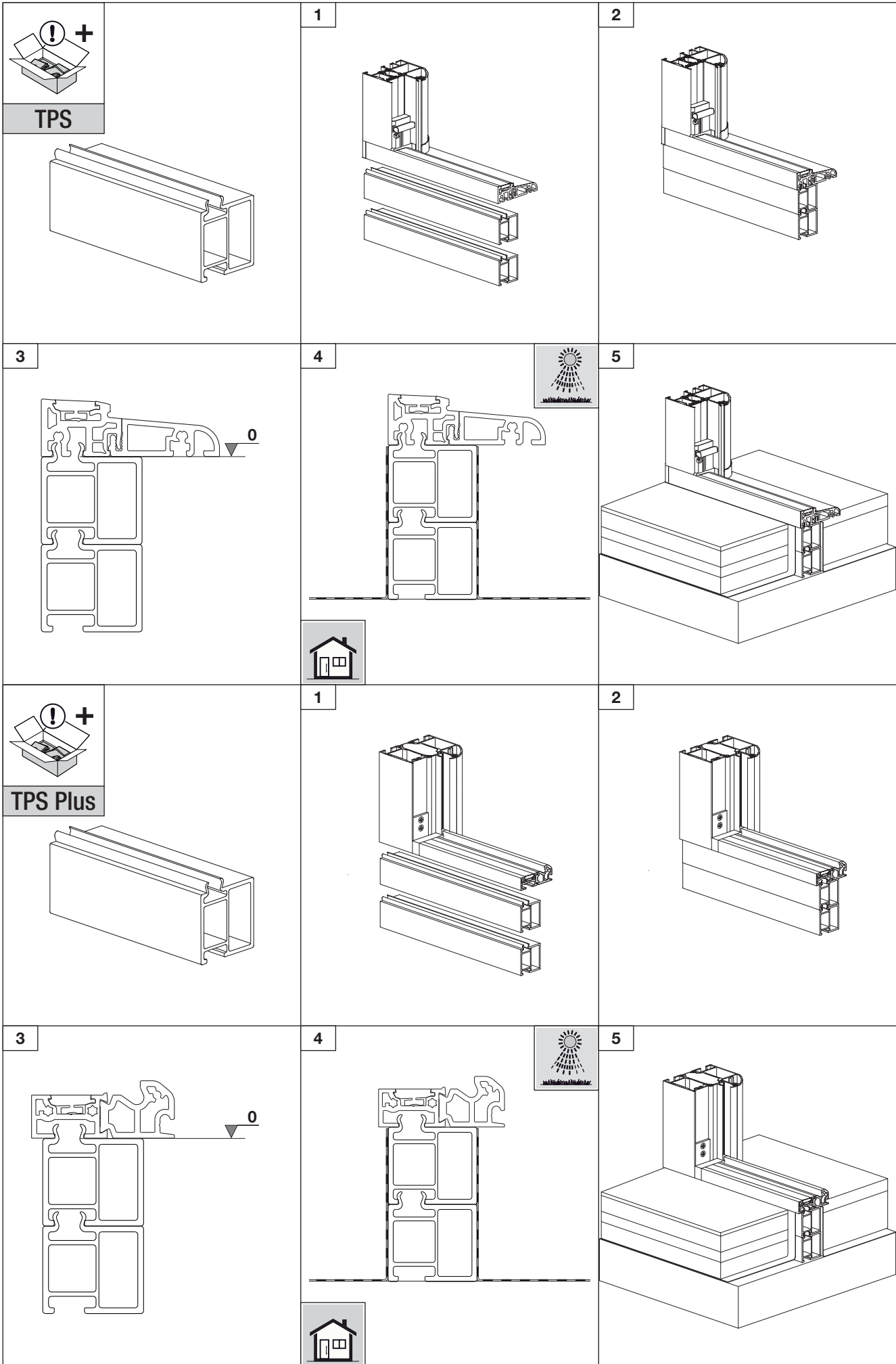

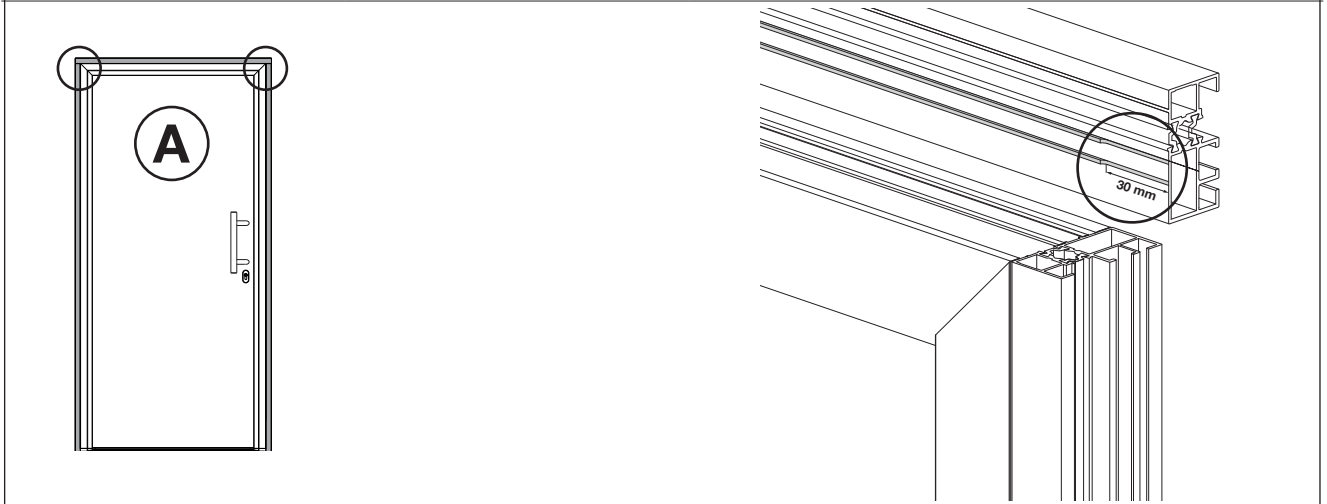
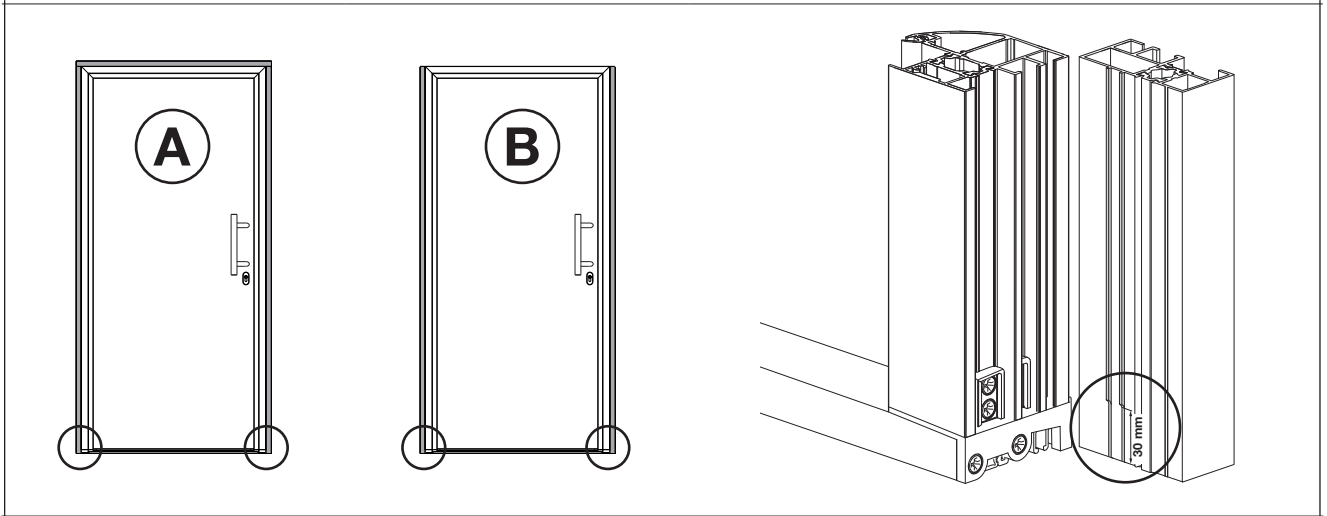
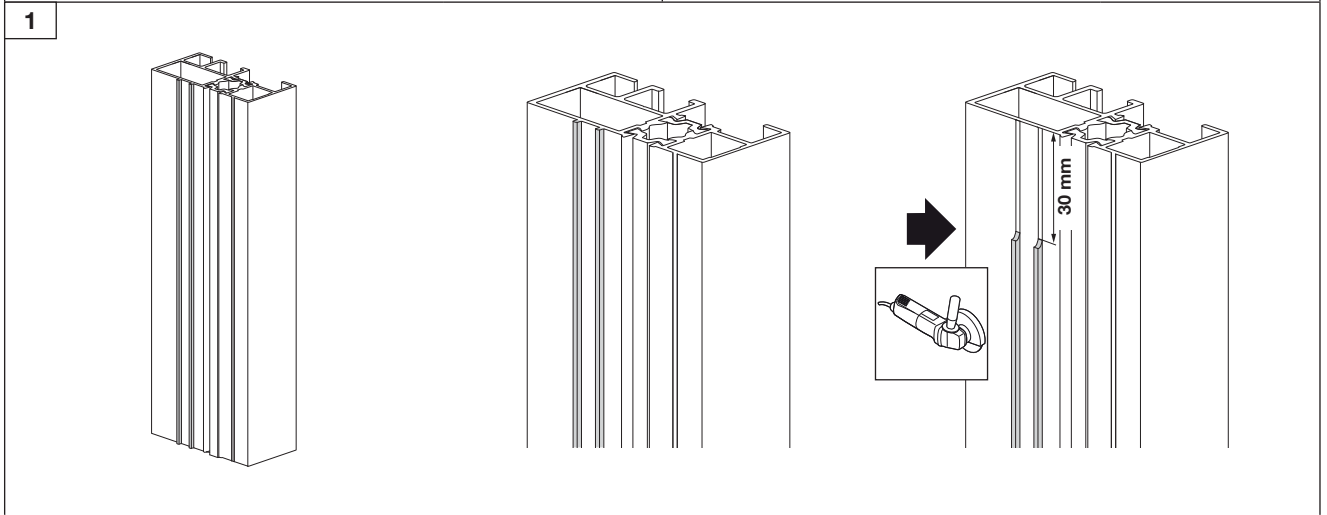
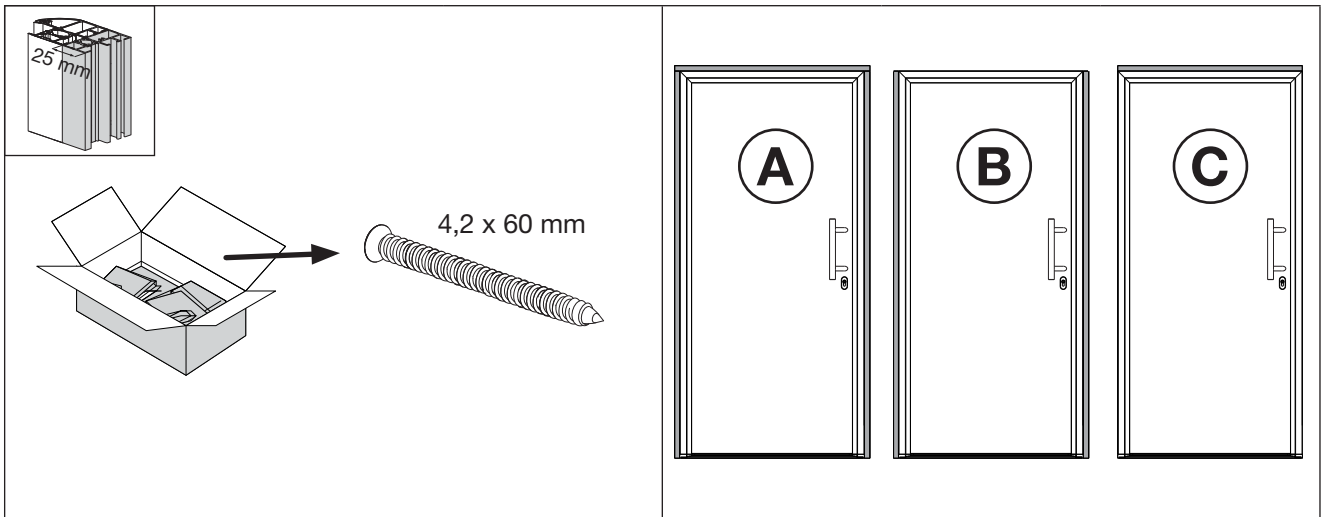

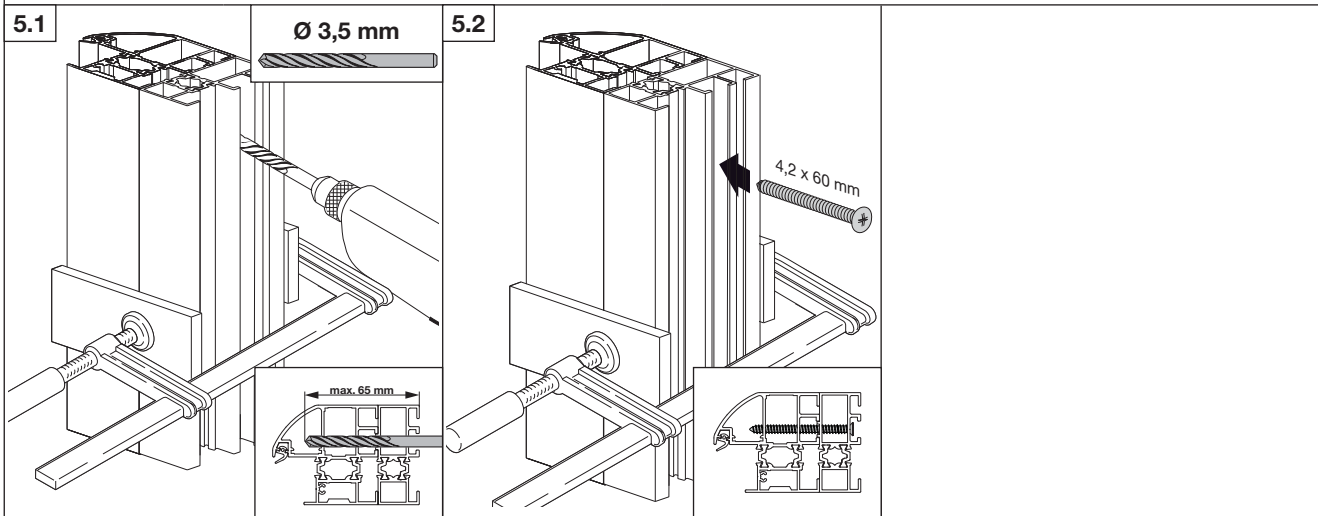
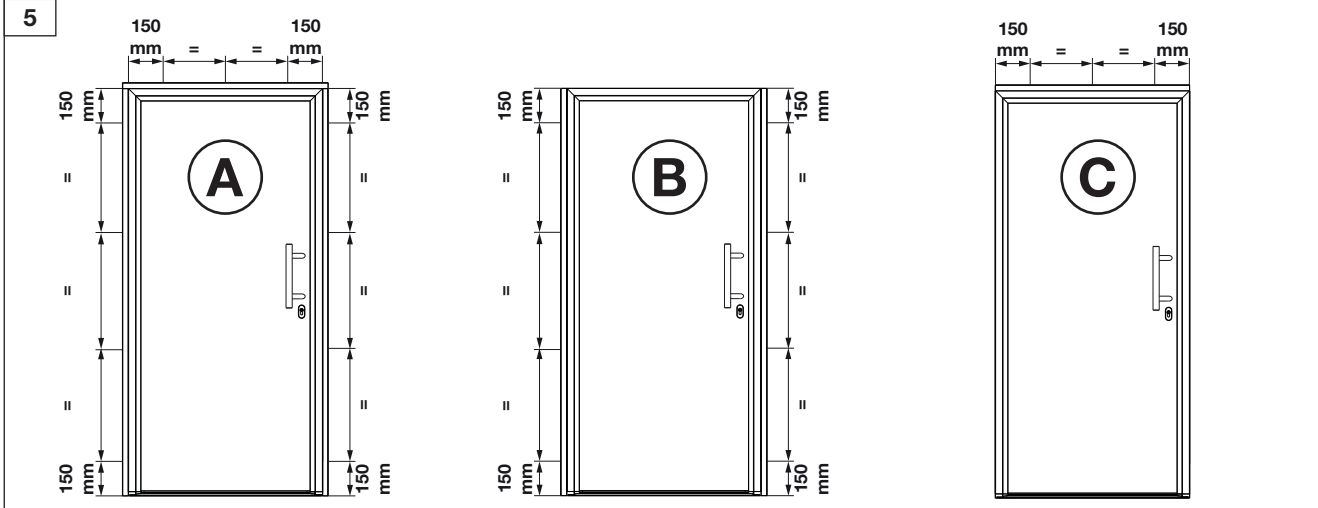
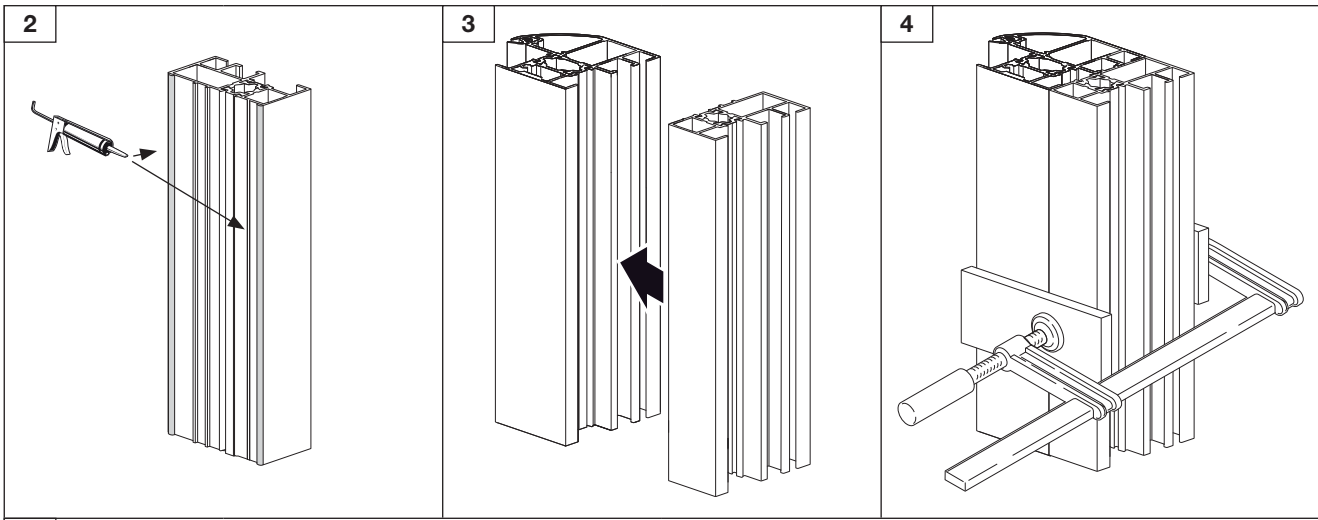

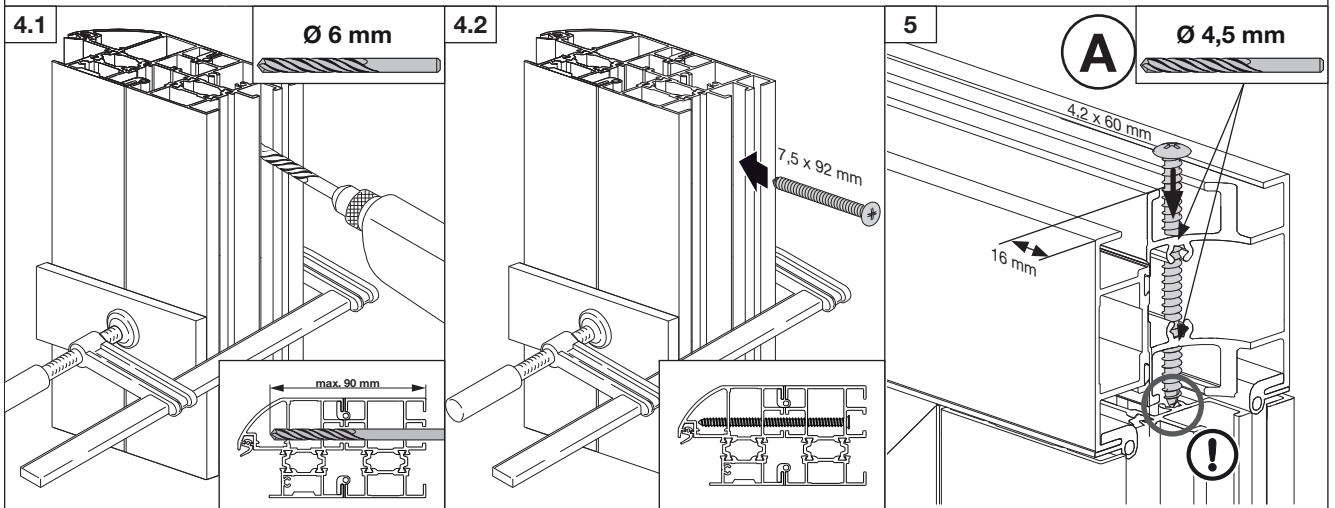
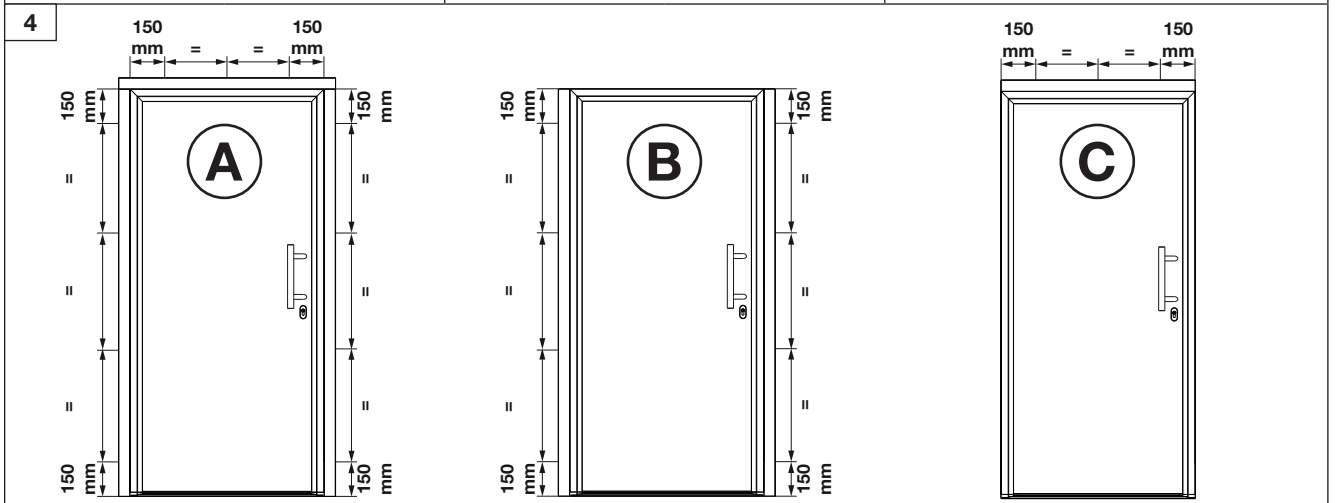
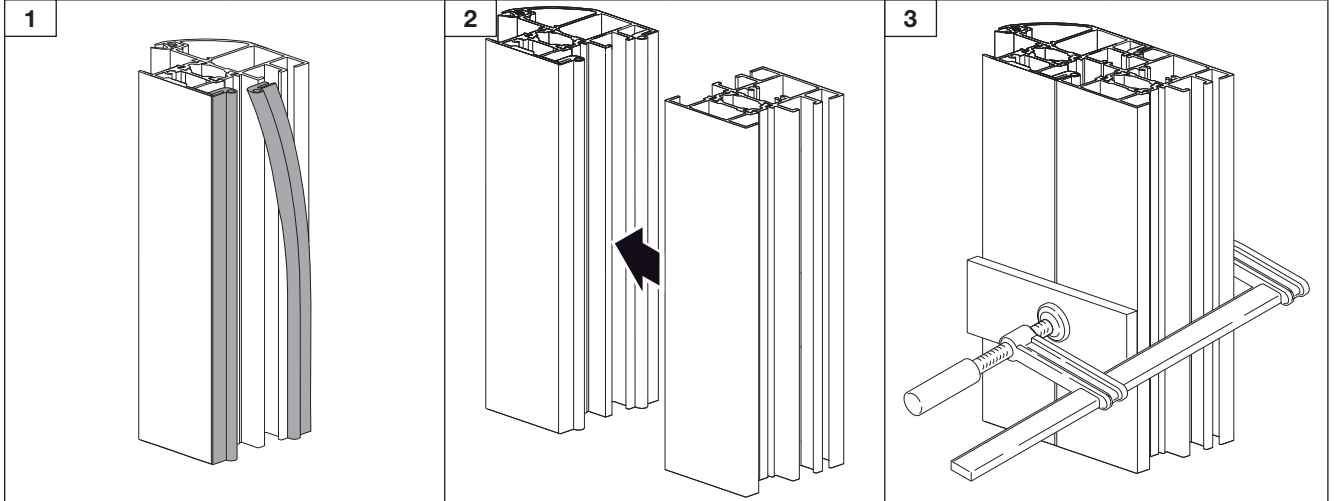
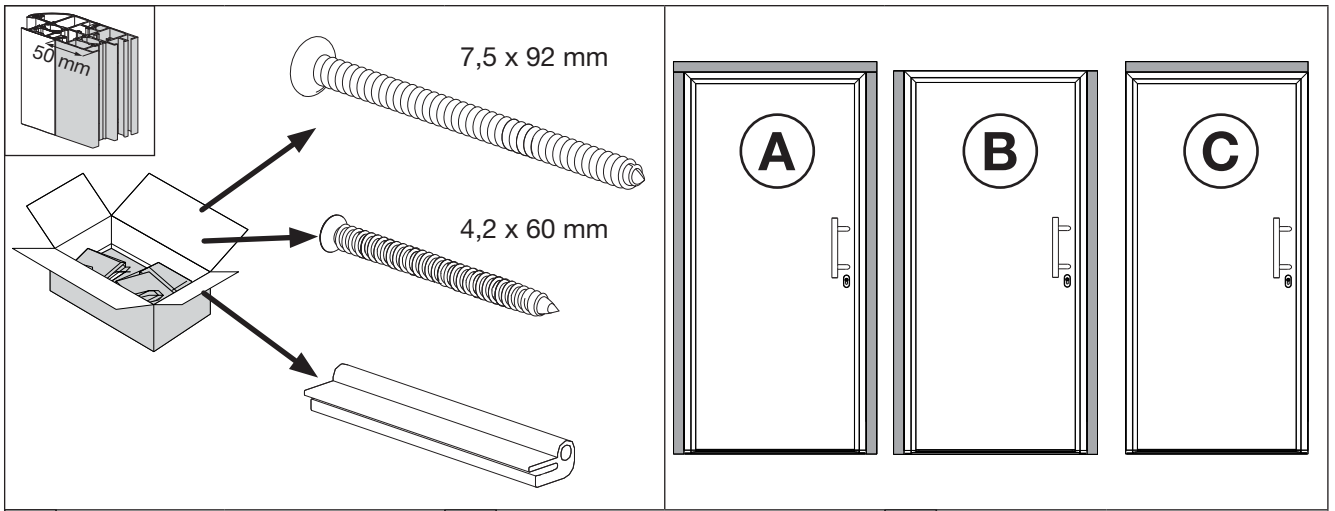

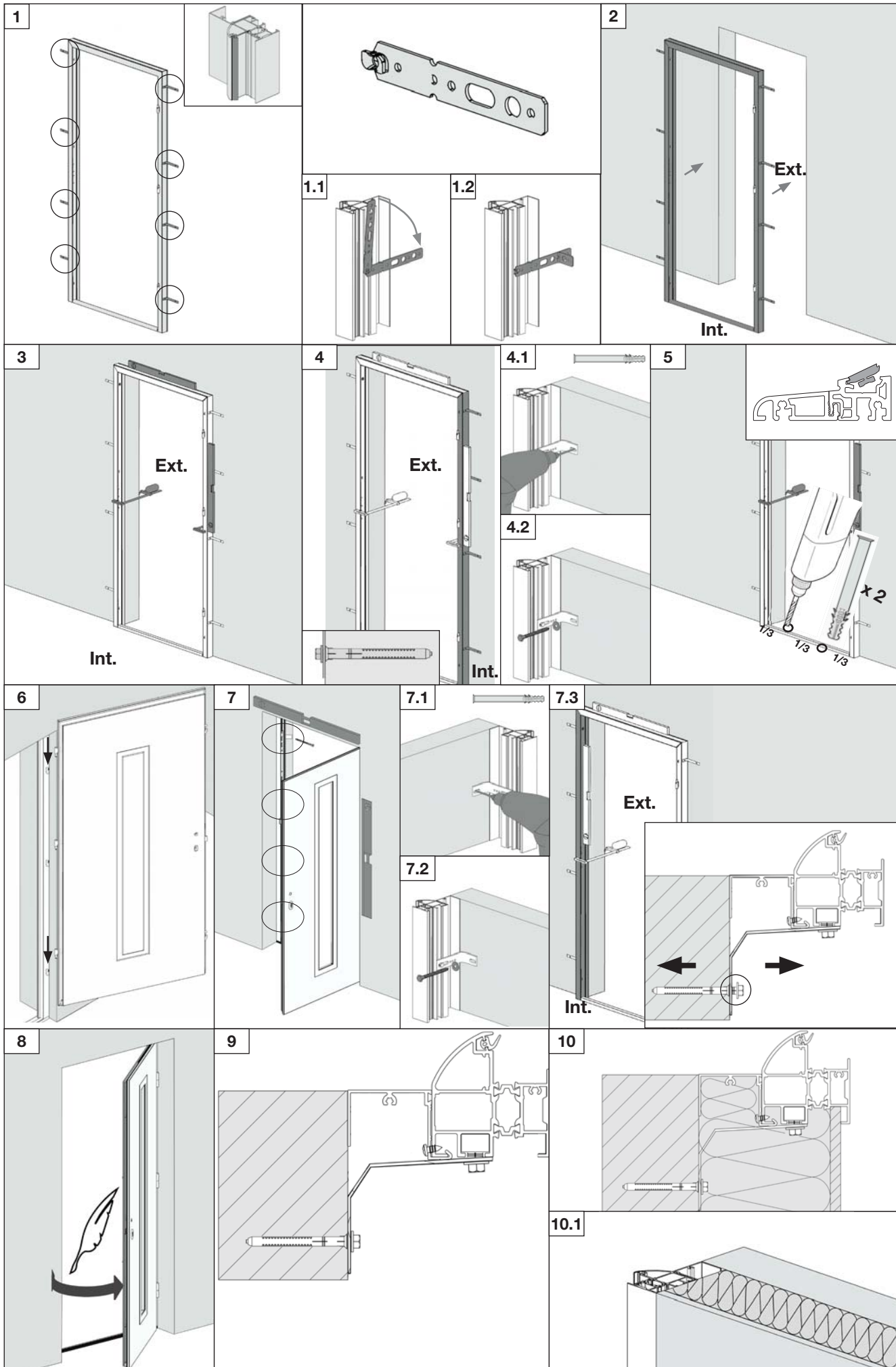

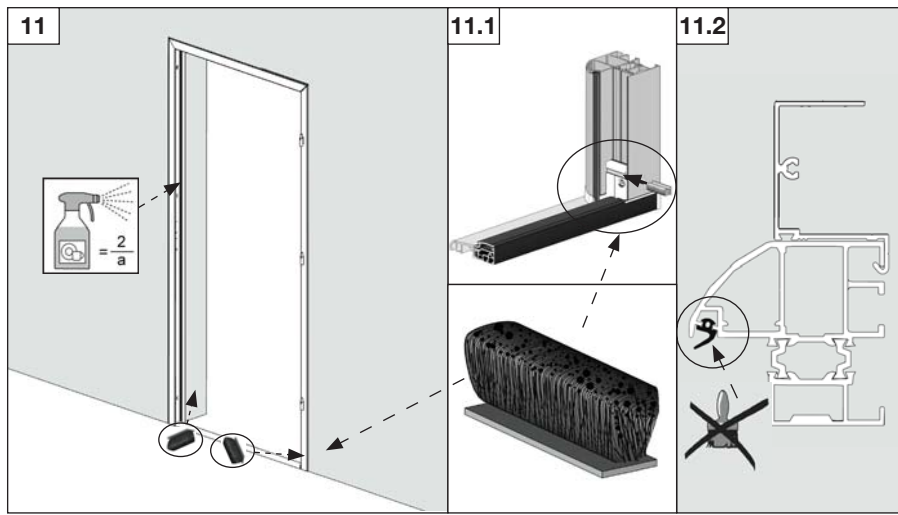

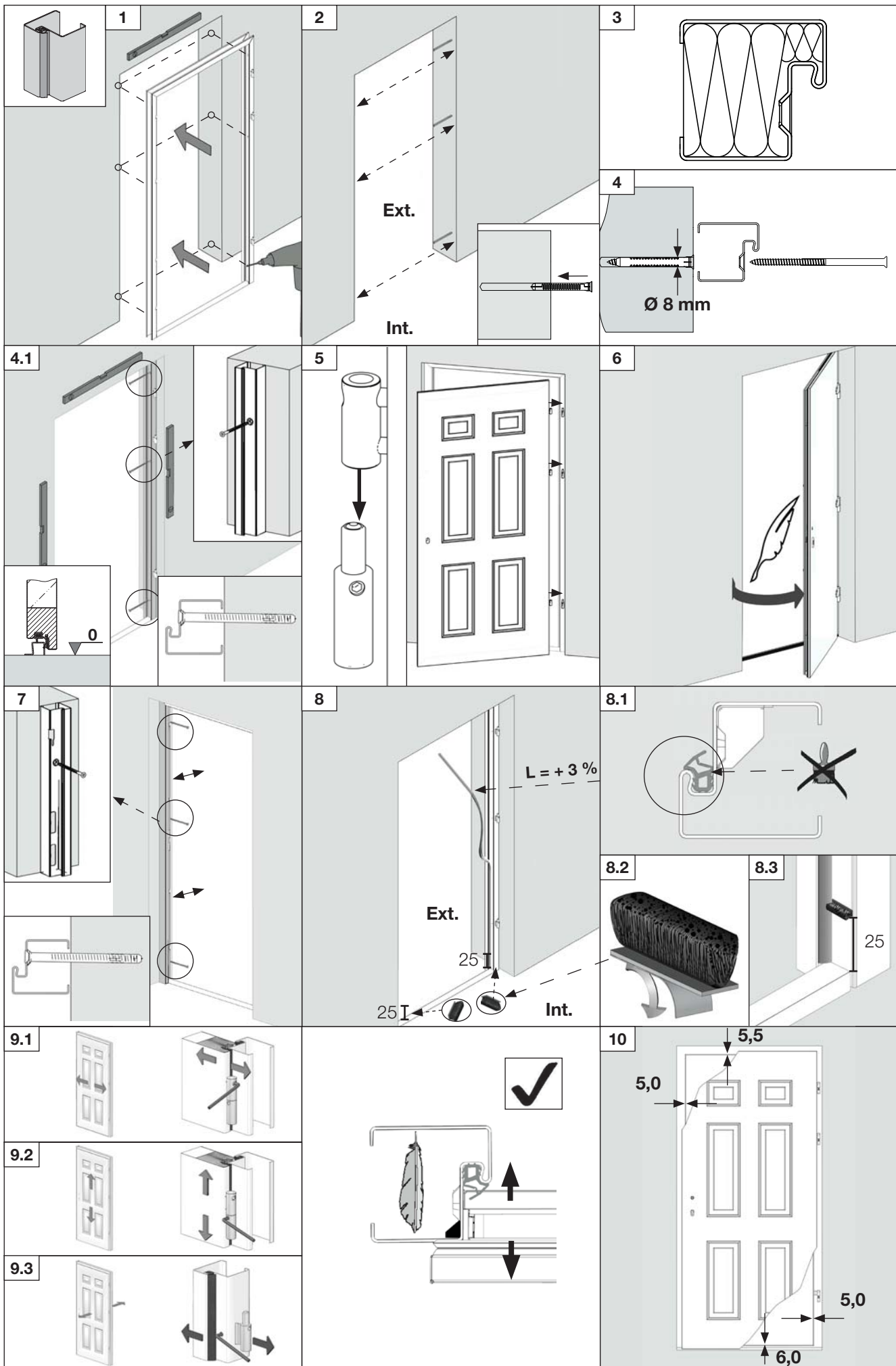

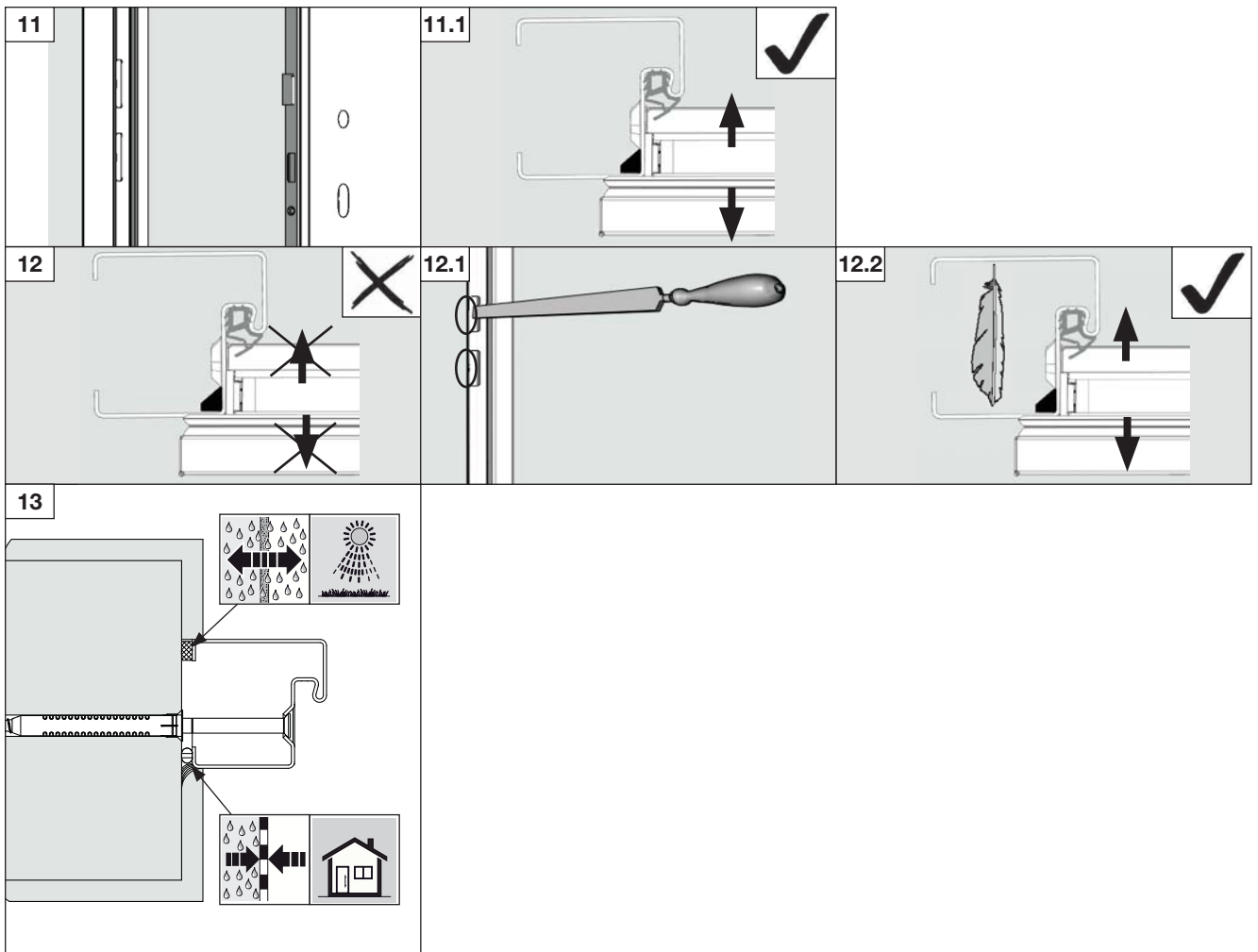

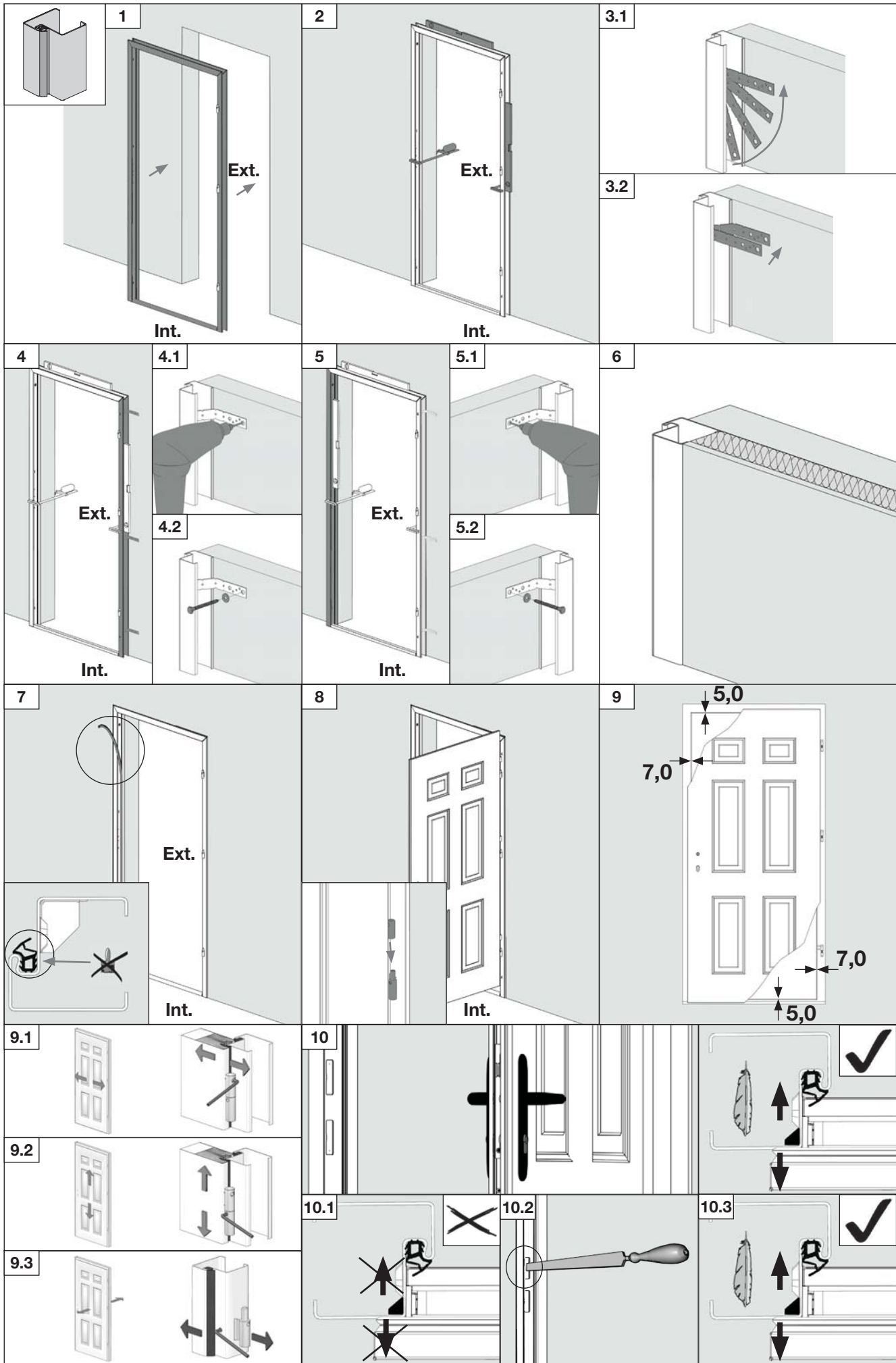

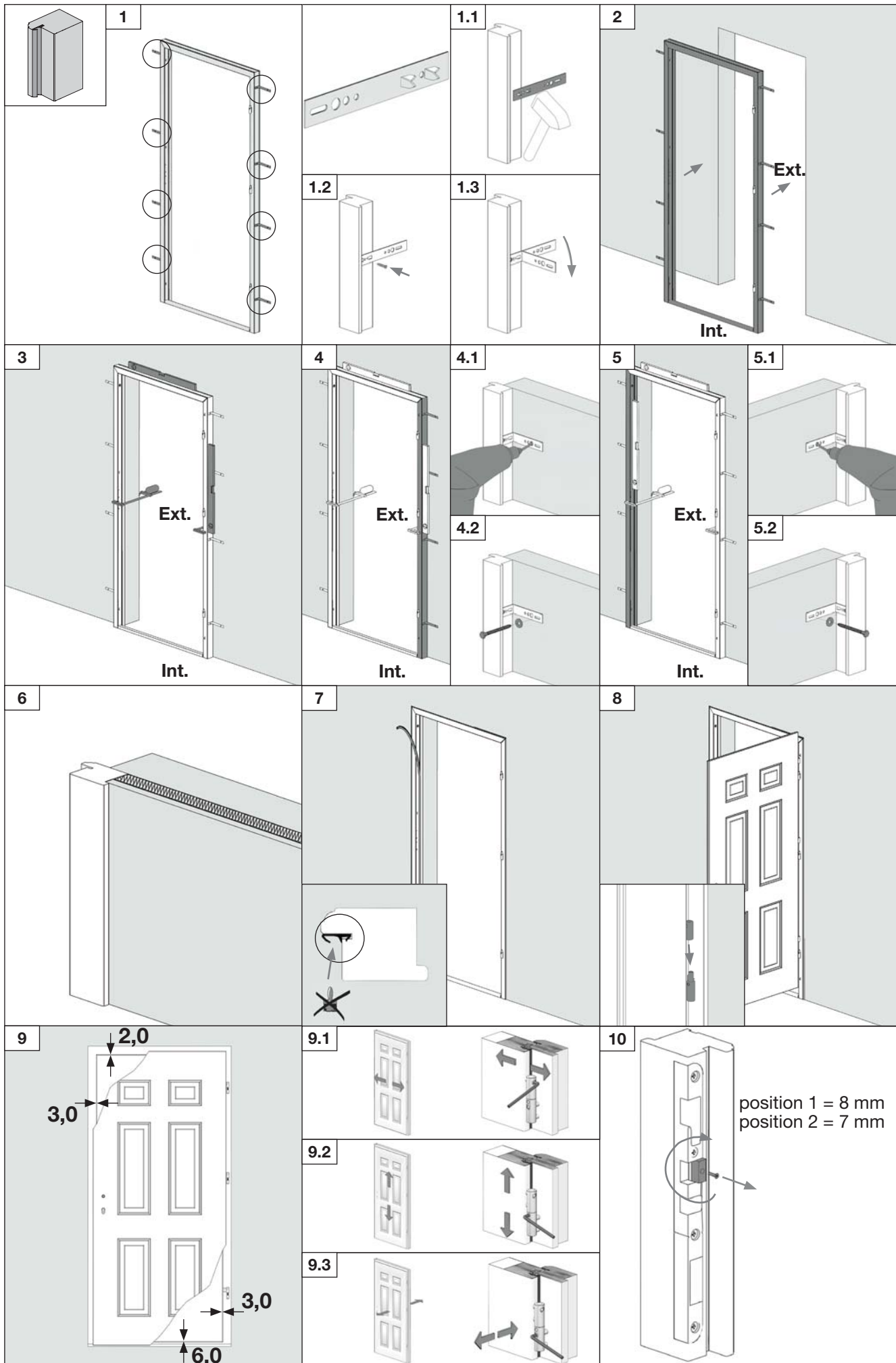

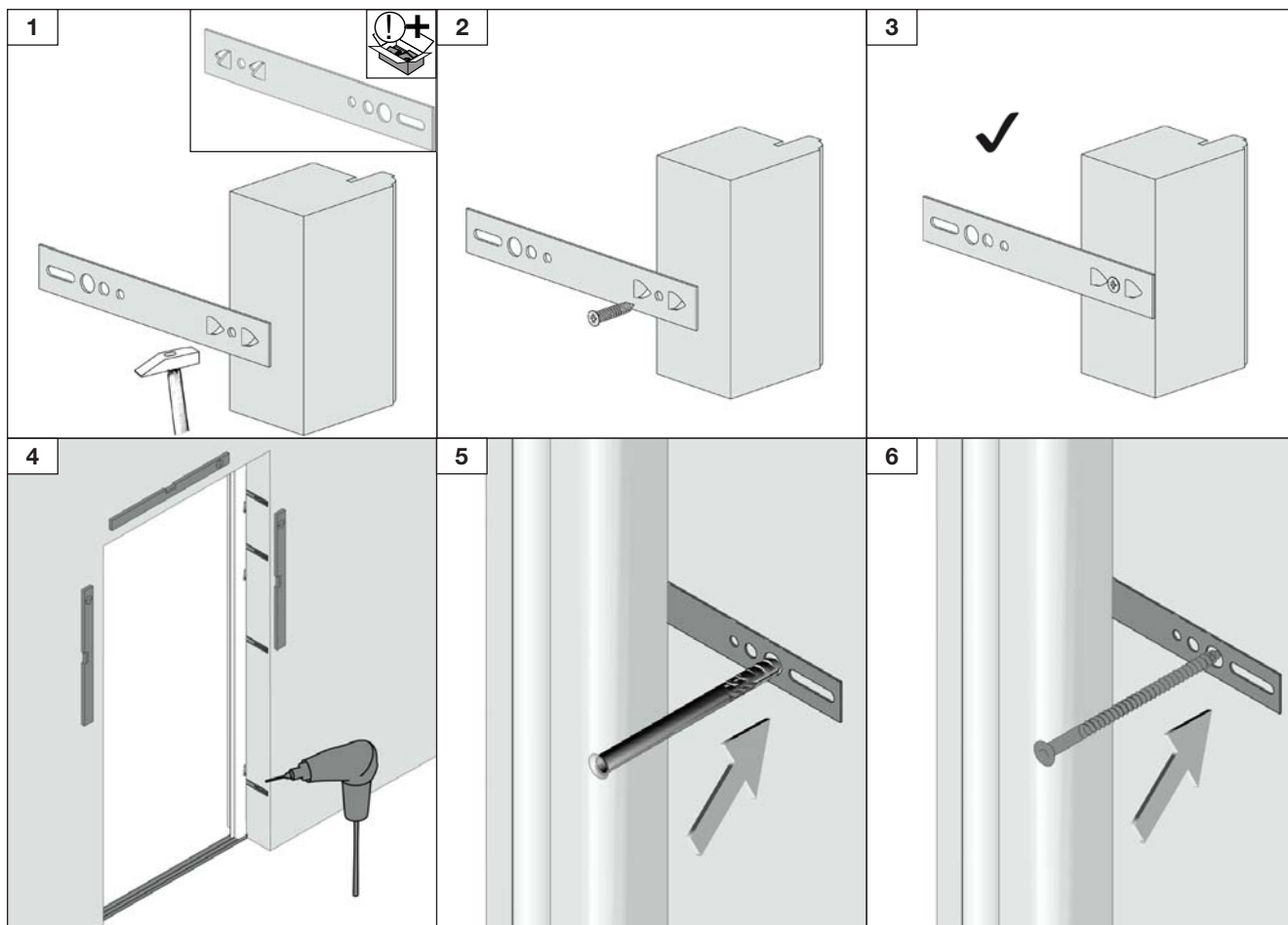

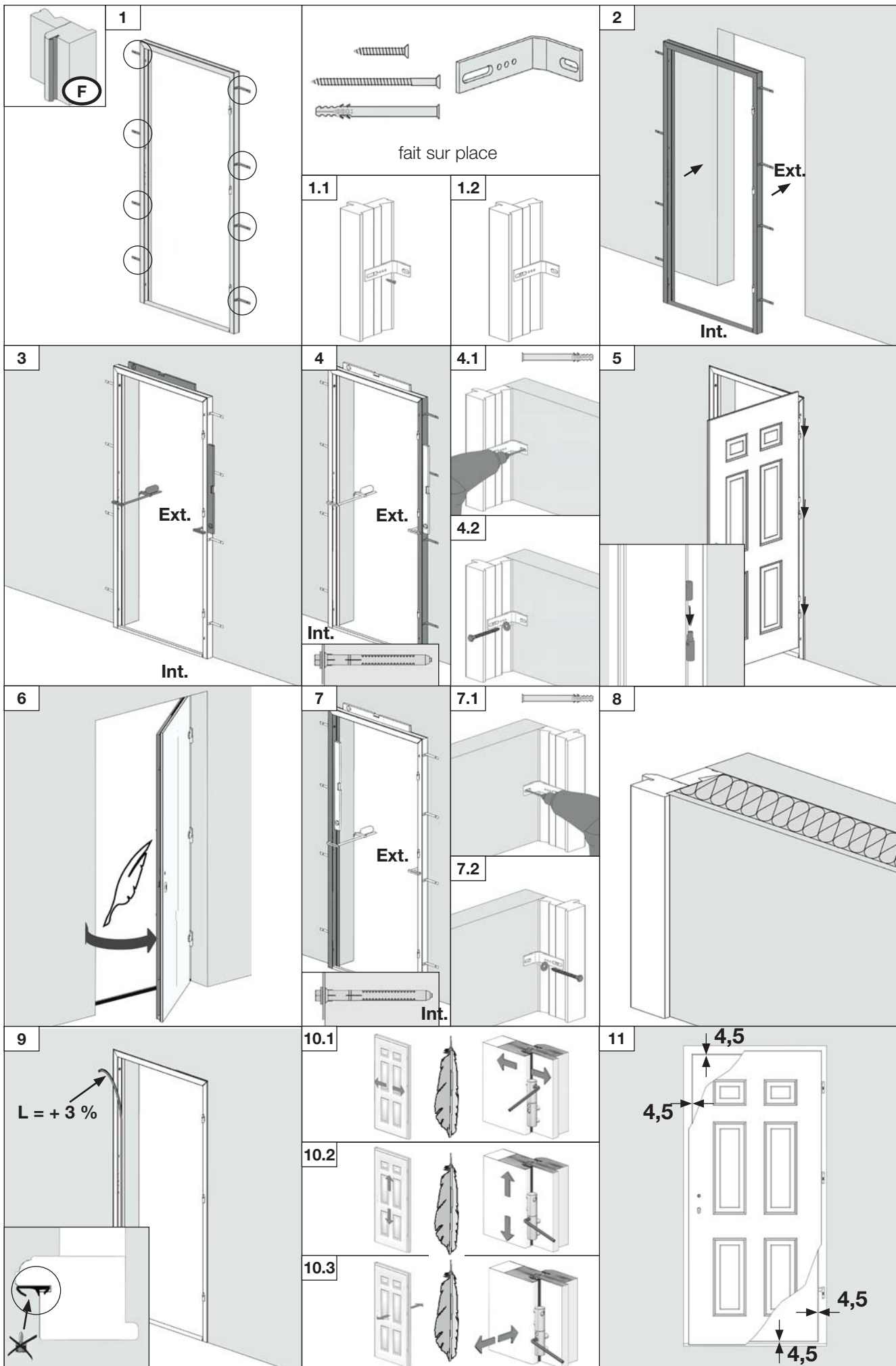

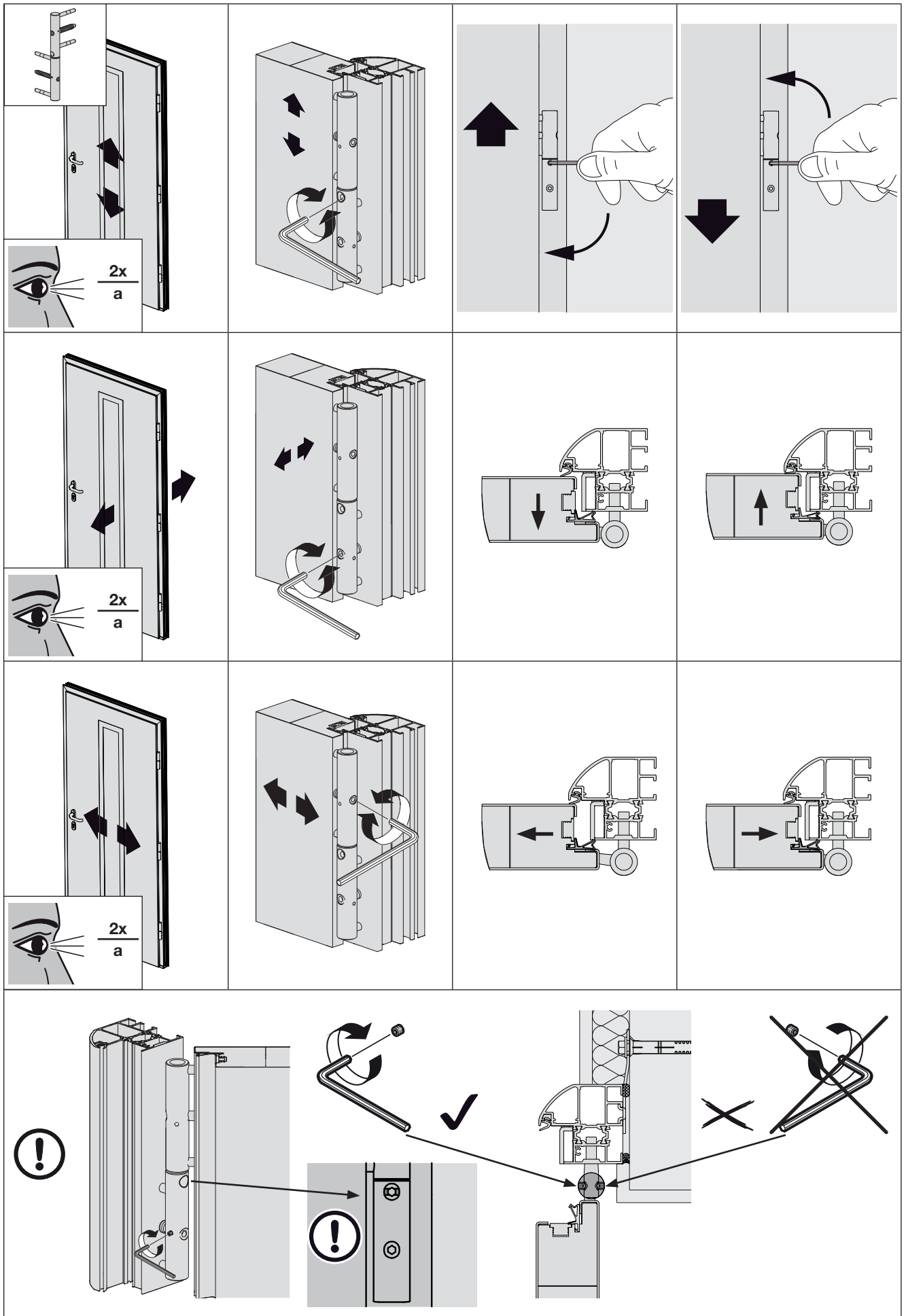

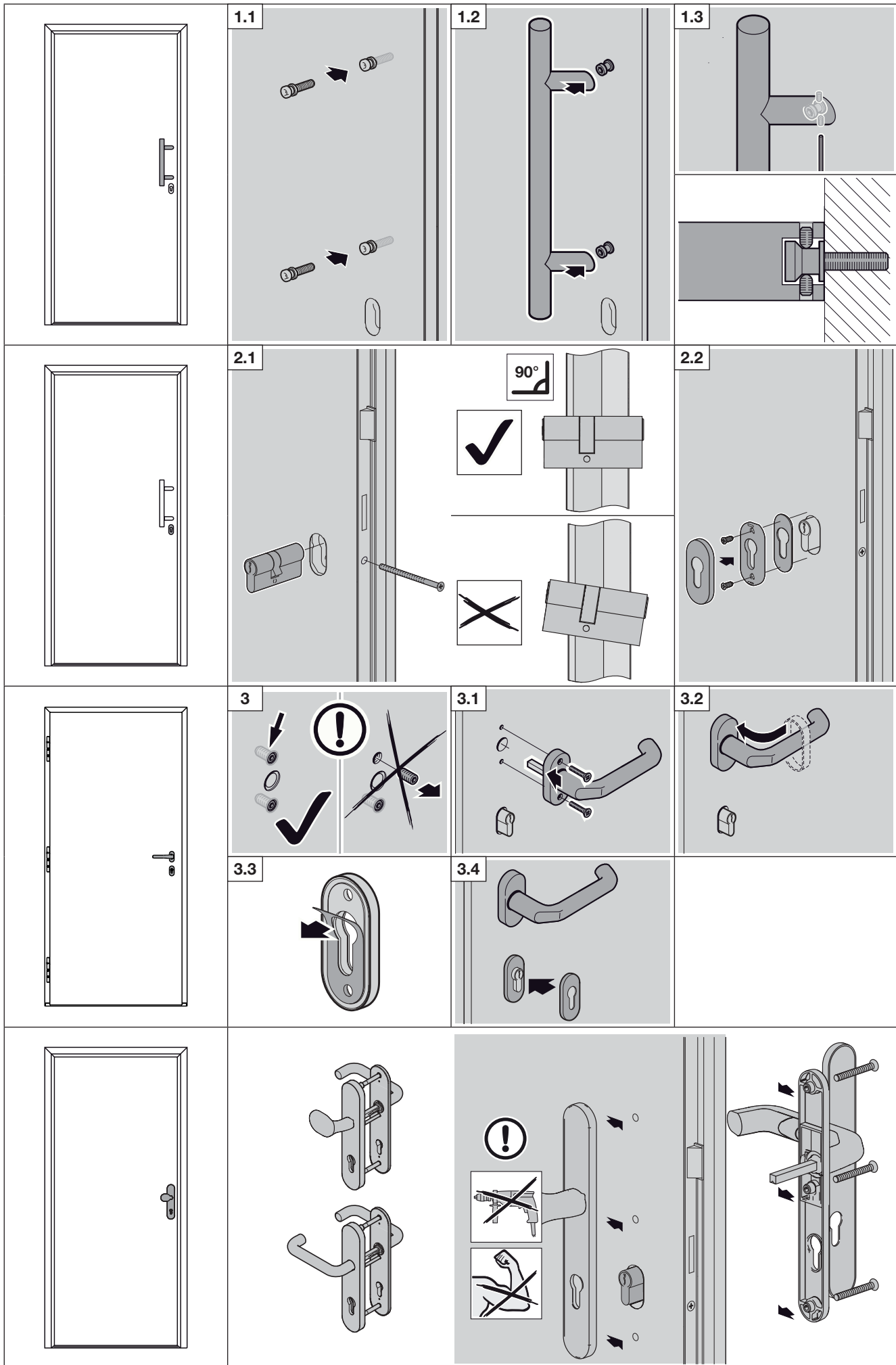

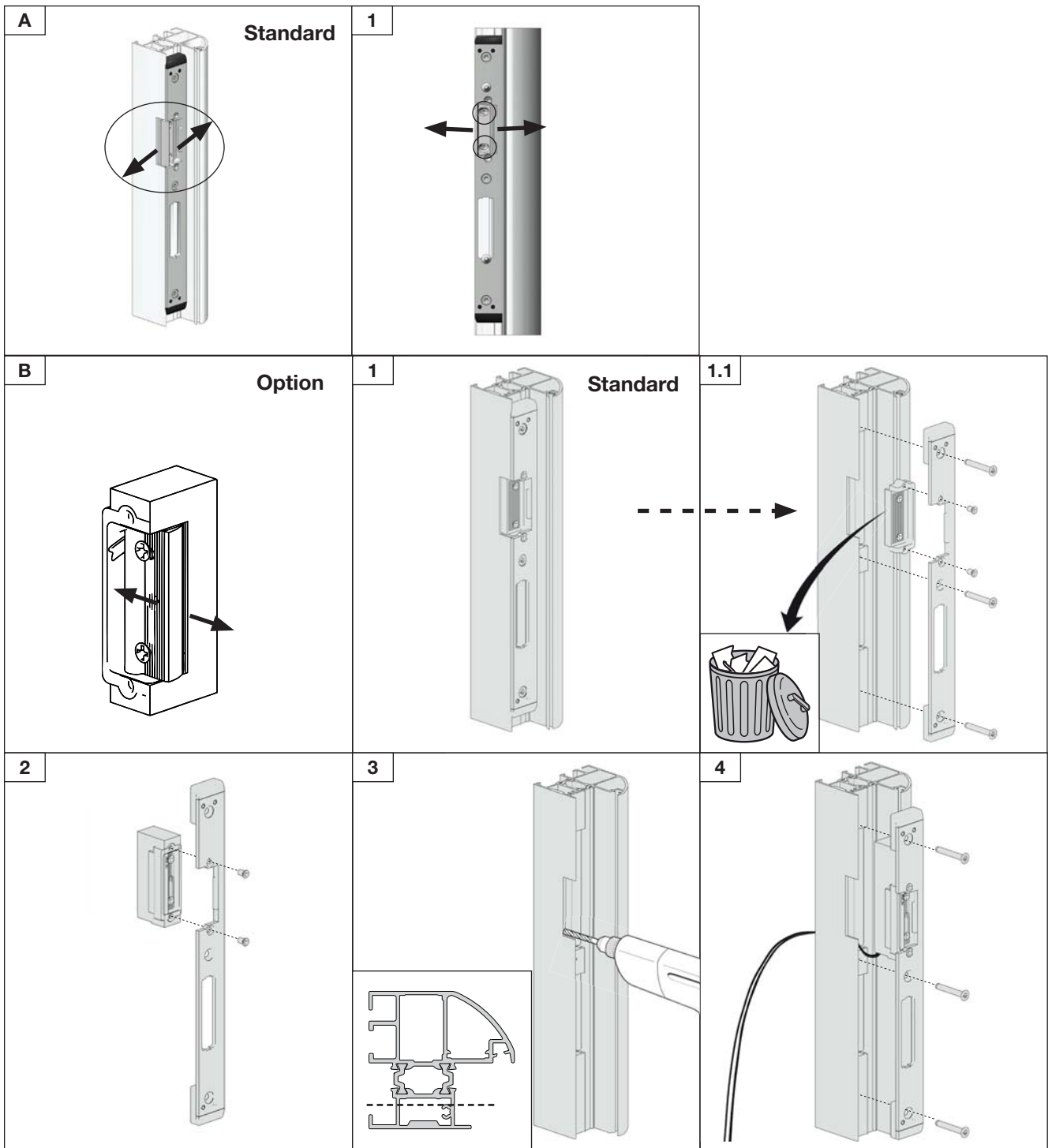

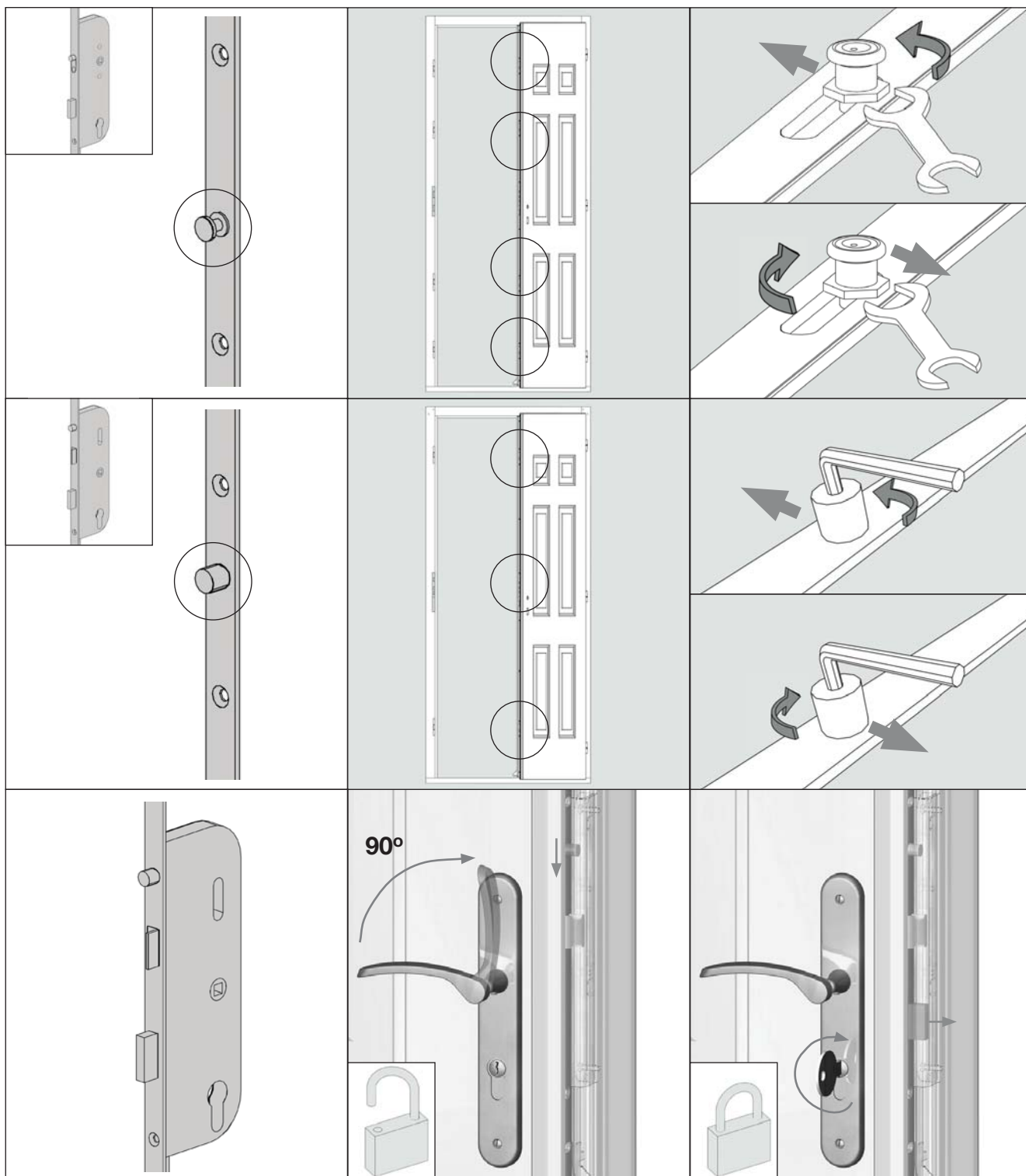

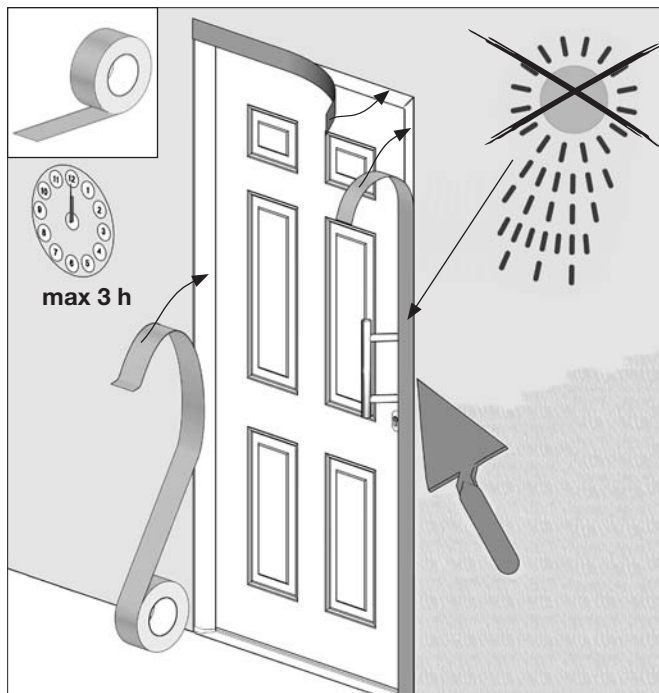

DE Bei der Verwendung von Abdeckklebebändern beim Einbau / Einputzen / Malern, dürfen nur schwach klebende Klebebänder verwendet werden

EN If using tape to protect surfaces during fitting/plastering/painting, only use masking tape that will not damage painted surfaces when removed!

FR En cas d'utilisation de films adhésifs de protection lors de la pose / du crépissage / de la peinture, seuls des rubans adhésifs à faible adhérence doivent être utilisés afin d'exclure tout endommagement des surfaces vernies lors du retrait !

ES Si se utilizan cintas adhesivas de protección para los trabajos de montaje/revoque/pintura, sólo deben utilizarse cintas adhesivas de adhesión ligera, para evitar que se produzcan daños en las superficies lacadas al retirar las cintas.

RU При использовании защитной клейкой ленты для монтажных, штукатурных и малярных покрасочных работ следует использовать только клейкие ленты с низкой адгезией, чтобы исключить, таким образом, повреждения лакированной поверхности.

NL Bij gebruik van afdekplakbanden bij montage/bepresteren/schilderen, mogen alleen zwak plakkende plakbanden worden gebruikt, die bij het verwijderen de beschadiging van gelakte oppervlakken uitsluiten!

IT Se si utilizza nastro adesivo per pacchi durante il montaggio/l'intonacatura/l'imbiancatura, quest'ultimo non deve avere troppa aderenza per escludere che la superficie laccata venga danneggiata alla sua rimozione!

PT Aquando da utilização de fitas adesivas de cobertura na montagem, limpeza ou lacagem, somente as fitas adesivas suaves devem ser utilizadas para que não causem danos nas superfícies lacadas quando forem removidas!

PL Do zabezpieczenia drzwi podczas montażu/tynkowania/malowania należy stosować wyłącznie słabe samoprzylepne taśmy malarskie, aby podczas usuwania nie spowodowały uszkodzenia lakierowanej powierzchni

HU A beépítés/takarítás/festés során a takaró ragasztószalag használatakor figyeljen arra, hogy csak gyengén ragadó ragasztószalagot használjon, ami az eltávolítás során nem károsítja a festett felületet!

CS Při používání maskovacích lepicích pásek během montáže/omítání/malování se smí používat jen slabě lepicí pásky, které při odstraňování vylučují poškození lakovaných ploch.

SL Pri uporabi kriticnih lepiacih pásek pri montaži/začistovanju/malovanju se smú použiti iba slabo lepiace pásky, ktoré pri odstraňovanju vylučia poškodene lakovanih površnih úprav!

DE Klebekraft
EN Adhesive power
FR Force de colle
ES Fuerza adhesiva
RU Клеящая способность
PL Siła klejenia

< 5 N / 25 mm

DE Reißkraft
EN Tear-out force
FR Force de ceder
ES Fuerza tensil
RU Разрывное усилие
PL Siła zrywania

<50 N / 25 mm

NO Dersom du bruker maskeringstape under monterings- eller malingsarbeid, må dette være en type maskeringstape med svakt lim, slik at de lakkerte overflatene ikke skades når den fjernes!

SV Om maskeringstejp används vid montering, målning och liknande arbeten får den inte ha för kraftigt klister som kan skada den lackerade ytan när man tar bort den.

FI Käytä asennettaessa, rapattaessa tai maalattaessa vain kevyesti kiinnittyviä peiteteippejä, jotka eivät poistettaessa vahingoita pintoja!

DA Ved brug af klæbebånd til afdækning i forbindelse med montering/pudse- og malerarbejde må der kun anvendes svagt klæbende klæbebånd, der ikke kan beskadige lakerede overflader!

SK Ob uporabi prekrivnih lepljivih trakov pri delih vgradnje/ometavanja/pleskanja se lahko uporabijo samo rahlo lepljivi prekrivni trakovi, ki pri odstranjevanju ne poškodujejo lakiranih površin!

TR Montaj/Sıva/Boya çalışmalarda sadece yapışkanlığı az olan ve bandi sökerken boyaya zarar vermeyen maskeleye bantlar kullanılmalıdır!

LT Kai montuojant, tinkuojant / dažant naudojamos dengiamosios lipnios juostos, leidžiama naudoti tik silpnai limpančias lipnias juostas, kurias nuėmus nebūtų pažeidžiami lakuoti paviršiai

ET Paigaldamisel/krohvimisel/viimistlemisel võib toote kinni katmiseks kasutada ainult selliseid kleeplinte, mille liim ei ole väga tugev, mis välistab eemaldamisel värvitud pealispindade kahjustada saamise!

LV Iebūvēšanas/apmetuma kārtas uzklāšanas/krašošanas laikā izmantojot nosedzošās līmlentes, drīkst izmantot tikai līmlentes ar vāju pielipšanas spēju, kas to noņemšanas laikā nesabojā nokrāsoto virsmu!

HR Ako se koriste ljepljive trake za prekrivanje prilikom ugradnje/žbukanja/bojenja dopušteno je koristiti samo slabo ljepljive trake, koje kod odstranjivanja ne oštećuju lakirane površine!

SR U slučaju korišćenja lepljivih traka za prekrivanje kod ugradnje/malterisanja/krećenja, dozvoljena je samo upotreba lepljivih traka koji nemaju jaku lepljivost, tako da se prilikom njihovog otklanjanja ne oštete lakirane površine!

EL Σε περίπτωση χρήσης κολλητικών ταινιών κάλυψης κατά την τοποθέτηση/εντοιχισμό/βαφή, επιτρέπεται να χρησιμοποιηθούν μόνο κολλητικές ταινίες που κολλάνε ελαφρώς, οι οποίες κατά την αφαίρεσή τους δεν θα προκαλέσουν ζημιές στις βαμμένες επιφάνειες!

RO La utilizarea de bandă adezivă pentru vopsit în timpul montării/tencuirii/vopsirii recomandăm folosirea unei benzi slab adezive, care la îndepărtare să nu afecteze suprafața vopsită sau lăcuită!

BG При използването на покривни ленти за лепене при монтаж/замазване/боядисване, могат да се използват само слабо лепливи ленти, които при отстраняване изключват повредата на боядисаните повърхности!