

Art - Nr.: 5204196 RE / HF 86776 / Stand: 10.2015 / Druck: 10.2015

DE**Anleitung für Montage, Betrieb und Wartung**

Aluminium-Haustür ThermoSafe / ThermoCarbon

EN**Instructions for Fitting, Operating and Maintenance**

Aluminium entrance door ThermoSafe / ThermoCarbon

FR**Instructions de montage, d'utilisation et d'entretien**

Porte d'entrée en aluminium ThermoSafe / ThermoCarbon

ES**Instrucciones de montaje, funcionamiento y mantenimiento**

Puerta de entrada de aluminio ThermoSafe / ThermoCarbon

RU**Руководство по монтажу, эксплуатации
и техническому обслуживанию**

Алюминиевая входная дверь ThermoSafe / ThermoCarbon

NL**Handleiding voor montage, gebruik en onderhoud**

Aluminium voordeur ThermoSafe / ThermoCarbon

IT**Istruzioni per il montaggio, l'uso e la manutenzione**

Porta d'ingresso in alluminio ThermoSafe / ThermoCarbon

PL**Instrukcja montażu, eksploatacji i konserwacji**

Aluminiowe drzwi zewnętrzne ThermoSafe / ThermoCarbon

CS**Návod k montáži, provozu a údržbě**

Hliníkové domovní dveře ThermoSafe / ThermoCarbon

SL**Navodila za montažo, delovanje in vzdrževanje**

Aluminijasta vhodna vrata ThermoSafe / ThermoCarbon

Table of Contents

1	About These Instructions.....	11
1.1	Warnings used.....	11
1.2	Symbols used.....	11
1.3	Abbreviations used.....	13
1.4	Colour code for leads, single wires and components... 13	
2	⚠ Safety Instructions.....	13
2.1	Fitter qualification.....	13
3	Fitting.....	13
3.1	Accessories.....	14
3.2	Determining the door position.....	14
3.3	Fitting types.....	14
3.4	Connection to building structure.....	14
3.5	Adjusting the fitting.....	14
3.6	Glazing.....	14
3.7	Electrical connections.....	14
3.8	Fitting break-in-resistant door sets.....	14
4	Description of S5/S7 Radio.....	15
4.1	LED display.....	15
4.2	Teaching in a radio code.....	15
4.3	Teaching in a radio code.....	15
4.4	Operation.....	15
4.5	Reset.....	15
5	Description of S5 / S7 Scan.....	15
6	Inspection and Maintenance.....	15
6.1	Checking the seating and sealing.....	15
7	Cleaning and Care.....	17
7.1	Surface.....	17
7.2	Cylinder.....	17
8	Dismantling and Disposal.....	17
9	Spare Parts.....	17
10	Declaration of conformity.....	17



..... 74

Dear customer,

We are delighted that you have chosen a high-quality product from our company.

1 About These Instructions

These instructions are divided into a text section and an illustrated section. The illustrated section can be found after the text section.

These instructions are **original instructions** as outlined in the EU-BpVO 305/2011. Please read and follow these instructions. They contain important information on the installation, operation and proper care and maintenance of the aluminium entrance door so that you can enjoy the use of this product for many years.

Please pay particular attention to all safety and warning notices.

Keep these instructions in a safe place for later reference!

Skilled fitting and thorough maintenance increase performance, availability and safety.

The texts and diagrams in this manual have been created with the greatest care possible. In order to provide a concise overview, not all detailed information on all variants and possible assemblies can be described. The texts and diagrams published in this manual are merely intended as examples.

Any guarantee for its completeness is excluded and does not justify a complaint.





Should you desire more information, or if special problems occur which are not described in detail in the manual, you may request information from the manufacturing plant.

These instructions are an important document for the construction file.











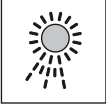

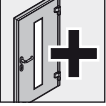
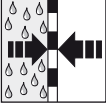
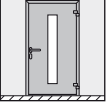
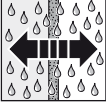
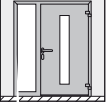



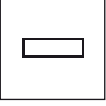
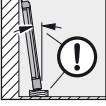

1.1 Warnings used

 DANGER
Indicates a danger that leads directly to death or serious injuries.
ATTENTION
Indicates a danger that can lead to damage or destruction of the product .

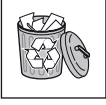
1.2 Symbols used

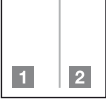
	Important note for avoiding damage to property
	Permissible arrangement or activity
	Non-permissible arrangement or activity
	See text section
	See illustrated section

Dissemination as well as duplication of this document and the use and communication of its content are prohibited unless explicitly permitted. Noncompliance will result in damage compensation obligations. All rights reserved in the event of patent, utility model or design model registration. Subject to changes.

	See separate Fitting Instructions for the control or for the additional electrical control elements		Summer
	Electrical voltage		Condensation
	Optional components, to be ordered as accessories		Vapour diffusion proof
	Single - leaf door		Open to vapour diffusion
	Door with side element		Tighten the screws by hand
	Door opening inwards		Tighten the screws firmly
	Door opening outwards		Inspect
	Support blocks		Maintenance-free
	Spacing blocks		Placing door leaf on the floor
	House interior		Remove and dispose of component or packaging
	Not permissible according to DIN 4108		In the illustrated section, this indicates work steps that must be performed in succession
	House exterior		Break-in-resistant component RC 2 acc. to DIN EN 1627:2011
	Winter		Break-in-resistant component RC 3 acc. to DIN EN 1627:2011



Break-in-resistant component **RC 4**
acc. to DIN EN 1627:2011



Attack side



Permanently open

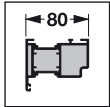

ThermoSafe

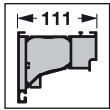

ThermoCarbon

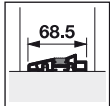

ThermoSafe threshold

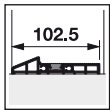

ThermoCarbon threshold

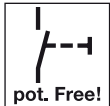

Volt-free contact



Contact



To be connected / fitted on-site



To be connected / fitted at the factory

GN = green
GY = grey
YE = yellow
WH = white
GN / YE = green / yellow

2 Safety Instructions

DANGER

Danger to life while fitting the entrance door

During fitting, the door or door frame can fall and kill persons.

- ▶ Prior to and during fitting, secure the door and frame against falling over.
- Comply with the basic rules in DIN 4108 *Thermal insulation and energy economy in buildings* when fitting the aluminium entrance door.
- Make sure to comply with the applicable standards, directives, regulations, ordinances and the generally accepted rules of technology.
- Protect your door until construction is completed by covering it with foil and tape to avoid damages. But keep in mind that tape can leave residue or damage to the coating, especially under prolonged exposure to the sun.
- Identify suitable fastenings according to the local conditions and have them on hand.
- Anchor the aluminium entrance door at all of the provided fixing points in the wall.
- Always maintain the required edge and centre line spacing of the plugs depending on wall type, as well as the fitting information and handling guidelines of the plug manufacturer!
- Contact surfaces to be sealed with silicon and sealant material must first be cleaned, such as
 - Profile surfaces
 - Edge compound of the pane
- Only use adhesive and sealant materials that are suitable for this application and compatible with the product materials. Follow the handling guidelines of the respective manufacturer.
- Electrical work may only be carried out by qualified electricians.
- EC Directive 2006/42/EC is to be complied with for aluminium entrance doors with automatic door operators.

2.1 Fitter qualification

In order to ensure proper installation of the aluminium entry door, only assembly technicians with commensurate training may be charged with the task.

ATTENTION

Impaired function

Missing or modified components will impair the function of the entrance door.

- ▶ Do not alter or remove any components.
- ▶ Fasten all components described in the manual.

1.3 Abbreviations used

OFF (FFL) Finished floor level

1.4 Colour code for leads, single wires and components

The colour abbreviations for lead, wire and component identification follows the international colour code in accordance with IEC 757:

BK = black
BN = brown

3 Fitting

- ▶ To ensure simple and professional fitting, carefully go through all the work steps shown in the illustrated section.
- ▶ Before fitting the door, check whether any attached parts have to be fitted (see **Figure 3**).
- ▶ Remove the transport protection before fitting (see **Figure 2.3**).
- ▶ Fastening and sealing materials are not included in the scope of delivery.

ENGLISH

NOTE:

It is important that you use the fixing points prepared at the factory.

The fixing points indicated in the fitting instructions are only general and may deviate from the fixing points prepared at the factory.

3.1 Accessories

- K3 door / side element / transom light (see **Figures 3.1 / 3.2**)
 - VP25 / VP50 extension (see **Figure 3.3a**)
 - VP100 / VP150 extension (see **Figure 3.3b**)
 - VPE20 / VPE50 one-piece extension (see **Figure 3.4**)
 - KE135 / KE90 corner profiles 135° / 90° (see **Figures 3.5a / 3.5b**)
 - K3S static profile (see **Figure 3.6**)
- Fixing material for accessories is part of the scope of delivery.

3.2 Determining the door position

- ▶ Determine the door position depending on the on-site fastening options, type of wall and the required edge and centre line spacing for the plug.
- ▶ If possible, position the door so that it is within the insulation layer of the wall. With monolithic or single-shell brickwork, position the door as close as possible towards the building interior side. Observe the isothermal lines (see **Figure 1**).

3.3 Fitting types

- Anchor fitting (see **Figures 10 – 12**)
- Plug-and-screw fitting (see **Figures 10 – 12**)
- Frame screw fitting (see **Figures 10 – 12**)

NOTE:

Each fixing point must be back-blocked resistant to pressure.

- Unhinge the door leaf (see **Figures 2.5 / 15a / 15b**).

ATTENTION**Impaired function**

Non-compliance with the handling guidelines will impair the function of the entrance door.

- ▶ With fixing and sealant material, follow the handling guidelines of the respective manufacturer.

3.4 Connection to building structure

1. Fill the space between the door frame and brickwork with insulation material (such as fibreglass or mineral wool).
2. Push in the round cord.
3. Seal the joint on the interior so that it is impervious to vapour diffusion.
4. Make the exterior groove open to vapour diffusion with pre-compacted strips (see **Figure 11.1 / 17**).

3.5 Adjusting the fitting

- Horizontal and vertical door leaf adjustment, contact pressure adjustment (see **Figures 15a – 15b**).

ATTENTION**Limiting the door opening angle** (see **Figure 15b.1**)

The door opening angle must be limited to 105° on site.

- ▶ Otherwise, damage to the hinges or frame is to be expected.

3.6 Glazing

- Insertion and replacement of the glass panes or infills (see **Figure 14a / 14b**).
- Blocking suggestions (see **Figure 14a / 14b**)

- Secure blocking against falling (e.g. with Pattex adhesive).

3.7 Electrical connections**⚠ DANGER****Mains voltage!**

Contact with the mains voltage presents the danger of a deadly electric shock. For that reason, observe the following warnings under all circumstances:

- ▶ Electrical connections may only be performed by a qualified electrician!
- ▶ The on-site electrical installation must conform to the applicable protective regulations!
- ▶ Qualified electricians must ensure compliance with the national directives for the operation of electrical devices!

Depending on the length of the power supply cable, it must have at least the following cross-section:

10 m	0.50 mm ²
40 m	0.75 mm ²
50 m	1.00 mm ²
75 m	1.50 mm ²
125 m	2.50 mm ²

3.8 Fitting break-in-resistant door sets

The fitting instructions in this section give additional tips on fitting break-in-resistant door sets with resistance classes RC 2 to RC 4 acc. to DIN EN 1627: 2011 (see **Figures 18 - 21**).

Only by a professional fitting in accordance with these instructions will the door sets be equipped with break-in-resistant features.

3.8.1 Permissible walls

The required break-in-resistance can only be obtained if the adjacent walls meet the requirements according to **Tab. 1 – Tab. 3**.

3.8.2 Permissible wall connections

The wall connections defined in **Image 10.2 a – 10.2 j** are permissible. Expert fitting must be verified with a fitting certificate.

3.8.3 Safety relevant components

The required break - in - resistance can only be obtained if the used infills meet the following requirements.

Minimum requirement for the side element / transom light infills:

ThermoSafe		
Resistance class	RC 2	RC 3
Glazing resistance class according to EN 356	P4 A	P5 A
Placement of the safety pane	Opposite side	Attack side
Hörmann panel with or without glass	Aluminium panel	

ThermoCarbon			
Resistance class	RC 2	RC 3	RC 4
Glazing resistance class according to EN 356	P4 A	P5 A	P7 B
Placement of the safety pane	Opposite side	Attack side	Opposite side
Hörmann panel with or without glass	Aluminium panel		

The exchange of safety-relevant components (e.g. fittings, locks and infills) can lead to a loss of door set resistance.

Minimum requirements for the fittings:

Resistance class	RC 2	RC 3	RC 4
EN 1303 (see Figure 20) Locking cylinder (position 7)			
Locking cylinder (position 8)	4 1	4 1	6 2
EN 1906 Protective fitting (position 7)	Integrated into the construction		
EN 12209 Locks (position 7)	3 ¹⁾	4 ¹⁾	7 ¹⁾

¹⁾ The suitability of the locks must additionally be verified through tests according to DIN EN 1627 or as part of an expert's opinion.

Be sure to observe the following fitting instructions:

- The visible gap of 5 ± 1 mm between frame and leaf must be observed (see **Figure 21**) so that the lock bolts fully extend into the lock plate openings.
- Connected ThermoCarbon side elements are to be secured all-round and according to the specifications for infill attachment of the respective RC classification (see **Figures 19c - 19e**).

3.8.4 Additional instructions for fitting

- Install the frames vertically and properly aligned (see **Figure 11**).
- In the areas described below, back-fill the spaces between frame and walls with a rot-free material to withstand pressure:
 - Hinges
 - Infill
 - Locking
 - Fixing points
 - On the upper and lower corners

By taking suitable precautions (e.g. silicone), make sure that the pressure-resistant back-packing is not able to shift (see **Figure 10.2**).

3.8.5 Instructions for the user

- Break-in-resistant components only provide burglar resistance in a closed, locked, and secured state and when the key has been removed!
- Anti-panic locks are not permissible in combination with break-in-resistant doors!

4 Description of S5/S7 Radio

SecureConnect volt-free control (see **Image 7c / 7d / 7e**)

If the SecureConnect is to be controlled by intercom/buttons on which voltage is applied at the output, this cable must be switched to volt-free by fitting a coupling relay. Coupling relay for standard cases (12 V AC) in accessories.

4.1 LED display

Blue (BU)

Condition	Function
Illuminated briefly	A valid radio code was discovered for channel 1
Illuminated long once	A valid radio code is discovered that has been stored on both channels
Flashes slowly	Receiver is in the learn mode for channel 1
Flashes quickly after slow flashing	A valid radio code was discovered during the learning

Flashes slowly for 5 seconds	Device reset is being implemented or completed
Flashes quickly for 2 seconds	
Off	Operation mode

Programming button **P** (**P** button)

4.2 Teaching in a radio code

To activate / switch a channel:

- Press the **P** button once to activate channel 1.

To abort the learn mode:

- Press the **P** button 3 times, or wait for the timeout. Timeout

If no valid radio code is recognised within 25 seconds, the receiver automatically returns to the operation mode.

4.3 Teaching in a radio code

(see **Figure 7e**)

- Press the **P** button to activate the desired channel.
 - The blue LED will flash slowly for channel 1.
- Put the hand transmitter, whose radio code is to be inherited, into the **Inheriting / Transmitting** mode. If a valid radio code is recognised, the LED flashes quickly in blue then goes out. **The receiver is in the operation mode.**

4.4 Operation

In the operation mode, the receiver signals the recognition of a valid radio code by illuminating the blue LED.

NOTE:

If the radio code for the taught-in hand transmitter was copied from another hand transmitter, the hand transmitter button must be pressed a second time during **initial** start-up.

A valid radio code

channel 1 is discovered = The LED is illuminated briefly once

4.5 Reset

All radio codes are deleted by the following steps:

- Press and hold the **P** button.
 - The LED slowly flashes in blue for 5 seconds.
 - The LED flashes rapidly in blue for 2 seconds.
- Release the **P** button. **All radio codes have been deleted.**

NOTE:

If the **P** button is released prematurely, the device reset will be aborted and the radio codes are not deleted.

5 Description of S5/S7 Scan

The factory code must be changed for the initial start-up of the finger scanner! For this, see the included operating instructions from GU/BKS.

6 Inspection and Maintenance

6.1 Checking the seating and sealing

Before finishing the fitting process, check that the aluminium entrance door has been fitted correctly.

- Inspect the following points:
 - Seating of the fastening screws to the building structure
 - Sealing of the aluminium entrance door to the building structure



Tab. 1: Classification of the resistance classes of break-in-resistant components for solid walls

Resistance class of the component acc. to DIN EN 1627	Surrounding walls					
	In brickwork according to DIN 1053-1				Reinforced concrete walls acc. to DIN 1045	
	Wall thickness (unplastered)	Compression strength class of the bricks (DFK)	Apparent density class of the bricks (RDK)	Mortar group	Nominal thickness	Strength class
RC 2	≥ 115 mm	≥ 12	–	min. MG II/DM	min. 100 mm	min. B 15
RC 3					min. 120 mm	
RC 4					min. 140 mm	

Tab. 2: Classification of the resistance classes of break-in-resistant components for gas concrete walls

Gas concrete wall			
Resistance class	Compression strength class of the bricks	Nominal thickness	Version
RC 2	≥ 4	≥ 170 mm	Bonded
RC 3		≥ 240 mm	

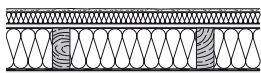
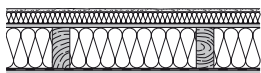
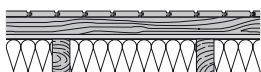
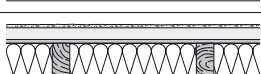
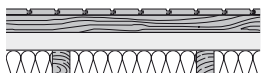
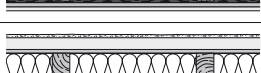
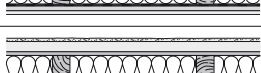
Tab. 3: Classification of the resistance classes of break-in-resistant components for timber panel walls

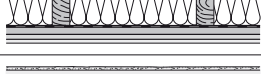
Resistance class	Suitable wall construction
RC 2	 Plaster with fabric, polystyrene 40 mm, gypsum fibre board 15.0 mm, timber post 60/140, MF 140 mm, PE plastic film, gypsum fibre board 15 mm
	 Plaster with fabric, polystyrene 40 mm, OSB 12.0 mm, timber post 60/140, MF 140 mm, PE plastic film, OSB 12.0 mm, GKB 12.5 mm
	 Tongue + groove timber cladding 19×120 mm, batten 40×60 mm, DHF (permeable moisture resistant wood fibre board) 15 mm, timber post 60/140, MF 140 mm, PE plastic film, OSB 15.0 mm, GKB 12.5 mm
	 Plaster with fabric, SB W 40 mm, DWD (permeable wall and roof panel) 15.0 mm, timber post 60/140, MF 140 mm, PE plastic film, FP (plywood) 16.0 mm, V100 E1, GKB 12.5 mm
RC 3	 Tongue + groove timber cladding 19×120 mm, batten 40×60 mm, SB.W 60 mm, timber post 60/140, MF 140 mm, PE plastic film, OSB 15.0 mm, GKB 12.5 mm
	 Plaster with fabric, SB W 40 mm, DWD 15.0 mm, timber post 60/140, MF 140 mm, kraft paper, BFU 15.0 mm, GKB 12.5 mm
	 Plaster with fabric, approx. 4 mm, PS 30 mm, FP 13 mm V100E1, timber post 60/140, MF 140 mm, PE plastic film 0.2 mm, FP 13 mm V20E1, batten 40×60 mm/insulation MF 40 mm, BFU 15.0 mm, GKB 9.5 mm
RC 4	 Plaster with fabric, approx. 4 mm, SB W 60 mm, DWD 15.0 mm, timber post 60/160, MF 160 mm, sodium kraft paper, OSB 22 mm, BFU 15.0 mm, GKB 12.5 mm
	 Plaster with fabric, approx. 4 mm, SB W 60 mm, DWD 15.0 mm, timber post 60/160, MF 160 mm, sodium kraft paper, FP 13 mm V20, steel sheet 0.75 mm, FP 13 mm V20, GKB 9.5 mm

Prefabricated and timber partition walls with respective resistance class suitability certification from the manufacturer.

7 Cleaning and Care

7.1 Surface

You have purchased a high - grade aluminium product. Protect it by performing cleaning and upkeep regularly. This is the only way to prevent undesired corrosion caused by environmental conditions and contamination related to use.

Wash surfaces with a mixture of alcohol and water before bonding.

ATTENTION

Unsuitable care products

The door surface and adjacent components can be damaged by aggressive, corrosive or abrasive materials such as acids or steel brushes.

- ▶ Only use conventional care products and microfibre cloths to maintain the aluminium entrance door.
- ▶ Use water to rinse any dirt off high-gloss surfaces.
- ▶ Never use polish on matt surfaces.
- ▶ Always take note of the manufacturer information for the care products.

- ▶ **Oil or lubricate** moveable fitting parts **once per year**. Only use acid-free oil or vaseline. The door hinges are maintenance-free.

7.2 Cylinder

To maintain the closing cylinder, only special cylinder care spray is approved. Do not use products that contain graphite under any circumstances.

8 Dismantling and Disposal

Dismantling of the aluminium entrance door is conducted in the reverse order of the assembly.

To dispose of it properly after dismantling, the aluminium door must be disassembled into its individual components and disposed of according to local official regulations.

9 Spare Parts

We advise explicitly that only genuine spare parts are tested and approved.

The following cylinders may be used in conjunction with our locks H5 / H9 / S5 / S7:

- Knob cylinders
- Cylinders with/without compensator function
- Cylinders with/without emergency and hazard function

If using other locks, such as gear locks with anti-panic function, proper function in conjunction with the desired cylinder must be checked and ensured in advance.

10 Declaration of conformity

(as defined in the EC Construction Products Directive 89/106/EEC)

Manufacturer: Hörmann KG Verkaufsgesellschaft
Upheider Weg 94-98
33803 Steinhagen, Germany

The product type:

Aluminium entrance door: ThermoSafe, ThermoCarbon

is developed, designed and manufactured in accordance with the EU Construction Products Regulation 305/2011

Applied and consulted standards:

EN 14351-1: 2006 windows and doors – product standard, performance characteristics – „Windows and exterior doors without characteristics related to fire protection and/ or smoke-tightness“

Any modification made to this product without our express permission and approval shall render this declaration null and void.

Steinhagen, Germany, 01.07.2013



ppa. Axel Becker, Management

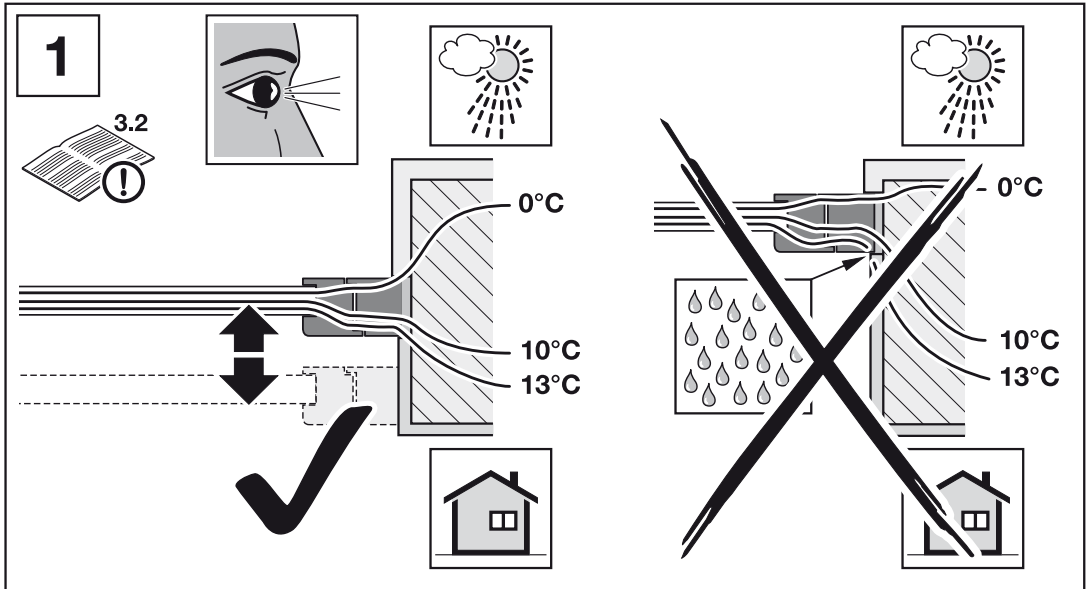

1a

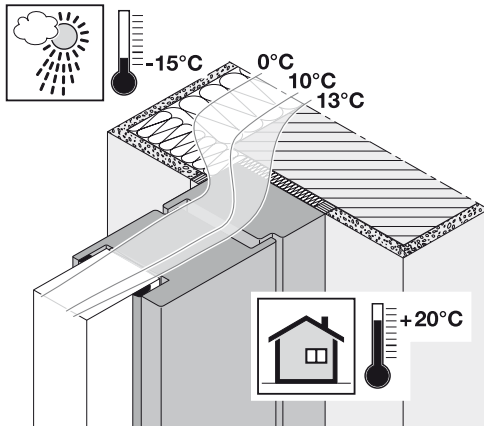

1b

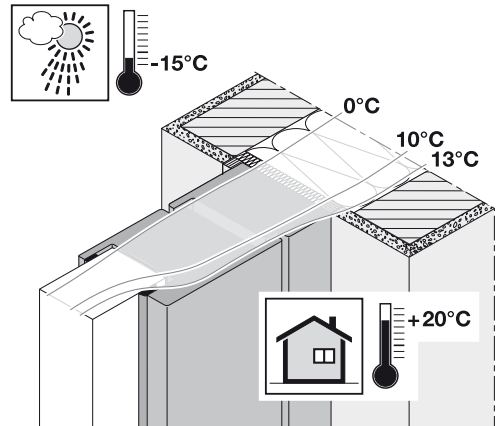

1c

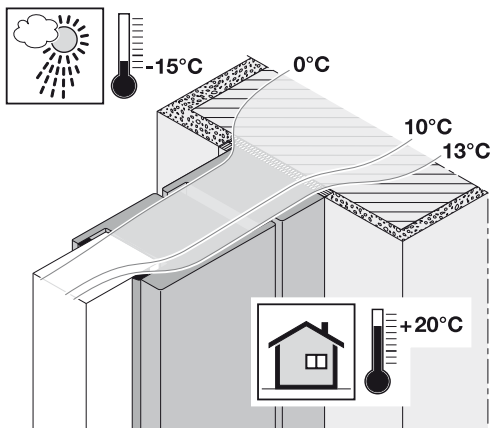

1d

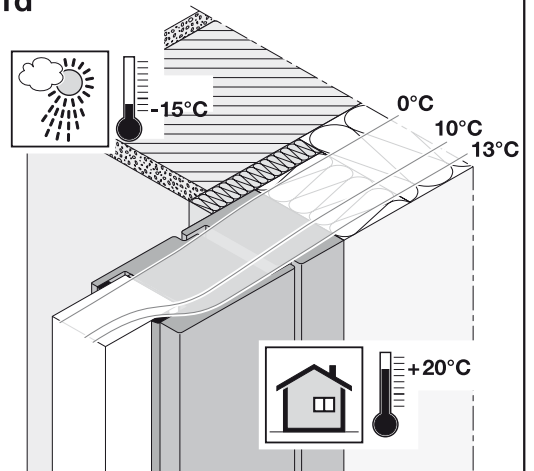

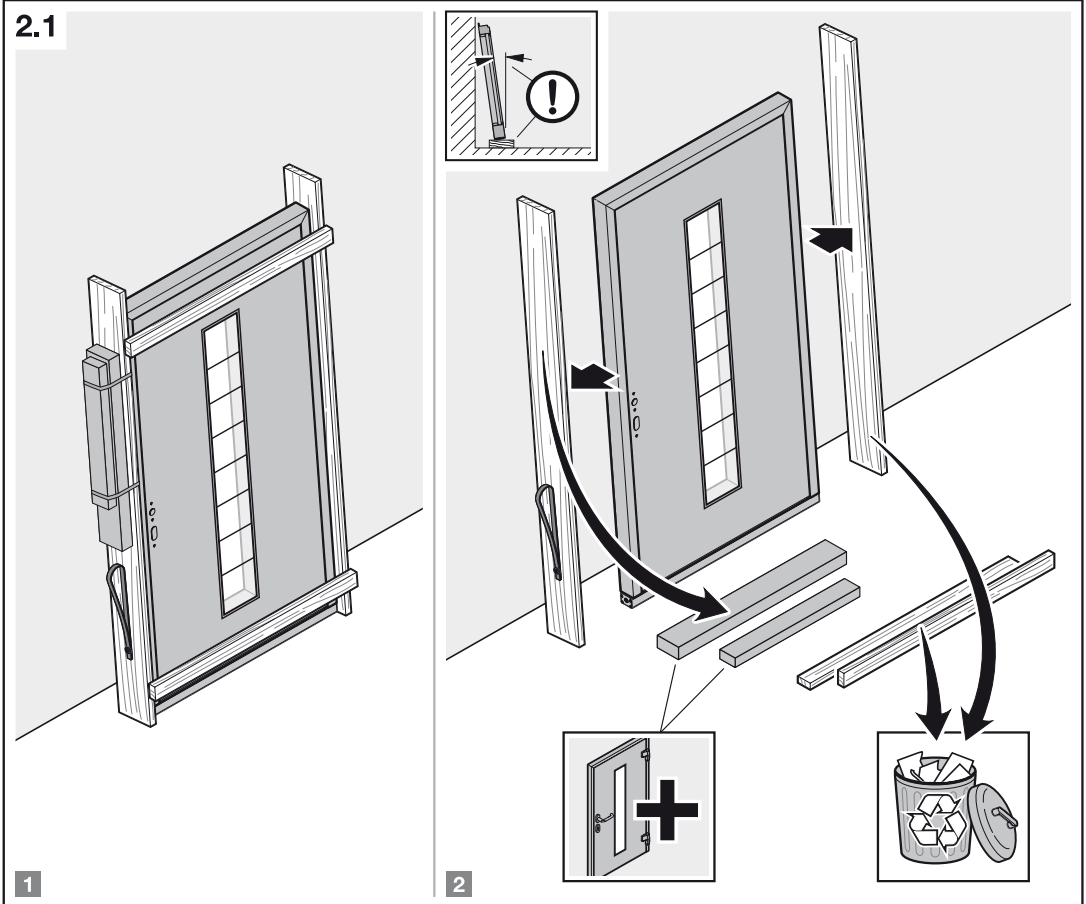
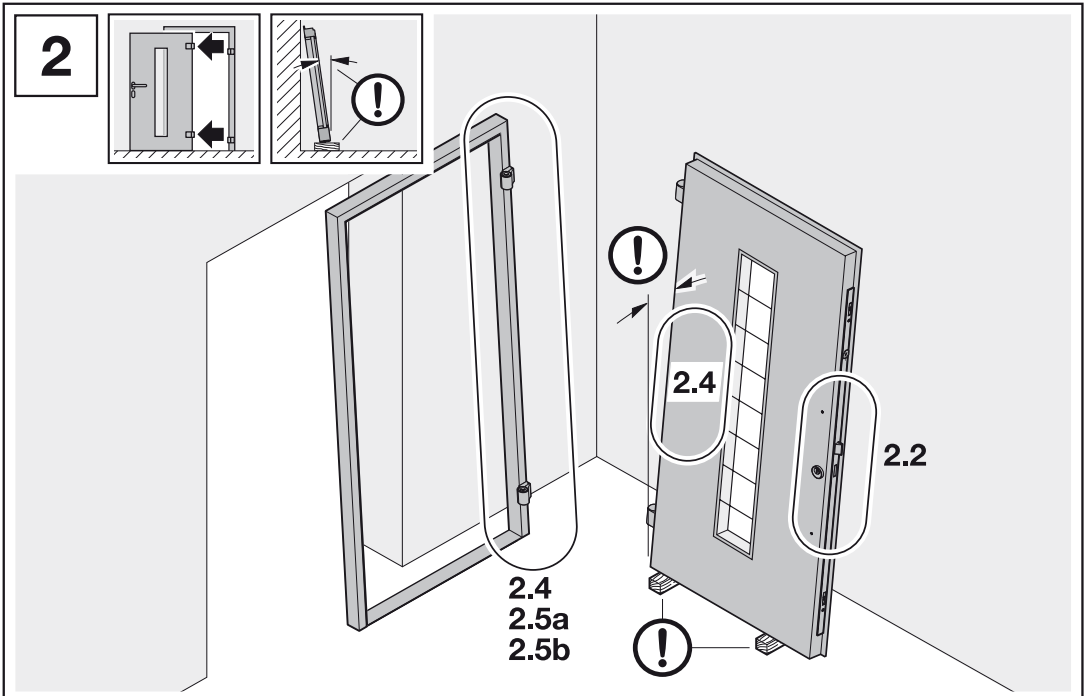

2.2a

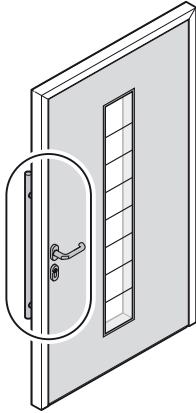
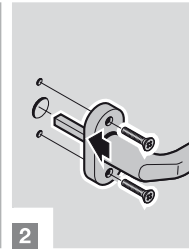
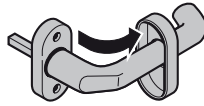

1

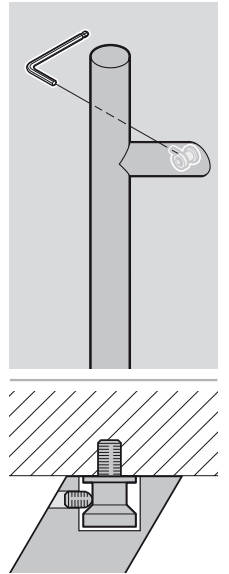
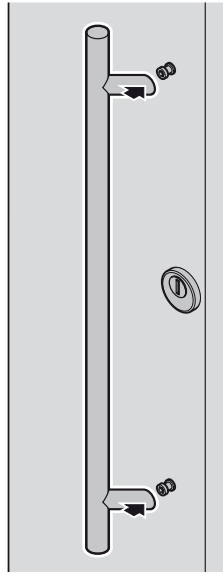
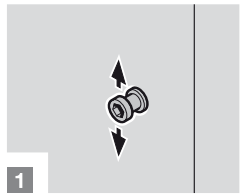
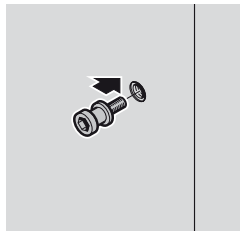
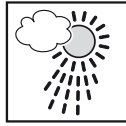

1

2

2.2b

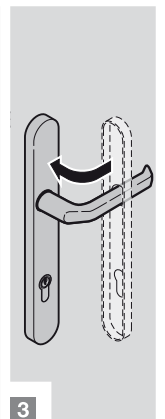
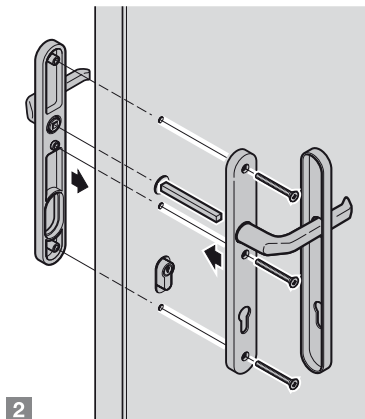
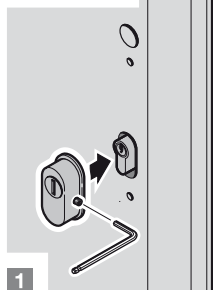
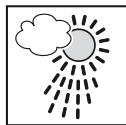
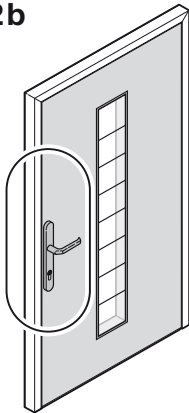

1

2

3

2.3

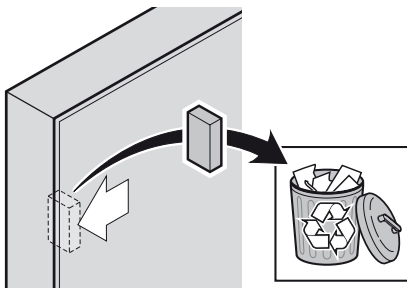
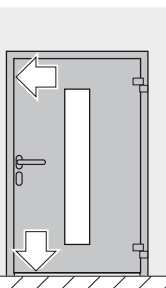

2.4

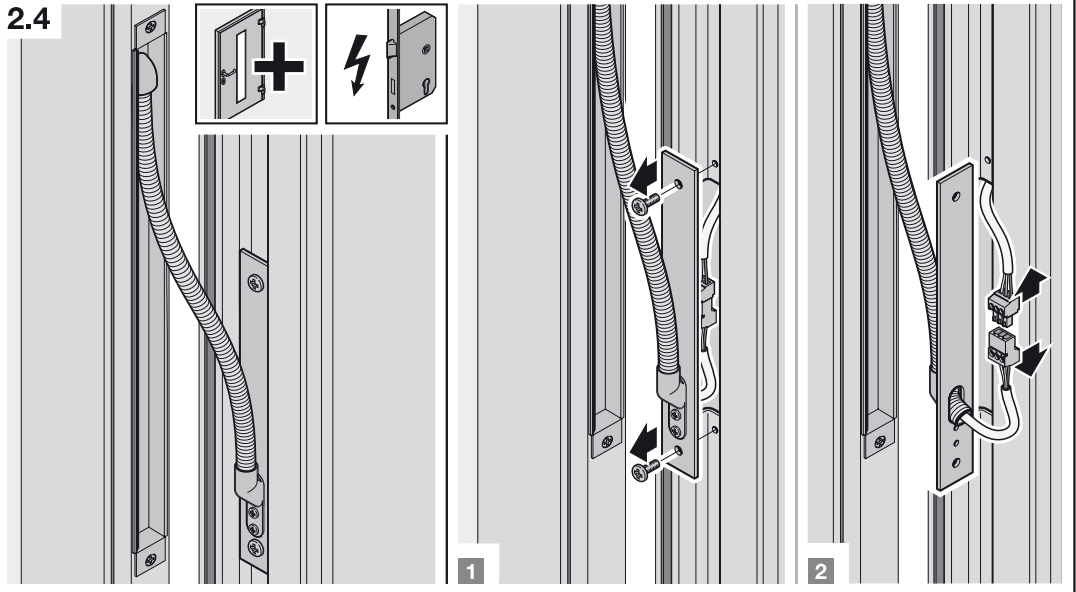

2.5a

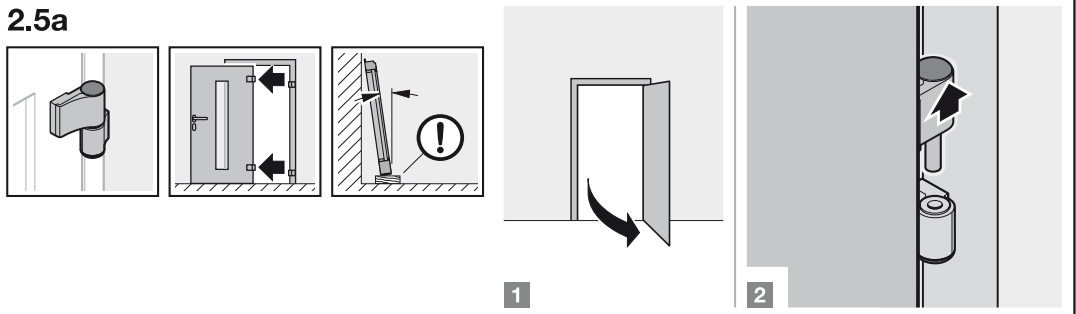

2.5b

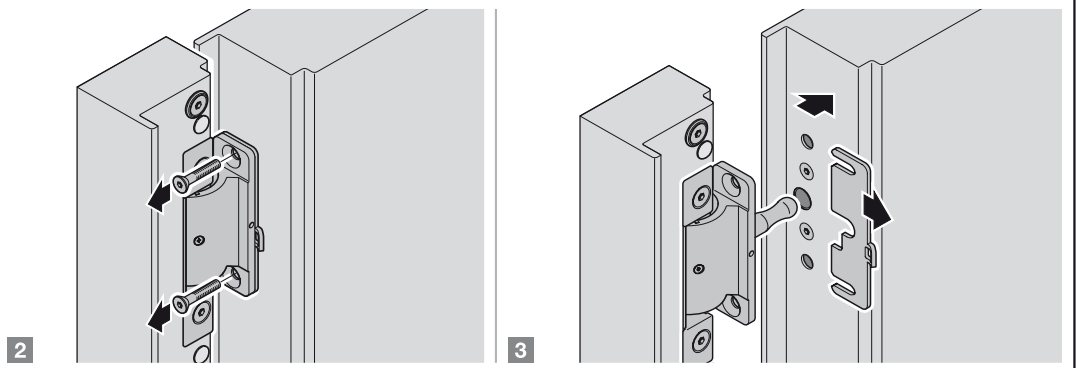
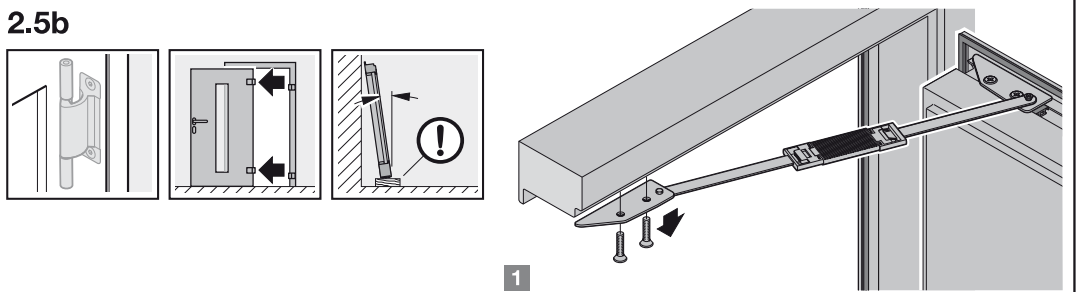

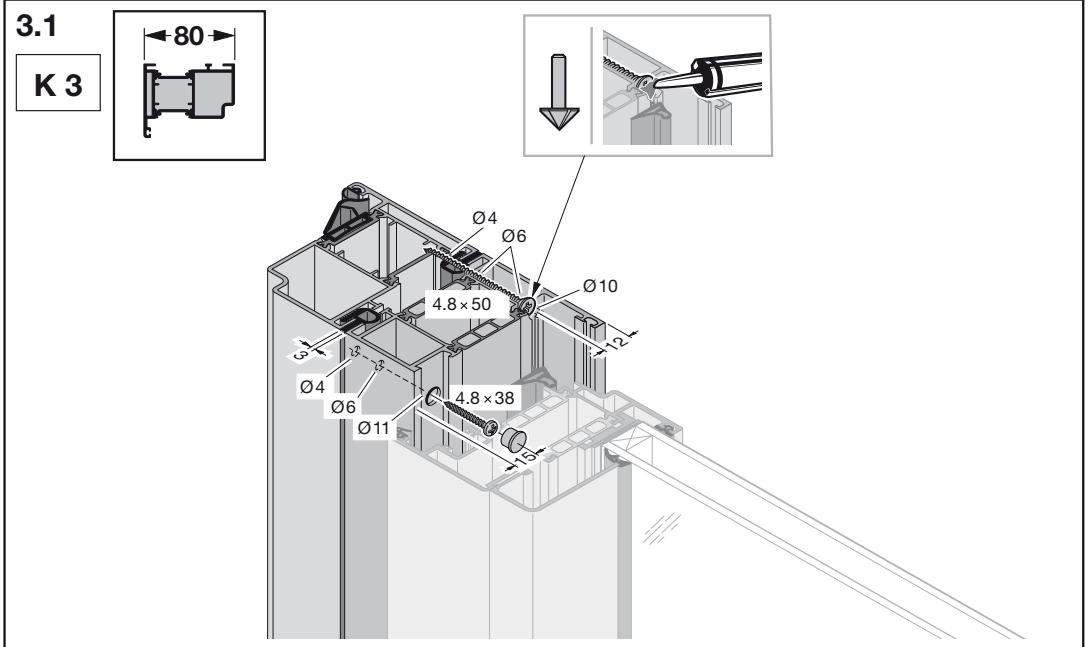
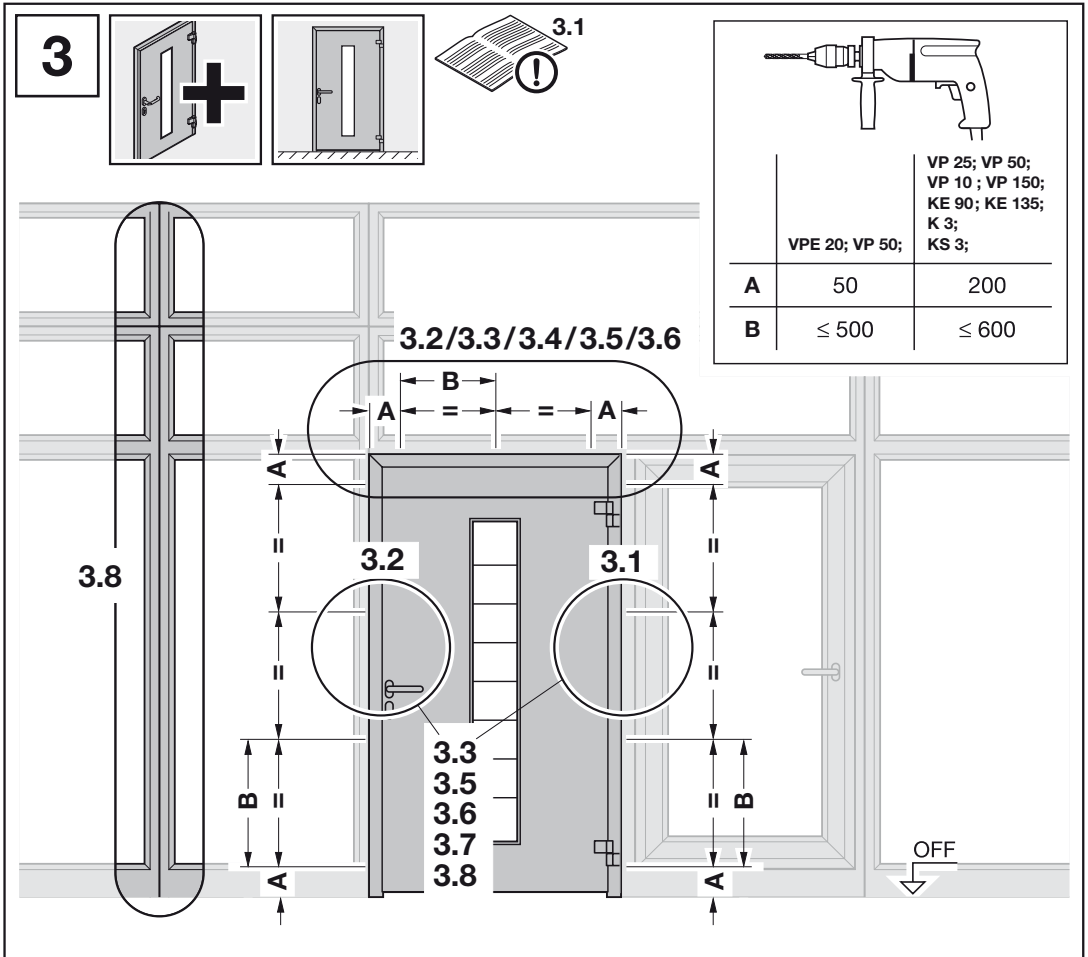

3.2a

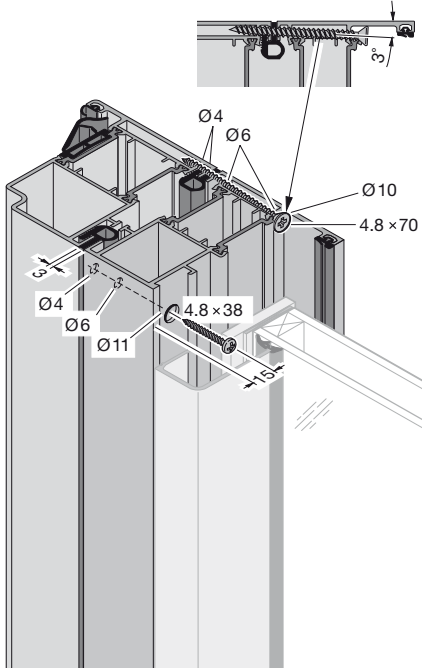
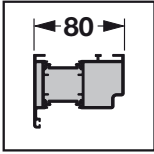

3.2a

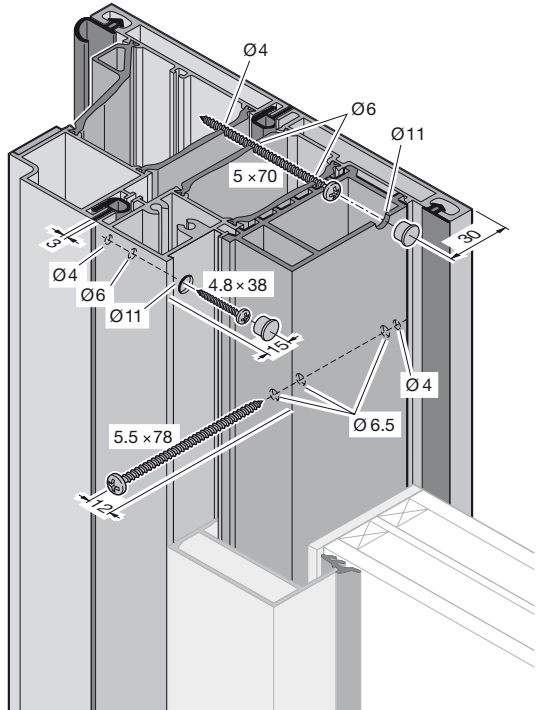
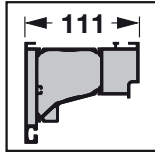

3.3

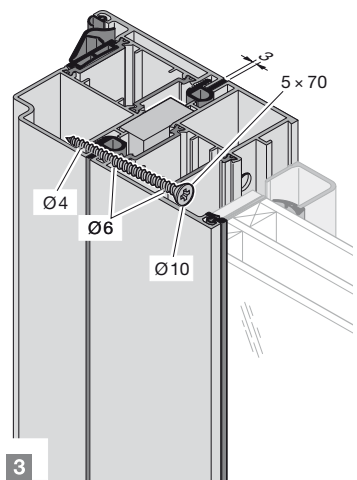
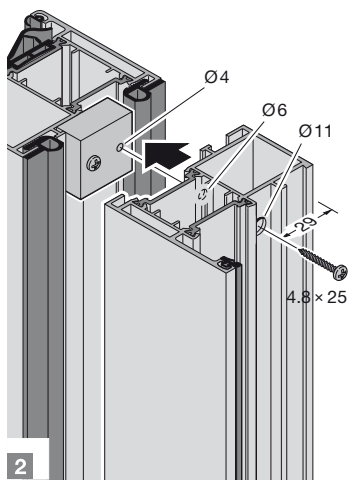
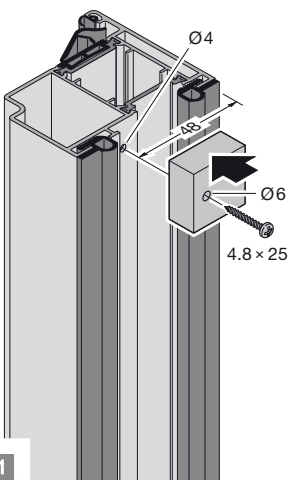
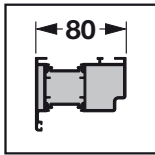

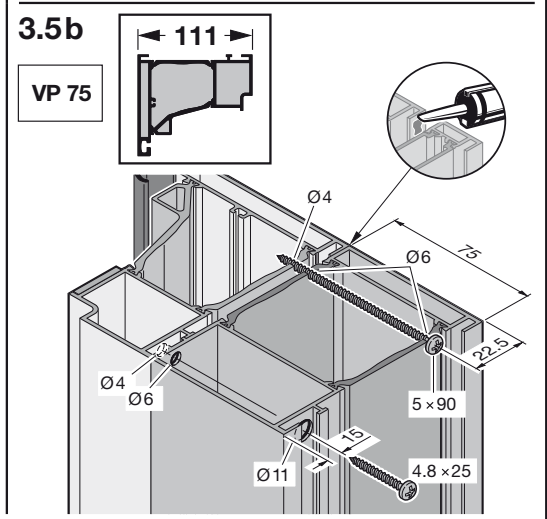
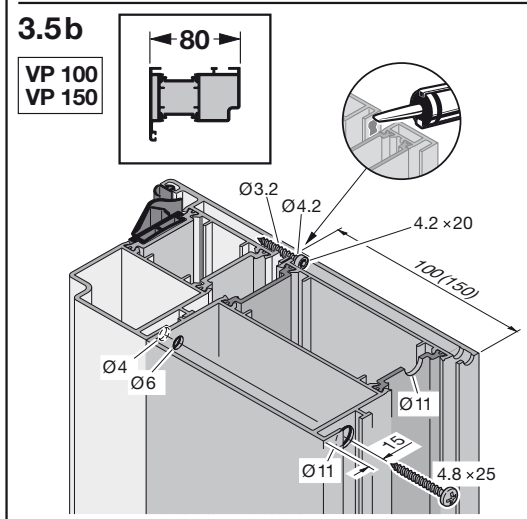
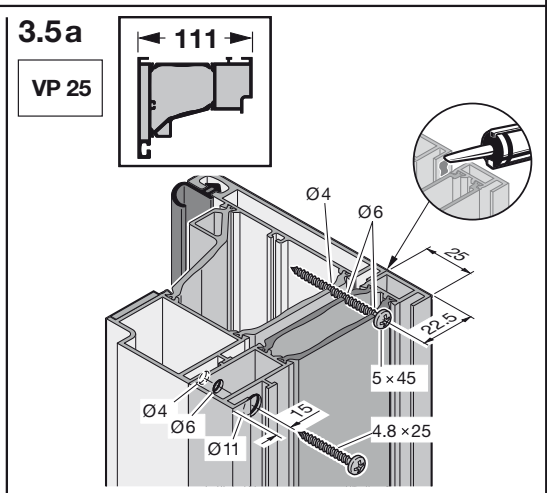
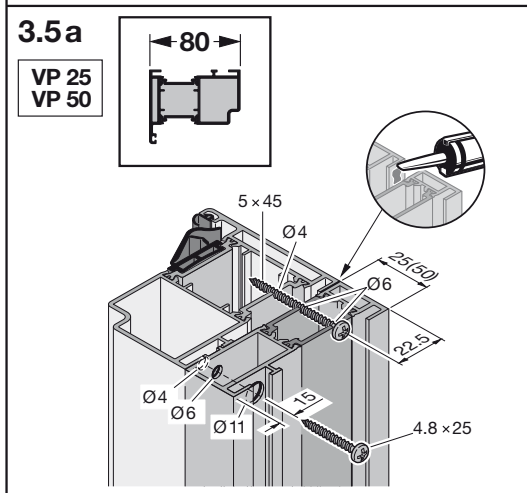
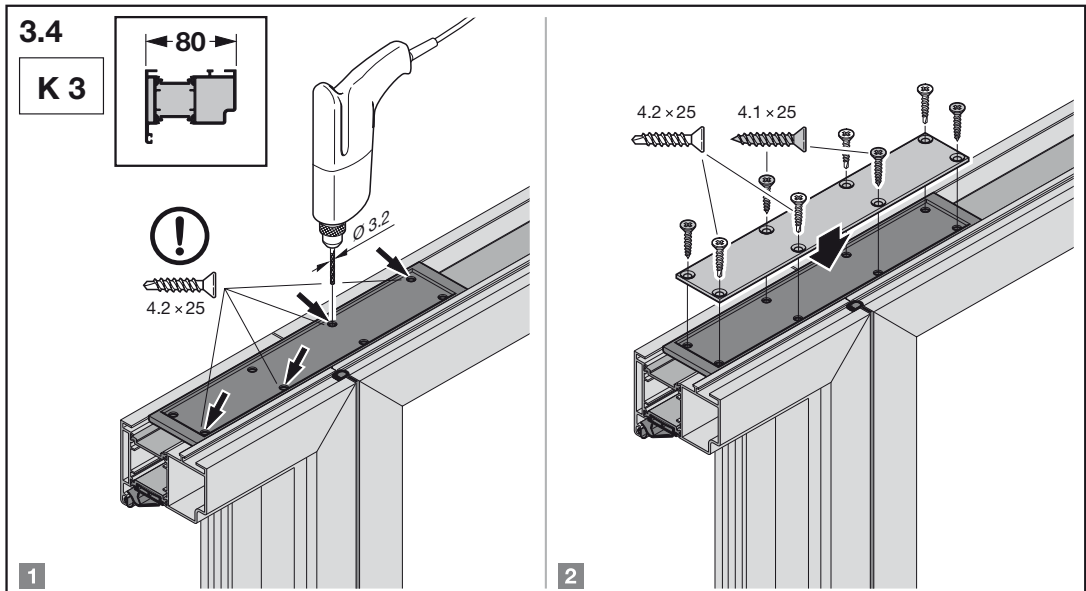

3.6

VPE 20
VPE 50

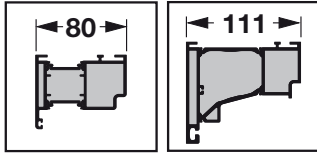

1

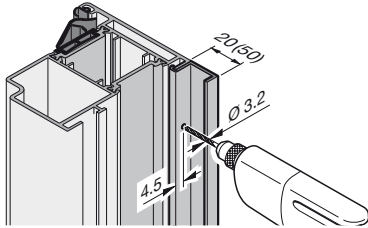

2

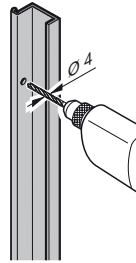

3

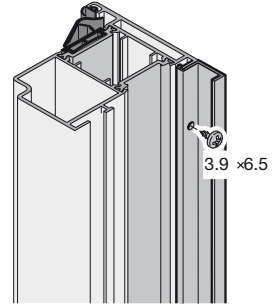

3.7a

KE 135

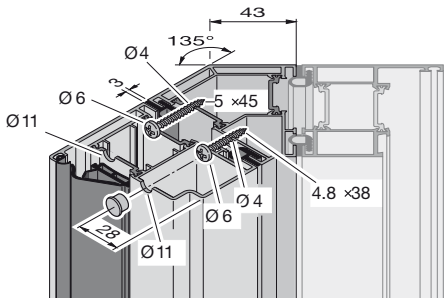
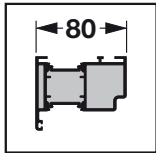

3.7b

KE 90

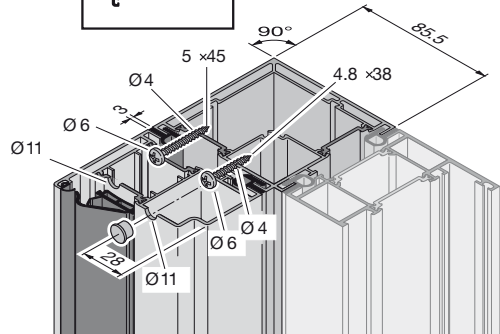
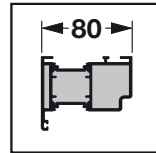

3.8

KS 3

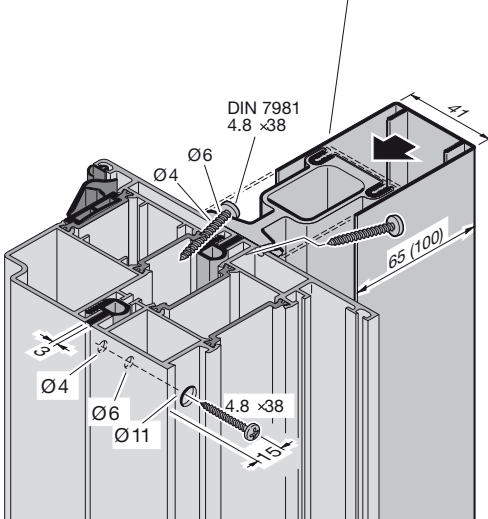
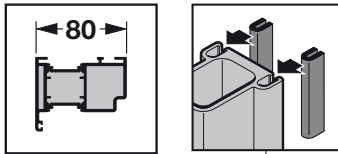

3.8

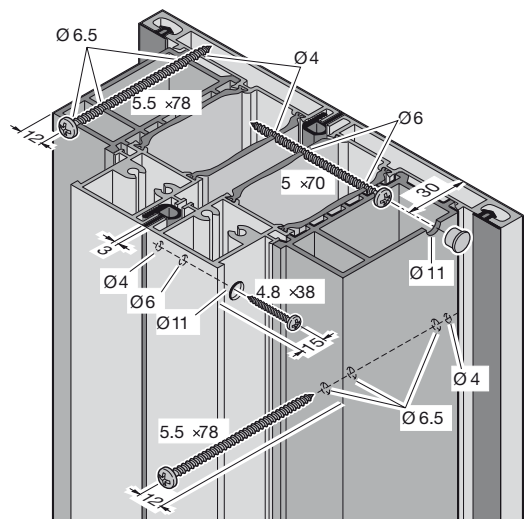
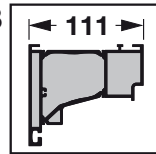

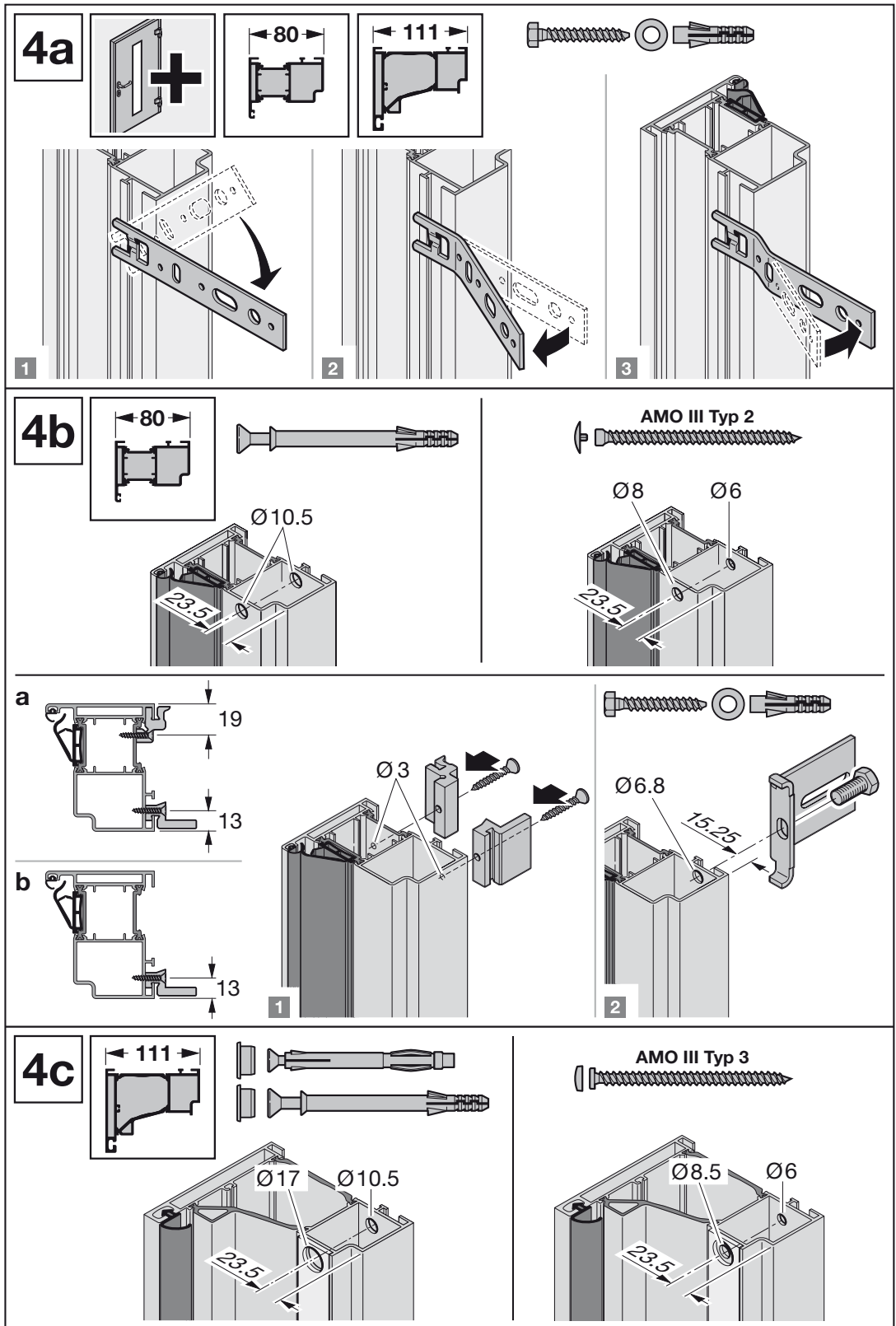

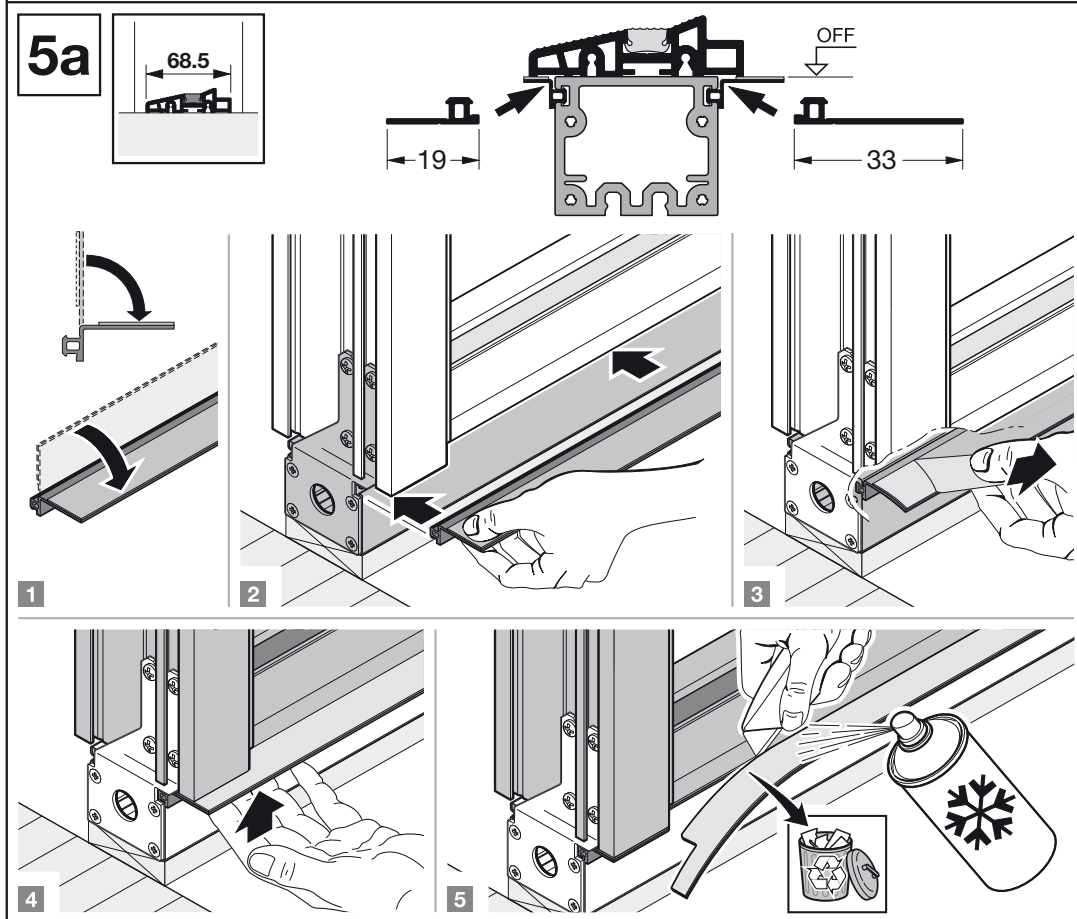
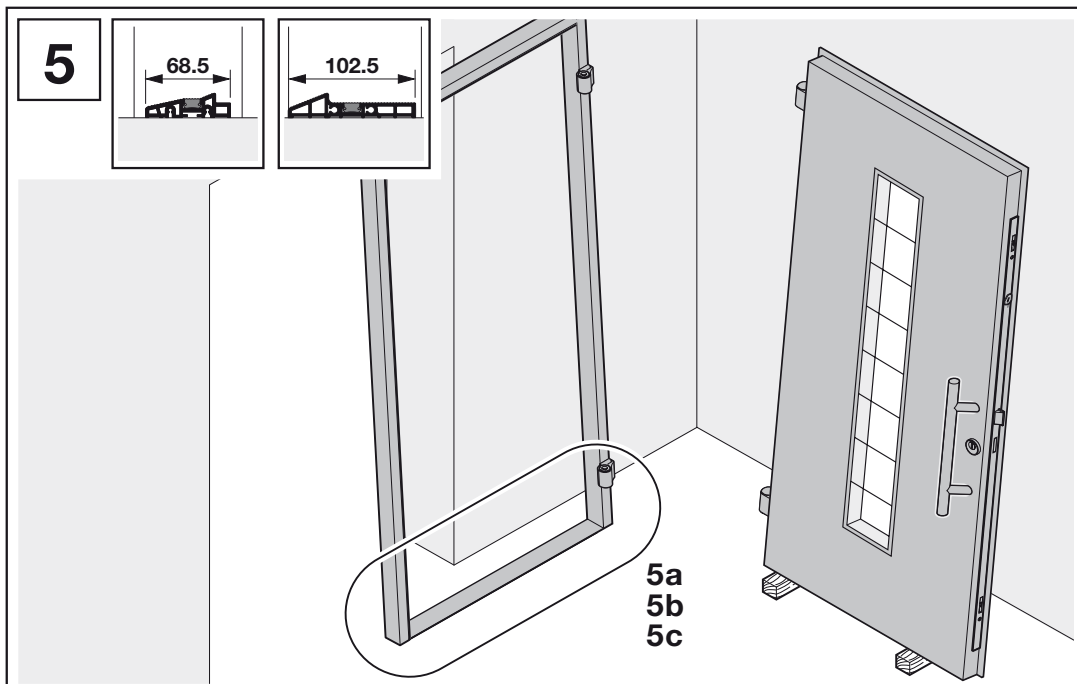

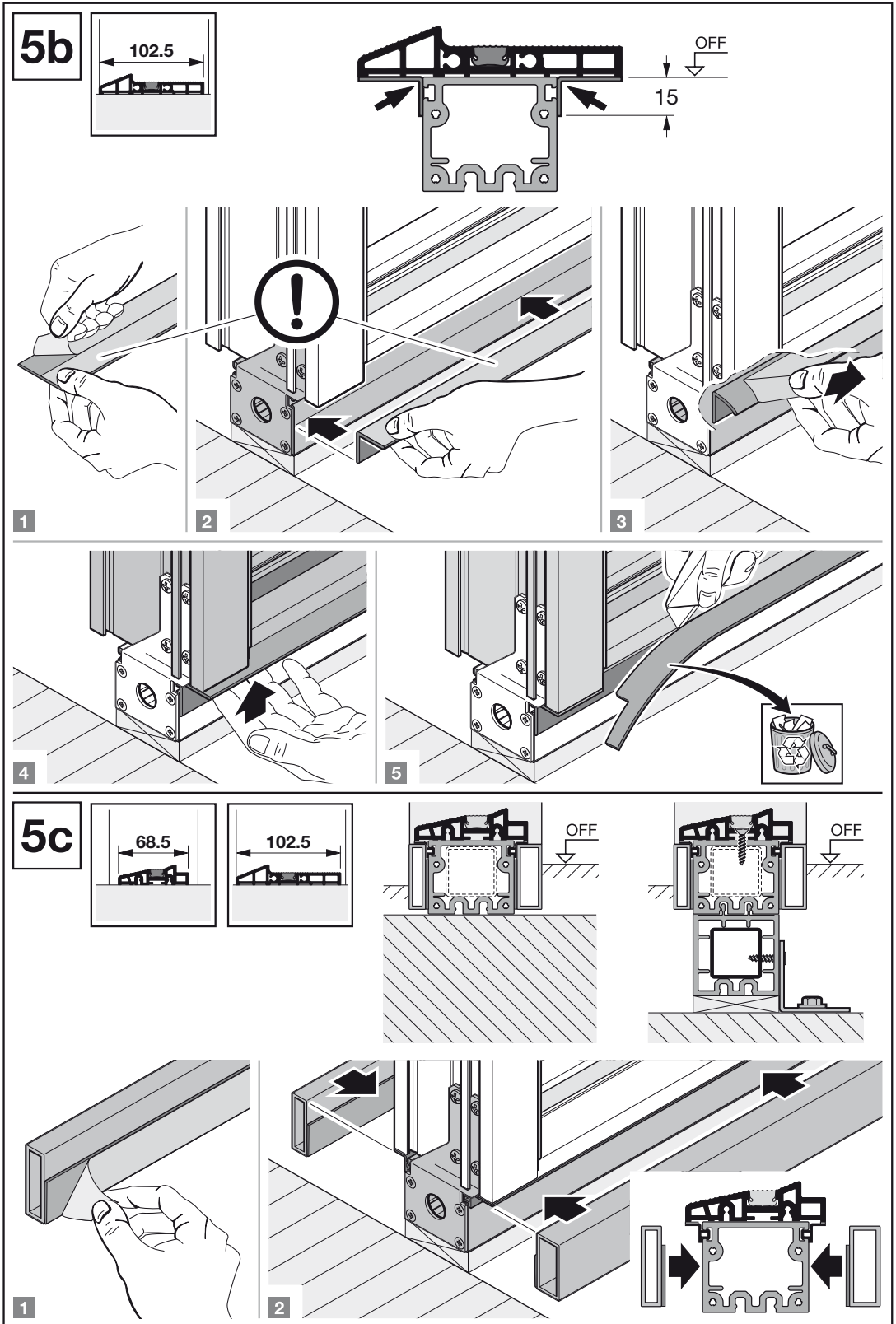

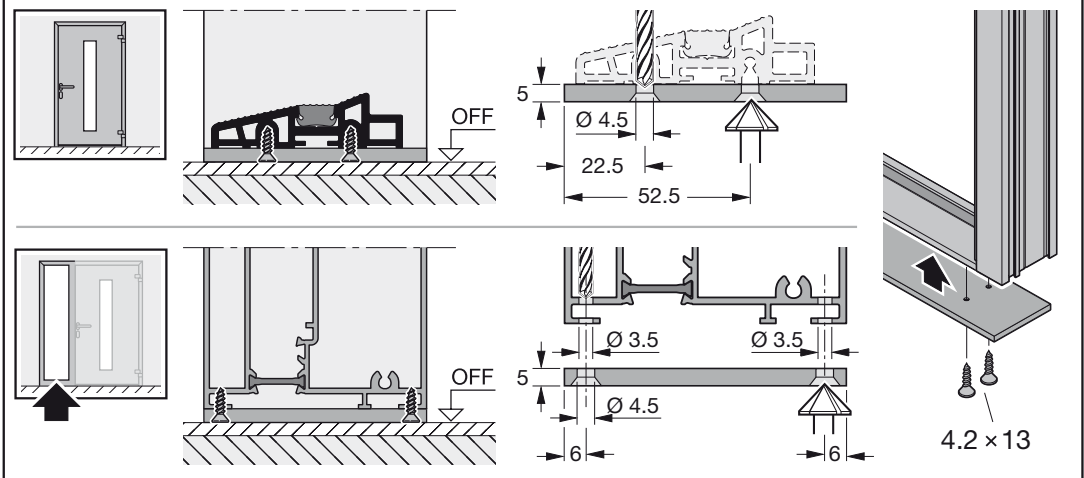
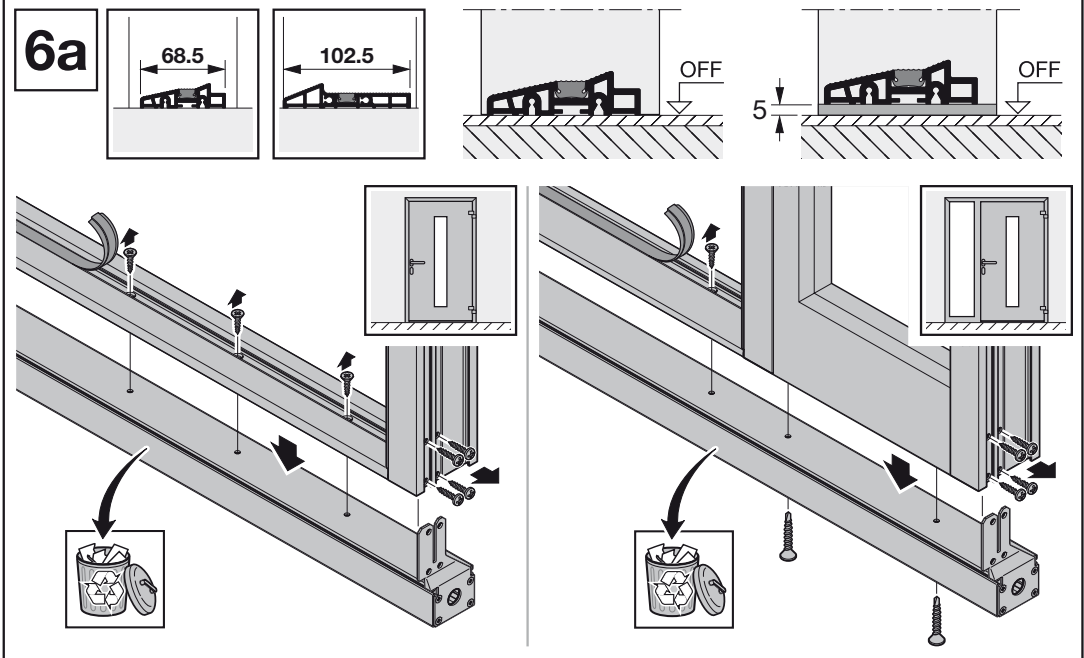
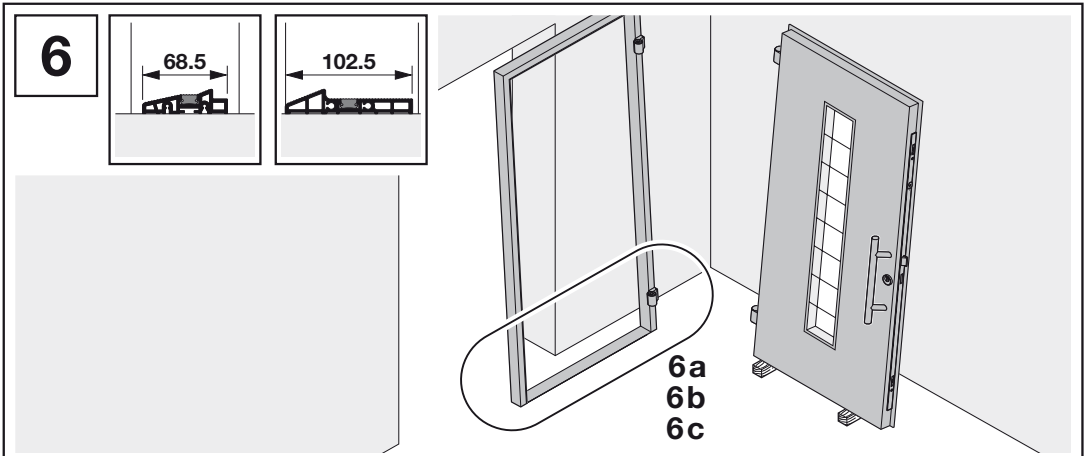

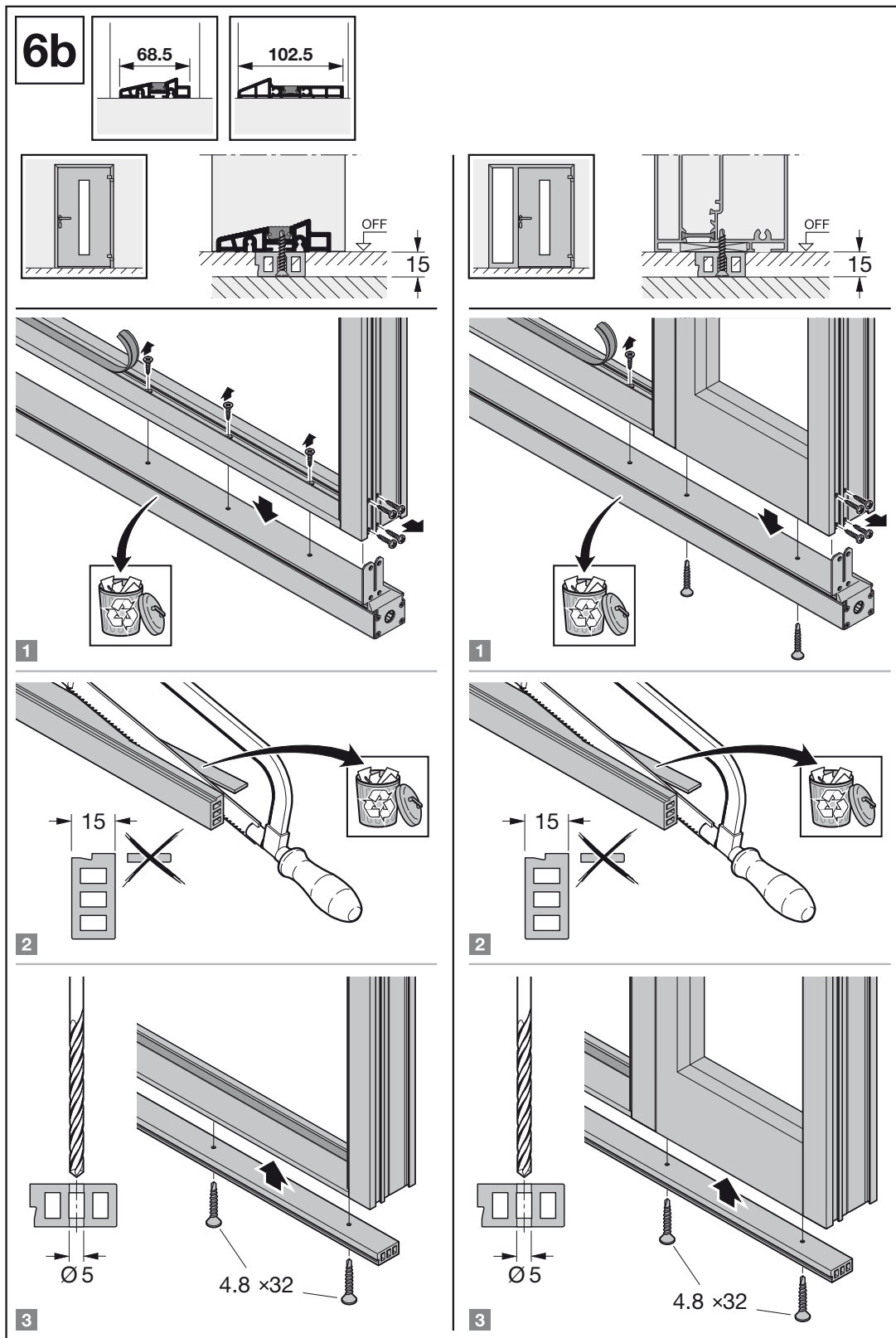

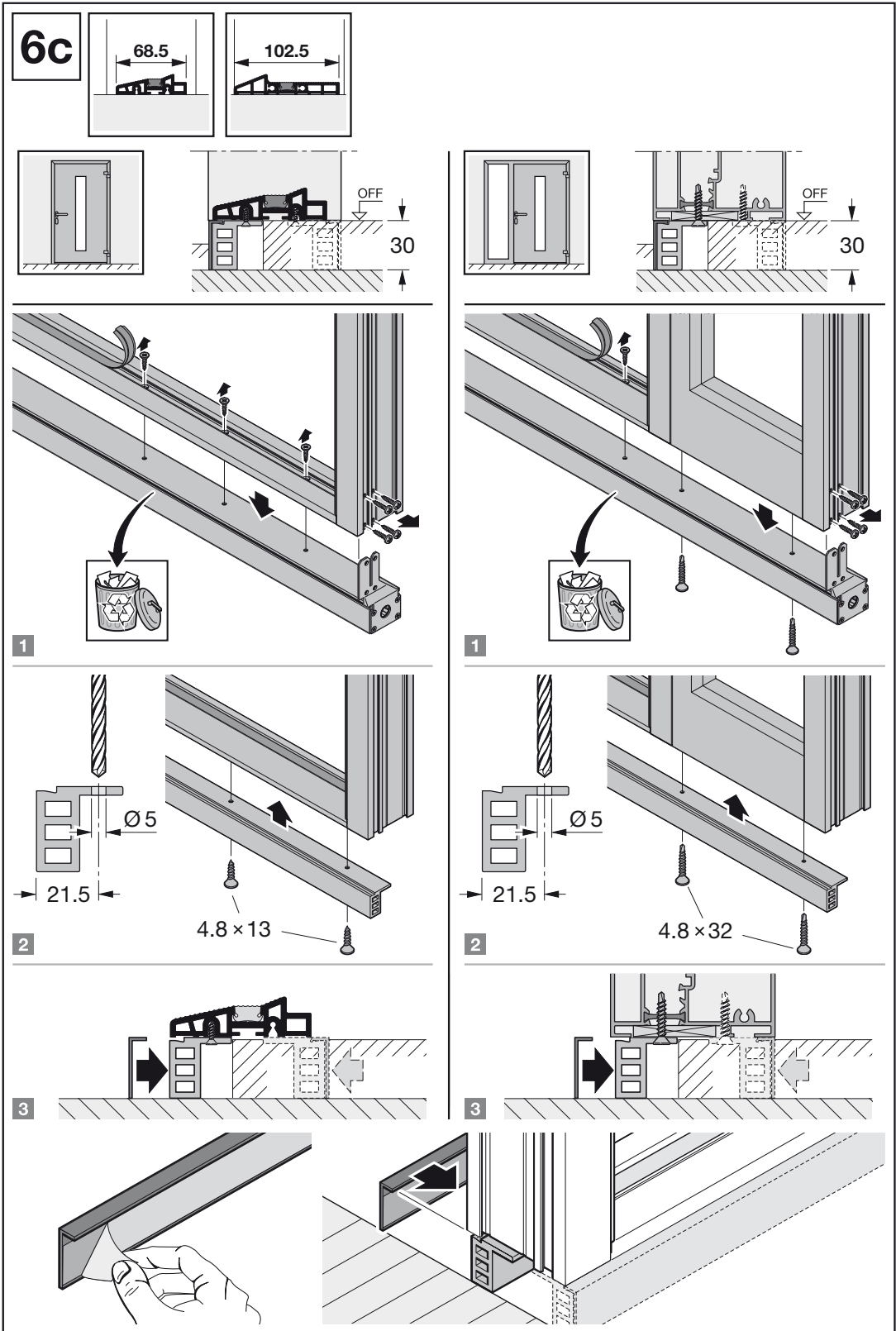

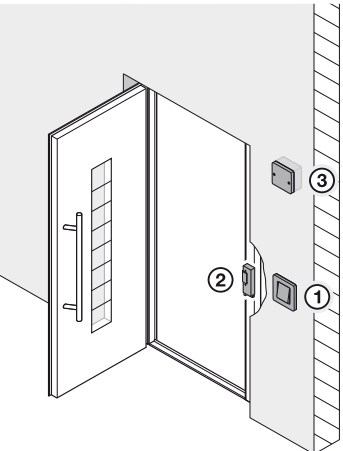

7a







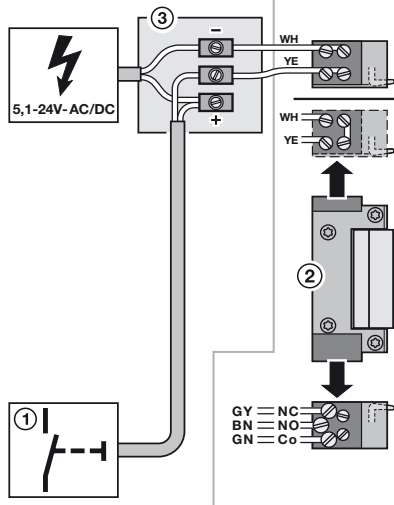

5,1-24V-AC/DC

WH
YE

WH
YE

GY = NC
BN = NO
GN = Co

V-AC/DC	Amp.	
5,1 - 6,9	0,5	∞
6 - 12	0,5 - 1	< 1 min
10,2 - 13,8	0,3	∞
12 - 24	0,3 - 0,5	< 1 min

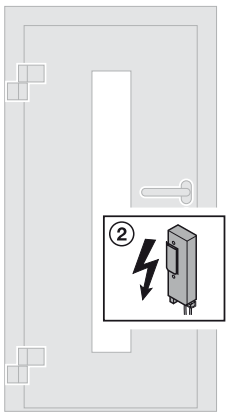

E-Öffner

7b

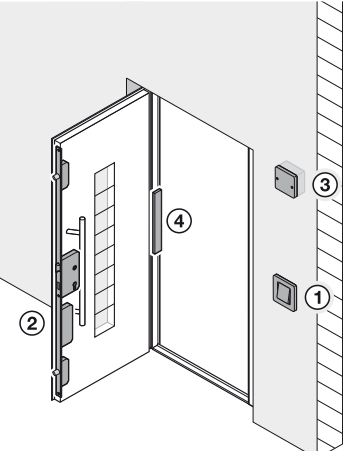





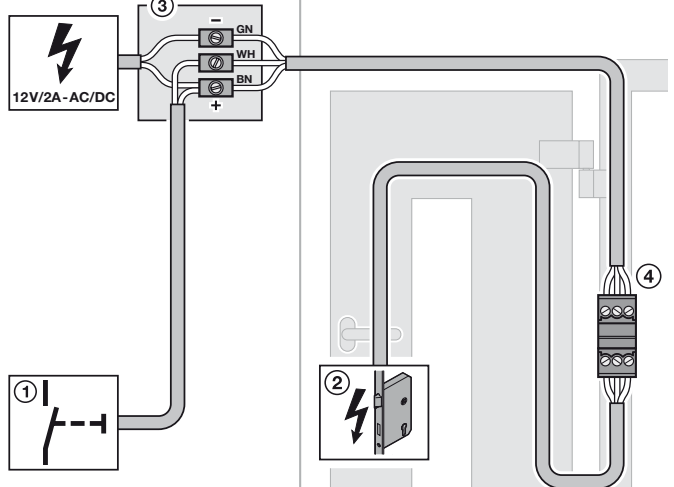

12V/2A-AC/DC

GN
WH
BN

V-AC/DC	Amp.	
5,1 - 6,9	0,5	∞
6 - 12	0,5 - 1	< 1 min
10,2 - 13,8	0,3	∞
12 - 24	0,3 - 0,5	< 1 min

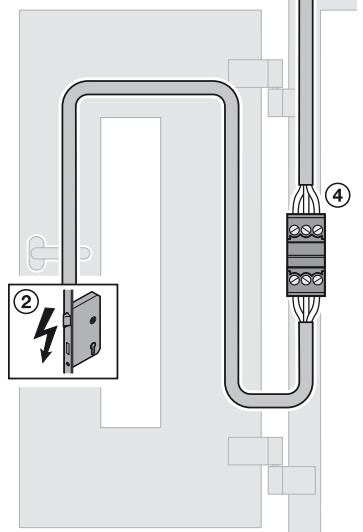

S5 ThermoSafe Comfort

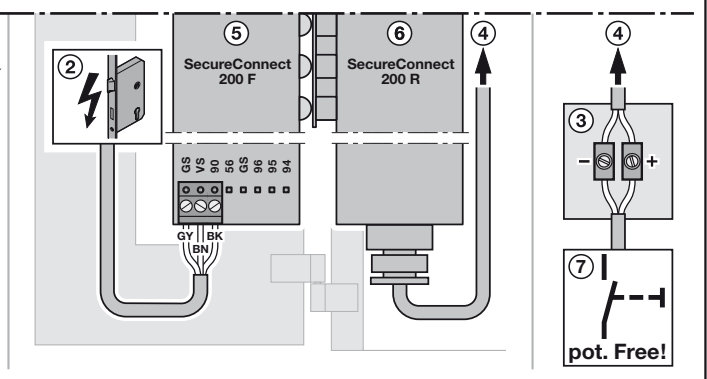
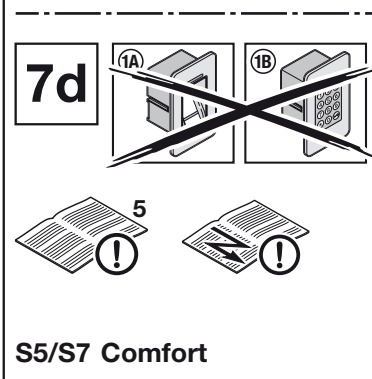
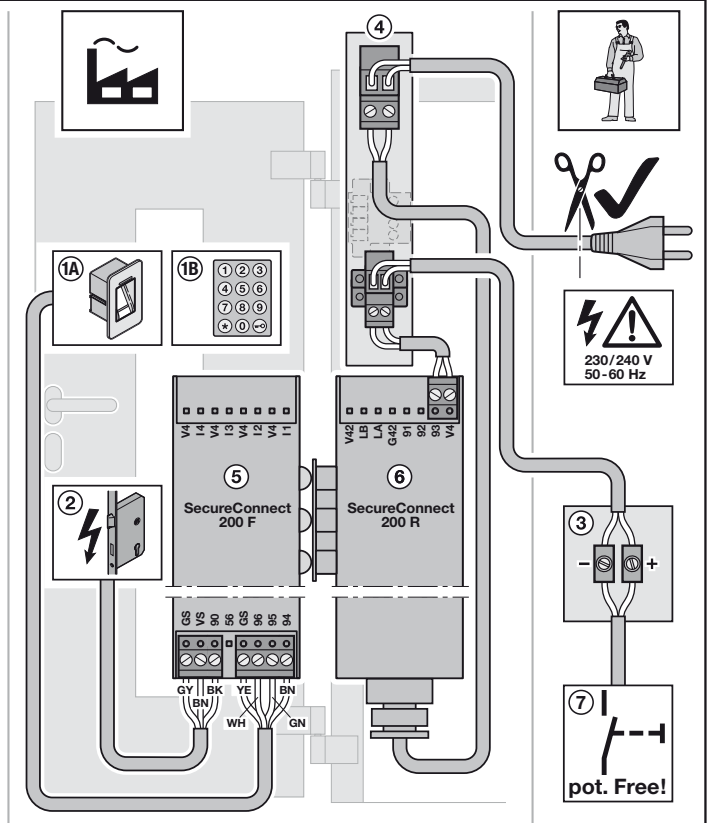
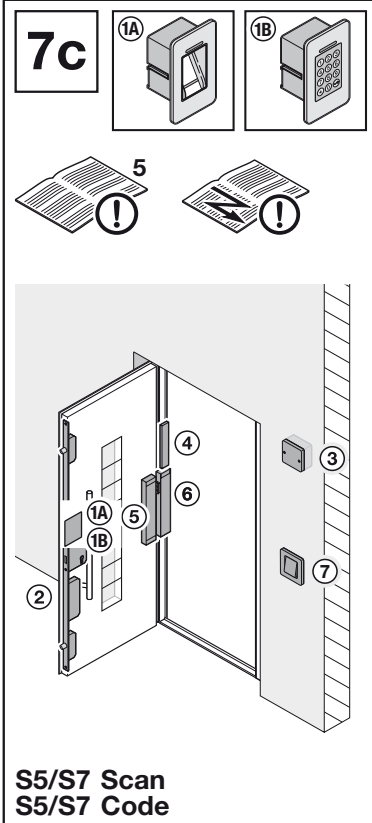
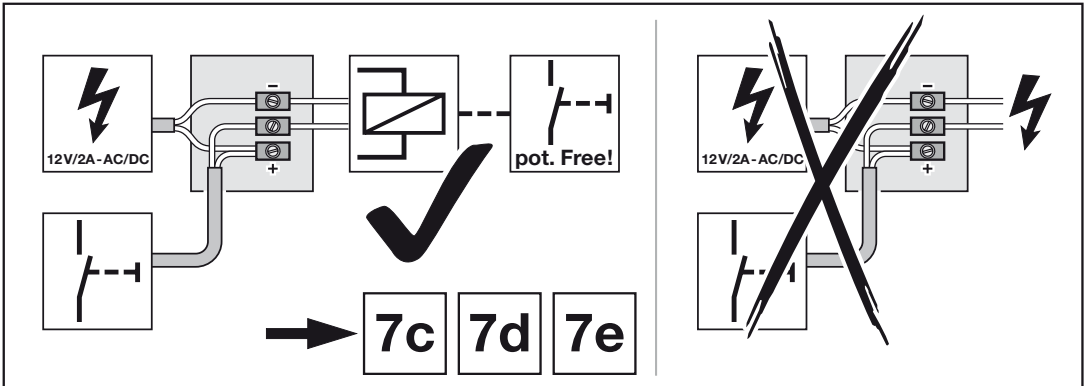

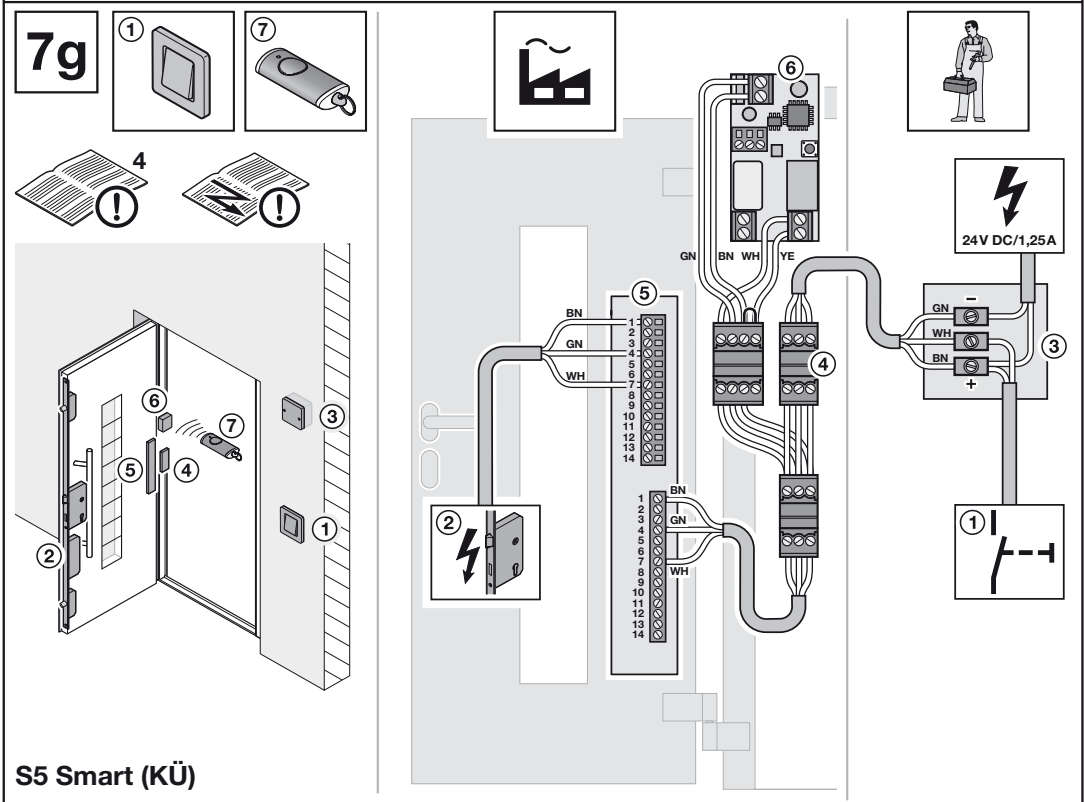
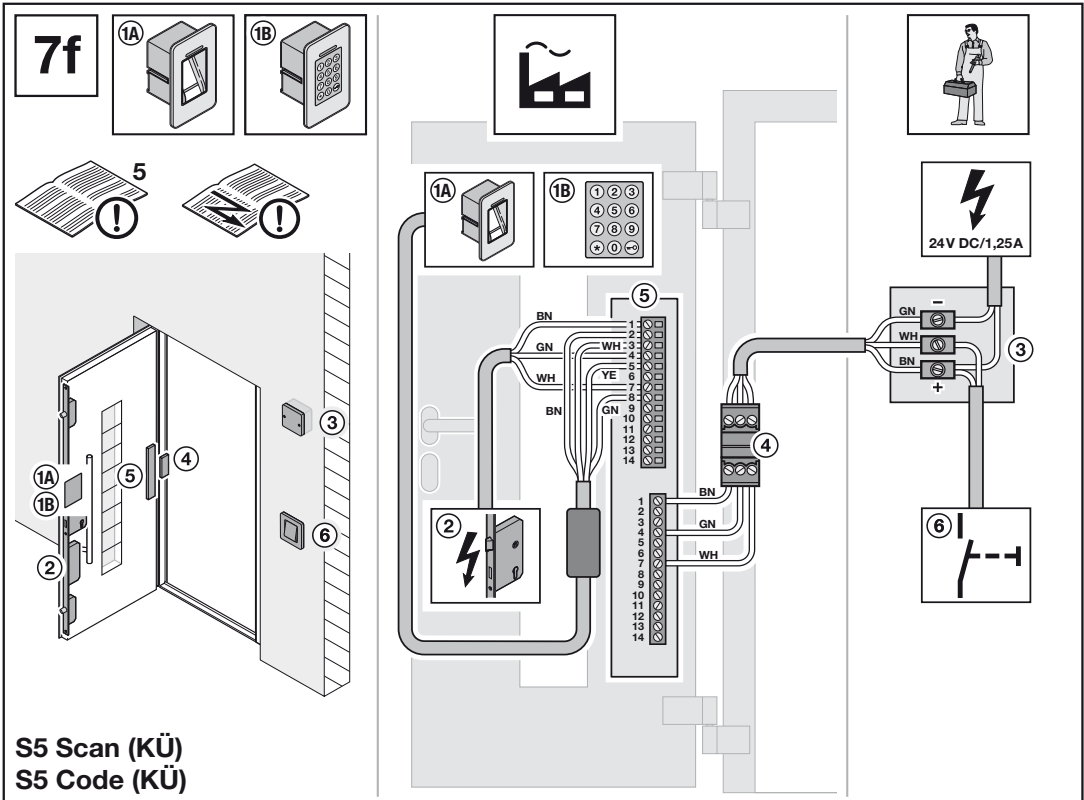

8a

S5/S7 Ecturn

8b

S5/S7 Ecturn Smart

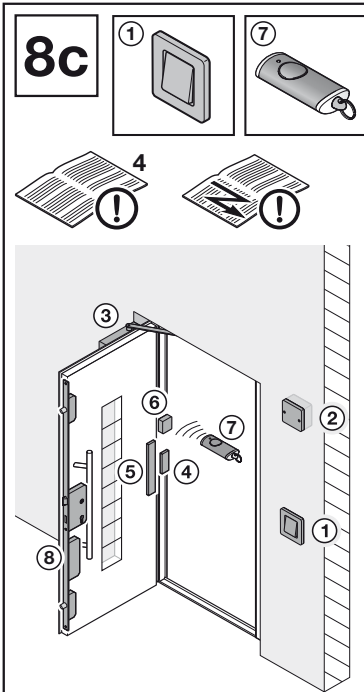

S5 Ecturn Smart (KÜ)

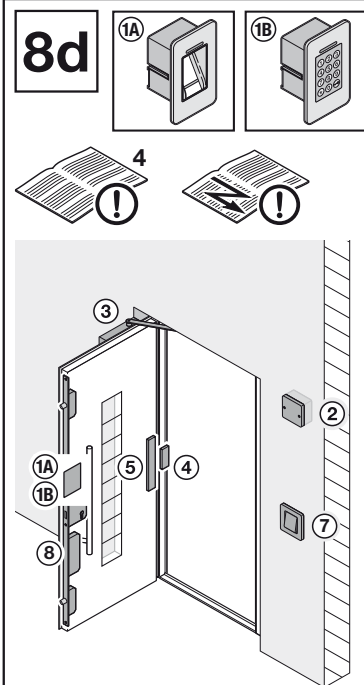
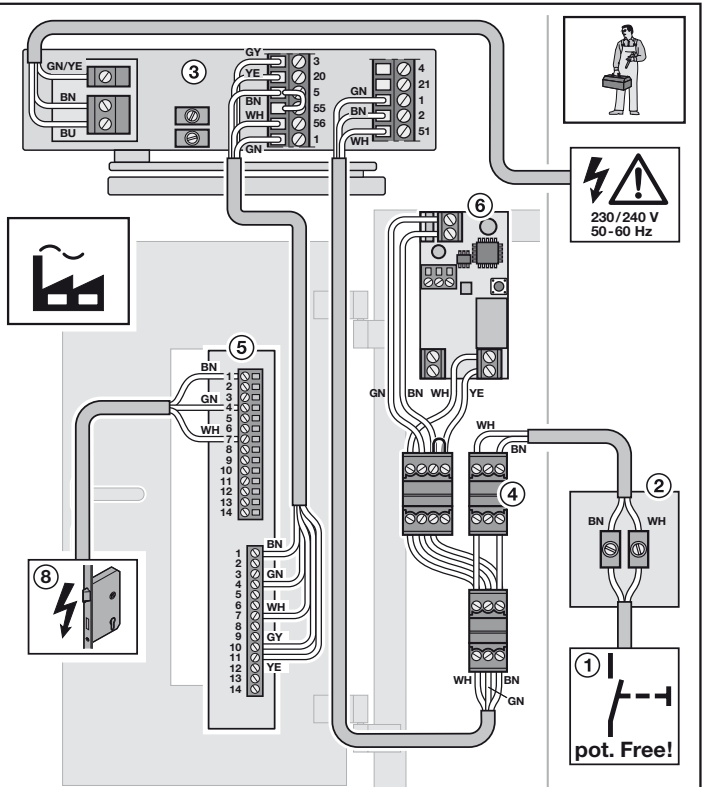

S5 Ecturn Scan /Code (KÜ)

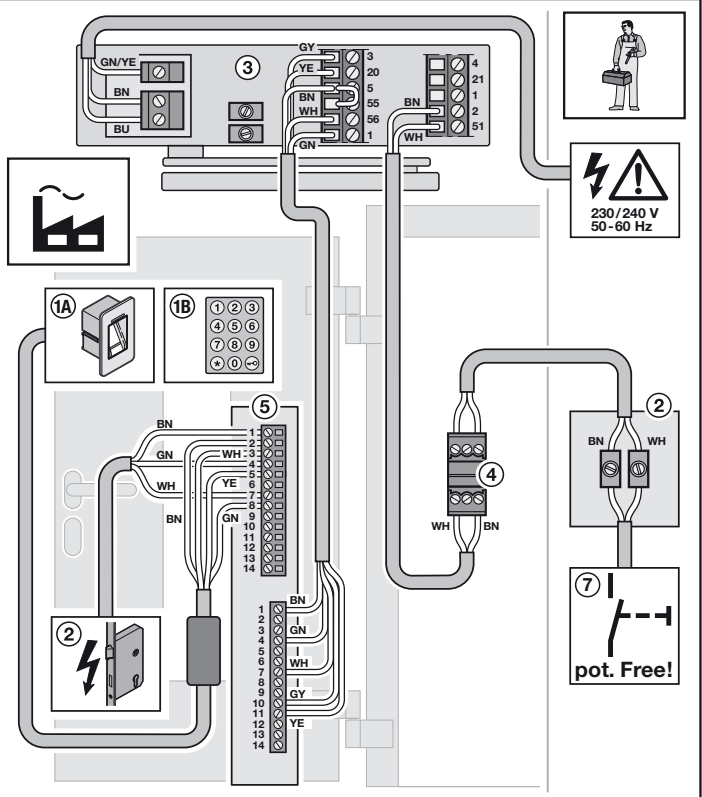

9

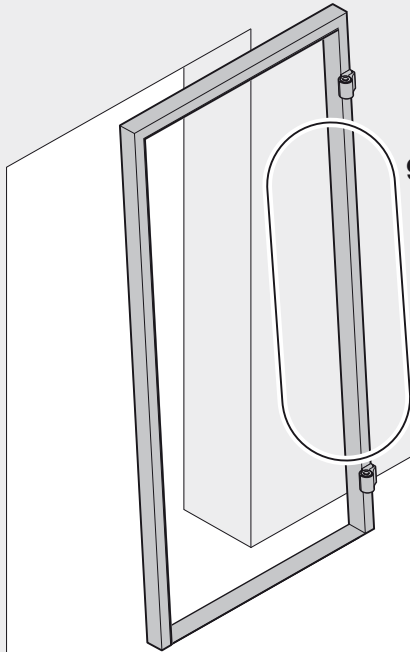

9.1

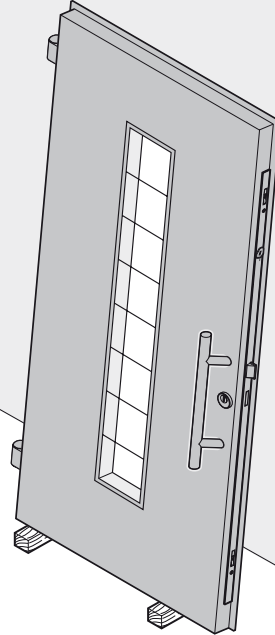

9.1

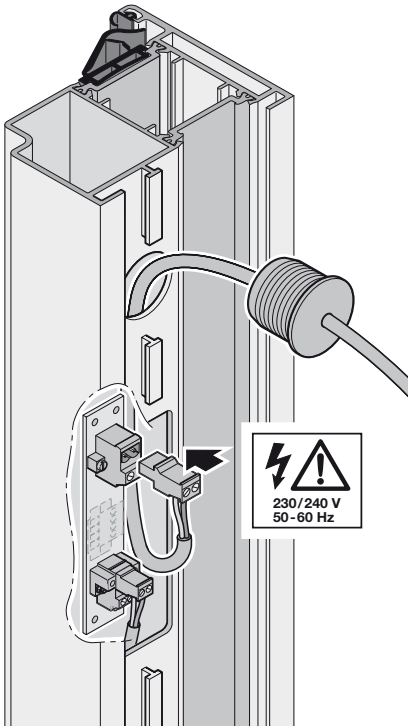

1

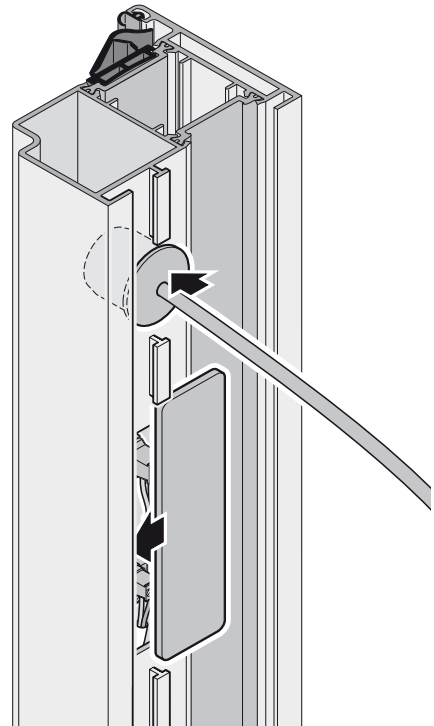

2

10

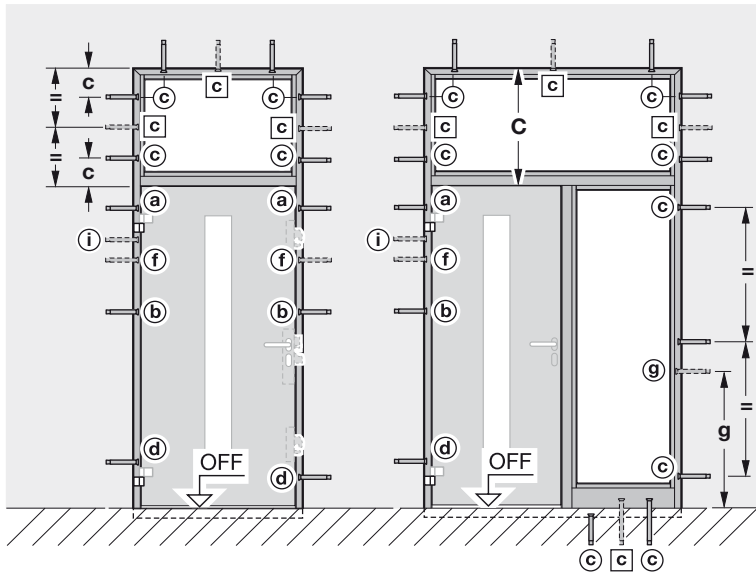
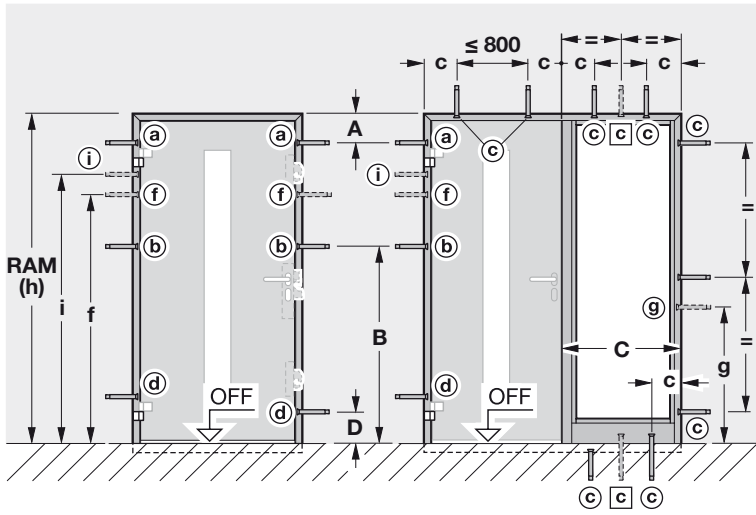

- (a) $A \approx 150 \pm 50$
- (b) $B \approx 1200 \pm 50$
- (c) $C > 500 \rightarrow$
 $c \approx 200 \pm 50$
- (c) $C \leq 500 \rightarrow$
 $c \approx 0.5 \times C$
- (d) $D \approx 115$

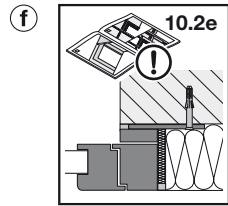
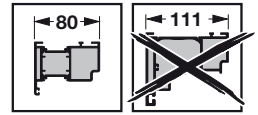

$RAM(h) \geq 2300 \rightarrow$
 $f \approx 1650 \pm 50$

$RAM(h) \geq 2450 \rightarrow$
 $f \approx 1920 \pm 50$

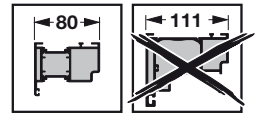

$g \approx 970 \pm 50$

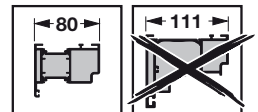

- (i) $RAM(h) \geq 2300 \rightarrow$
 $i = 1650$
- $RAM(h) \geq 2450 \rightarrow$
 $i = 1920$

10.1

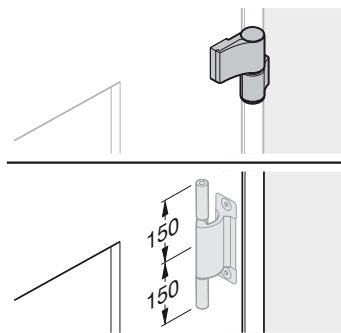
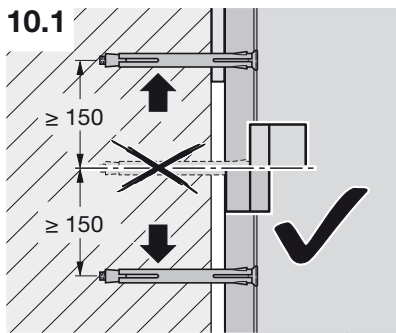

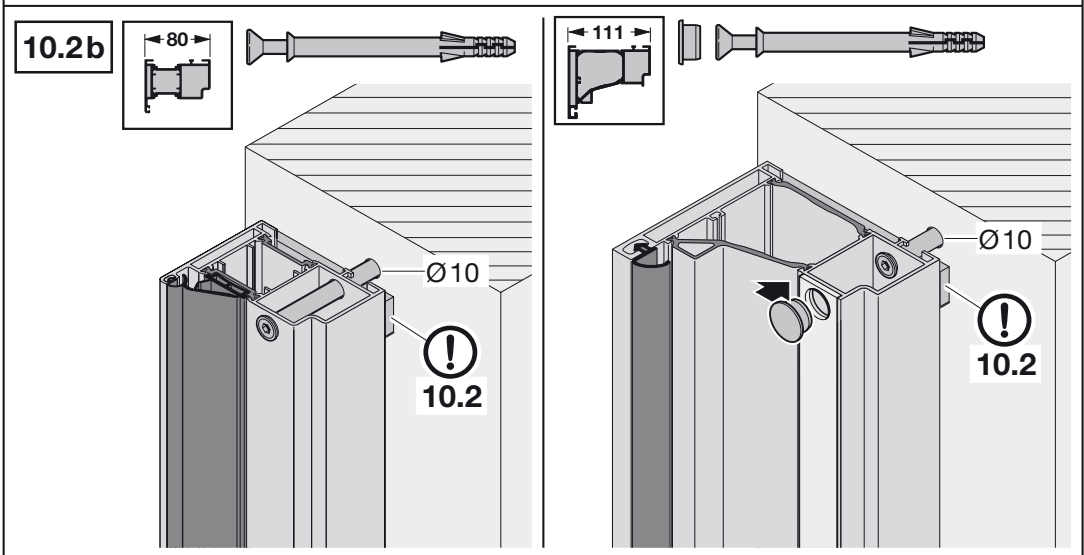
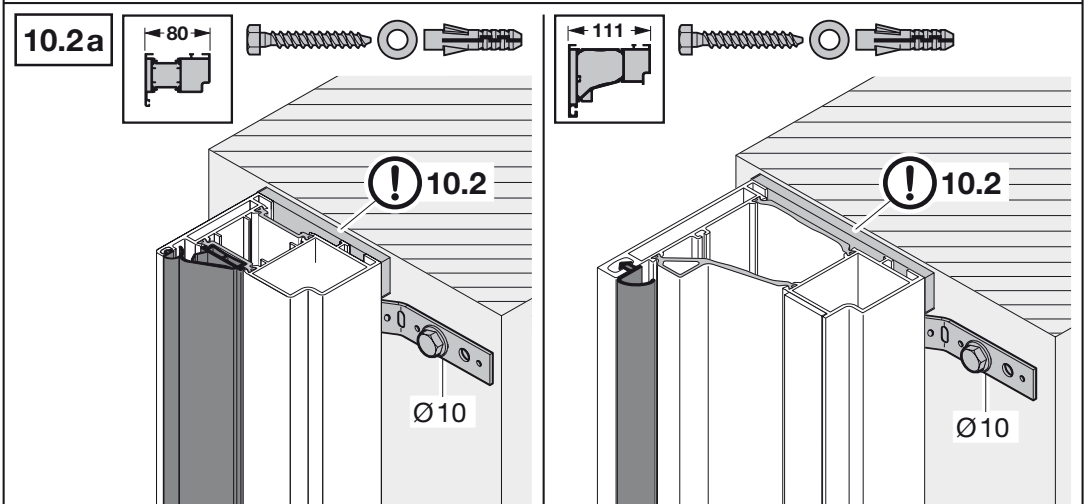
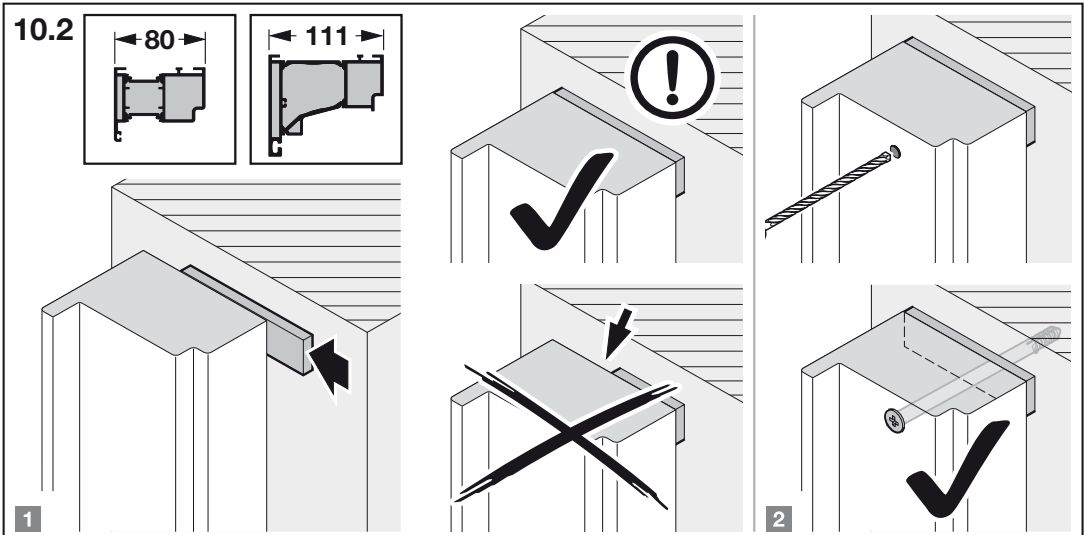

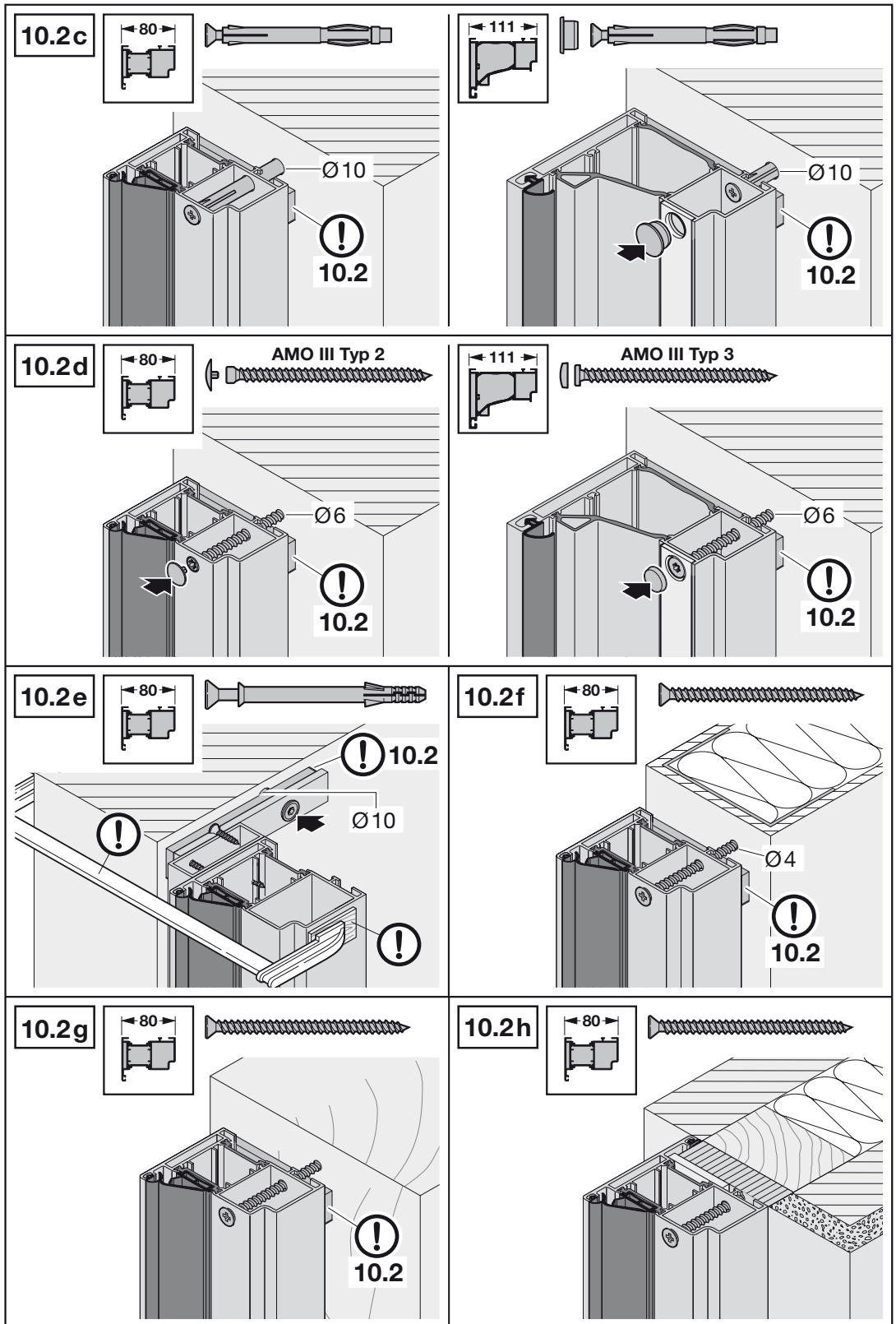

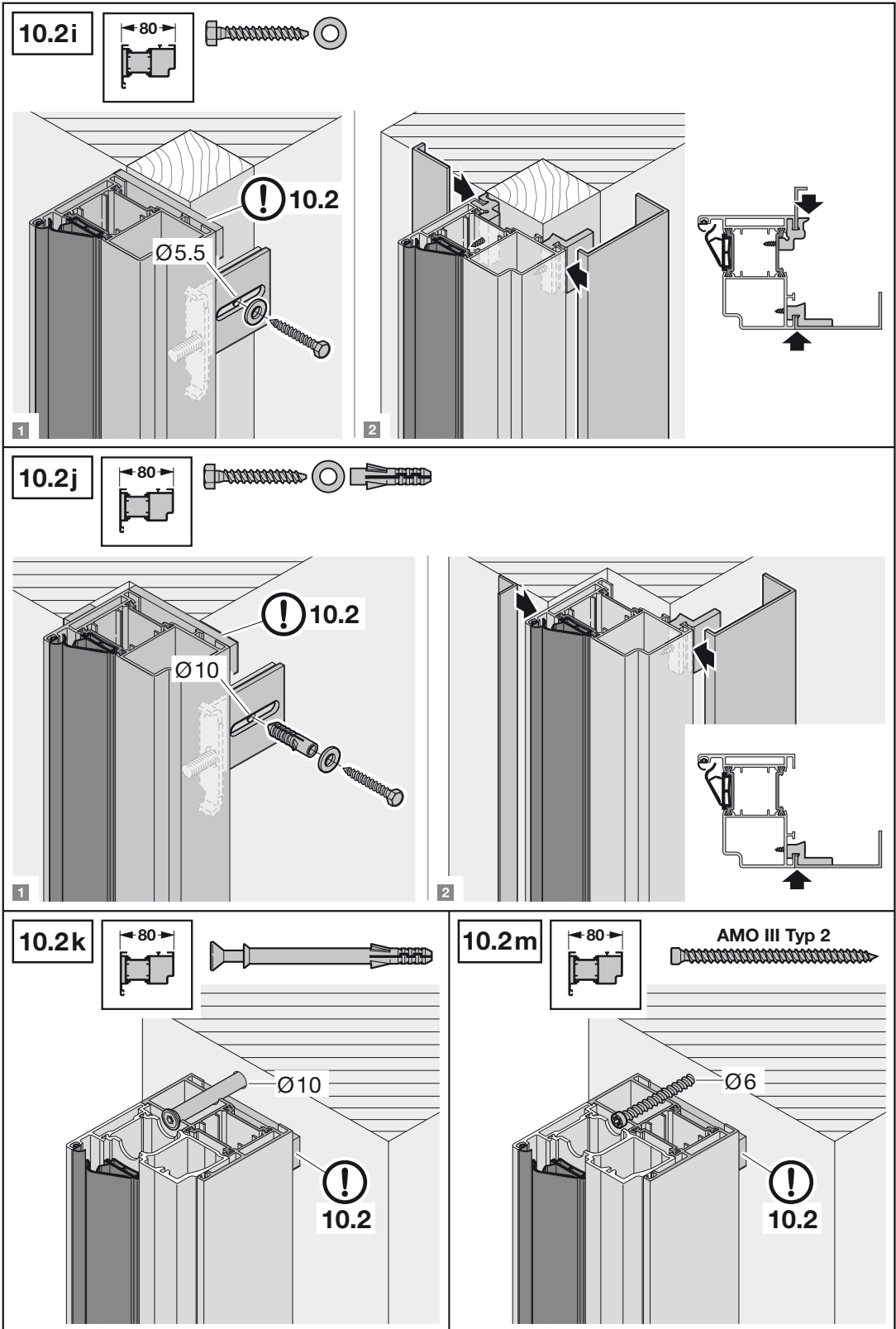

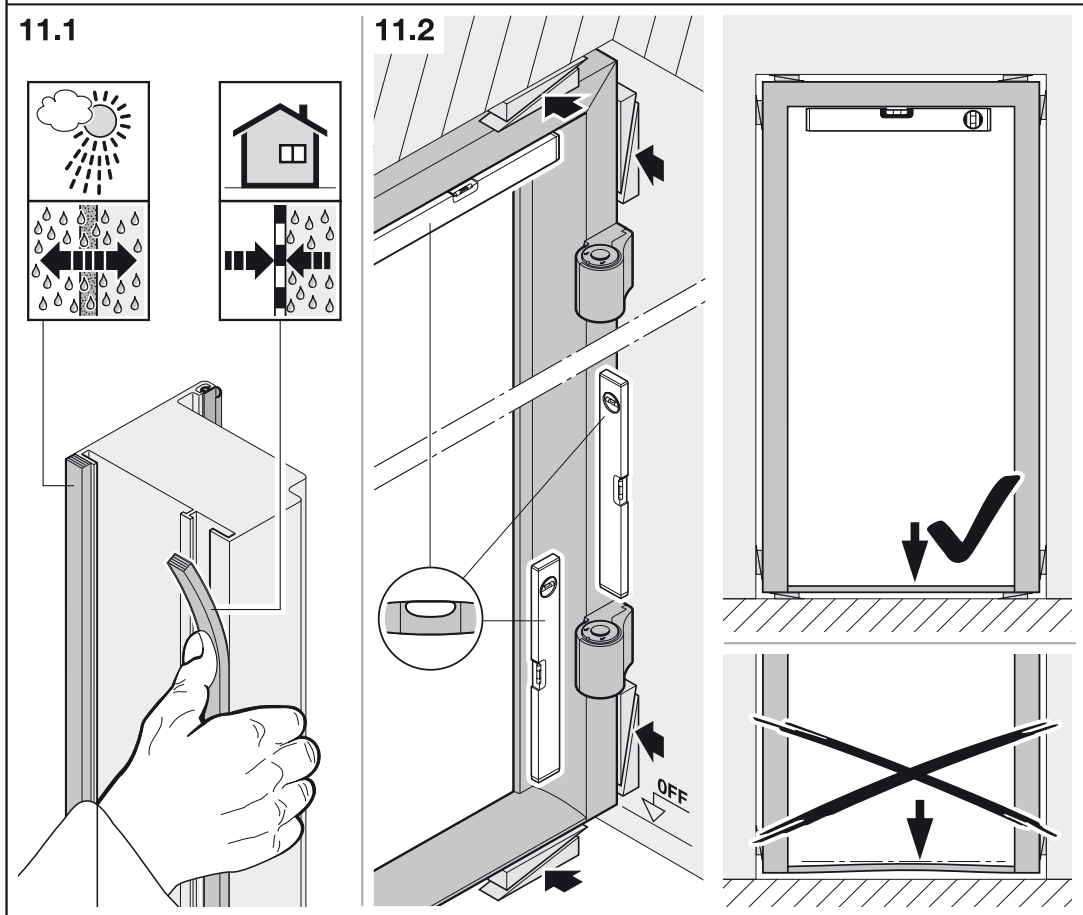
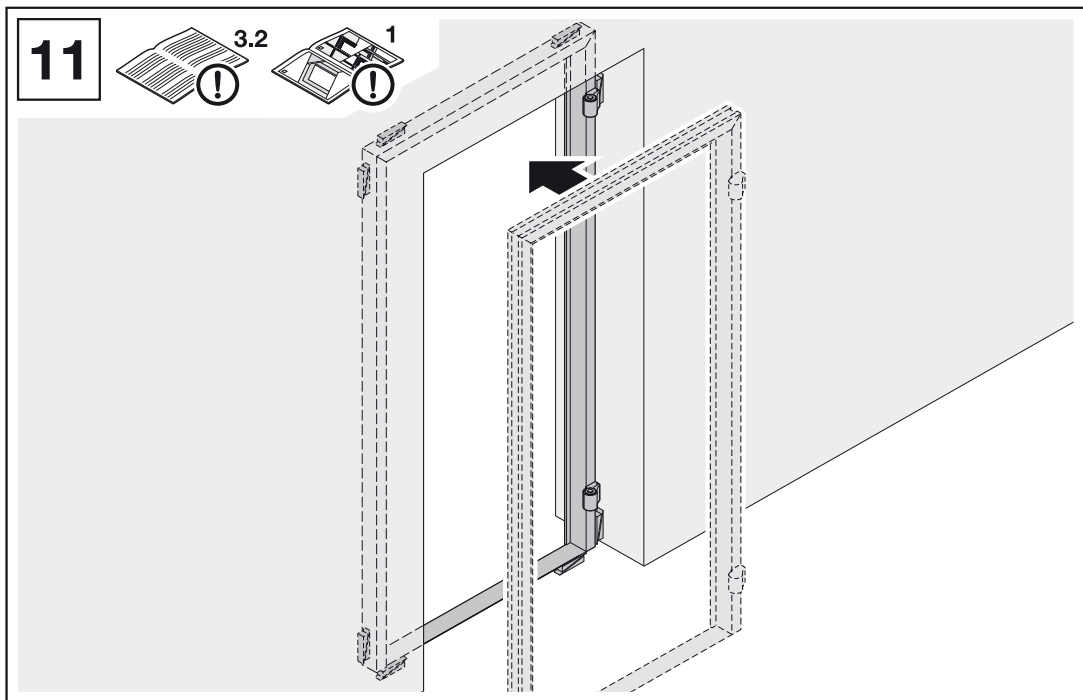

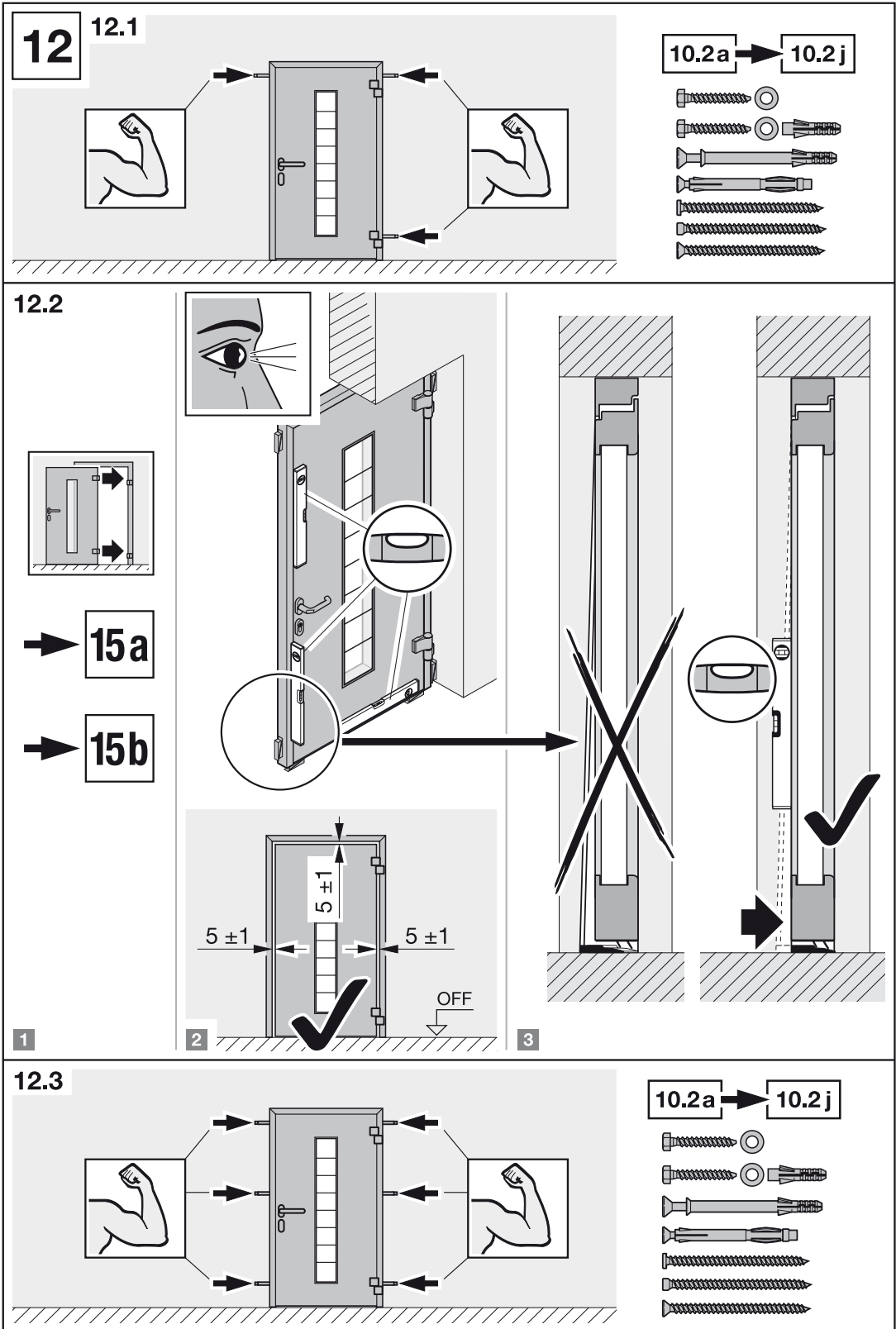

13

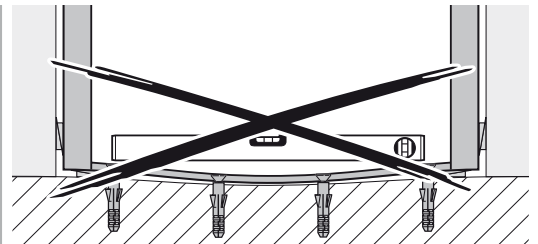
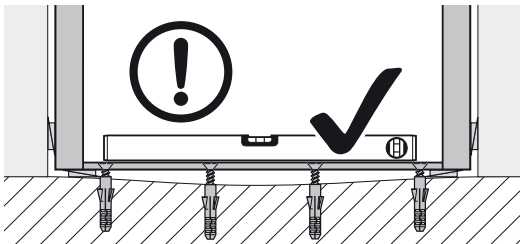
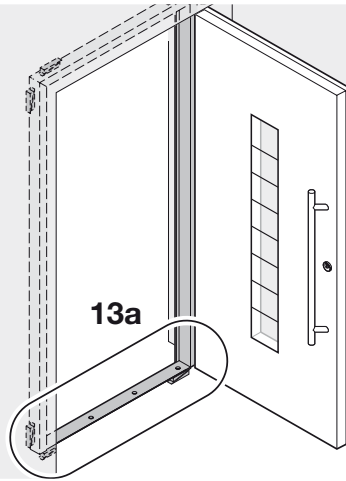

13a

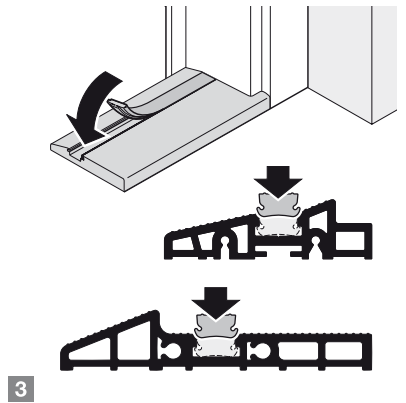
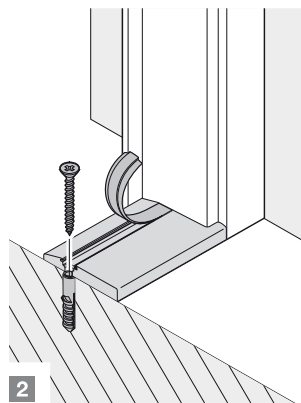
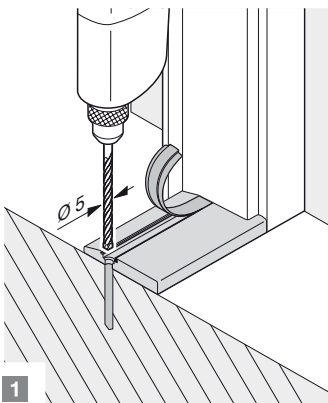
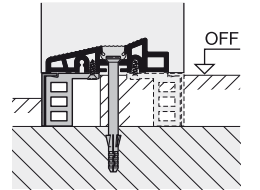
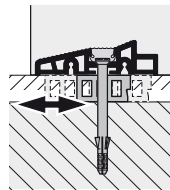
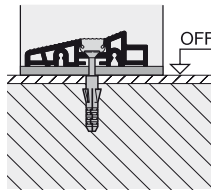
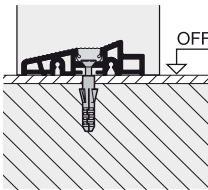
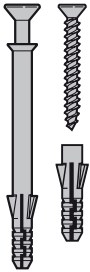
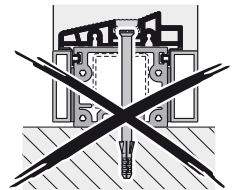
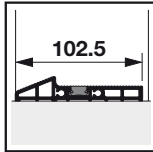
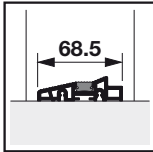

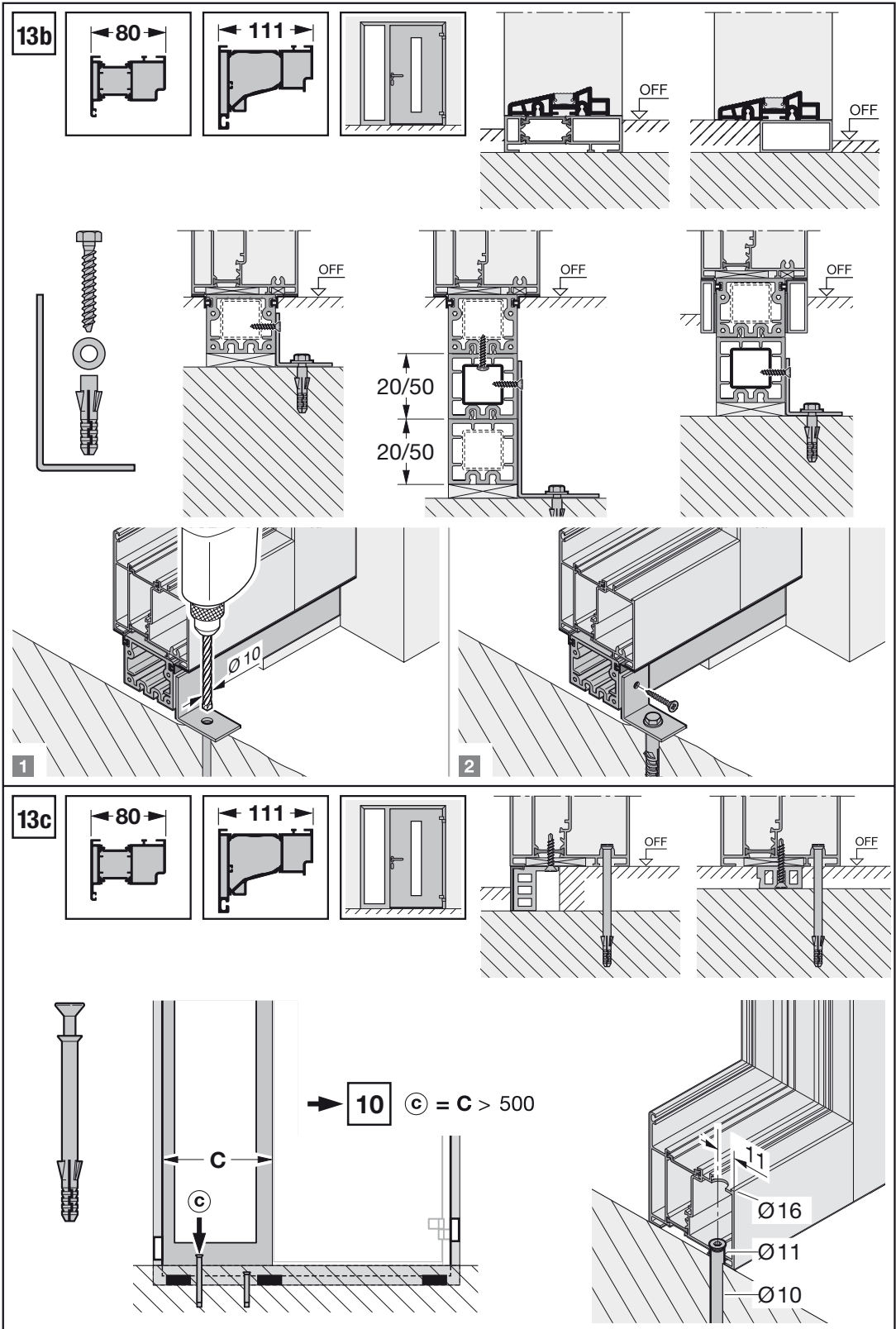

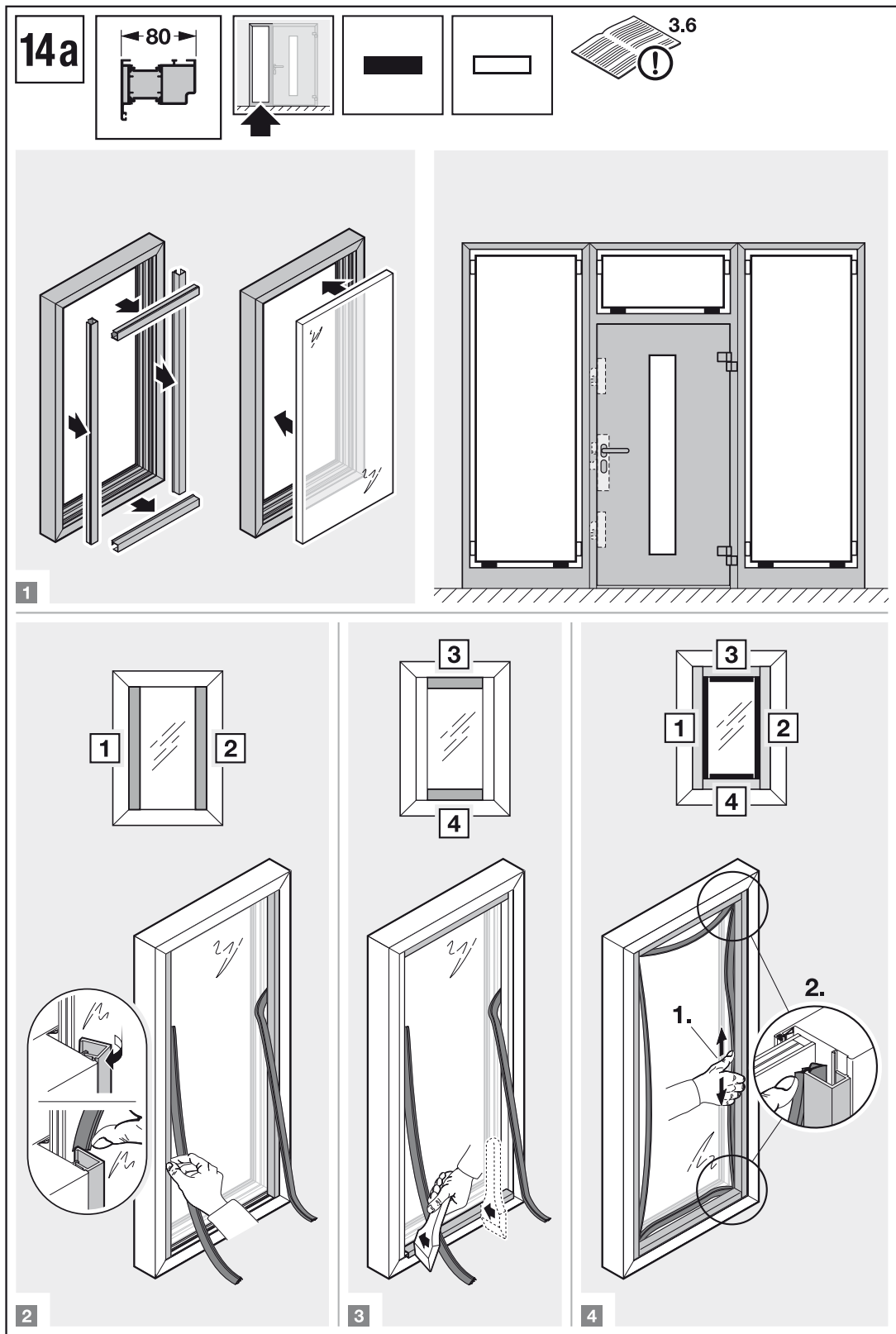

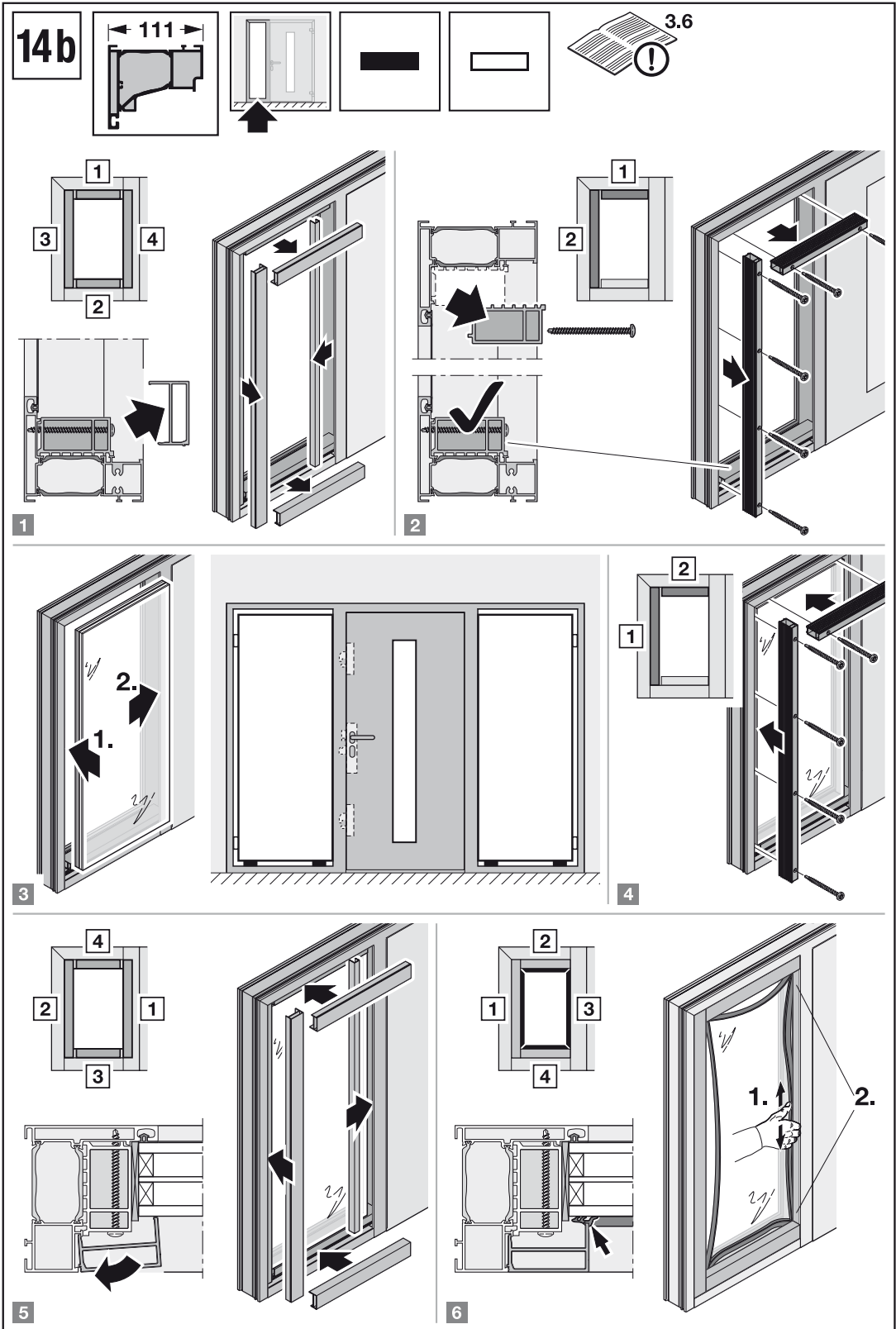

15

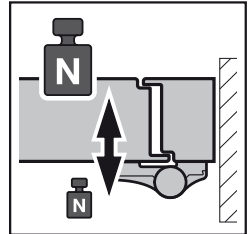
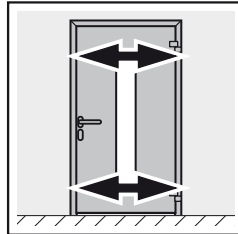
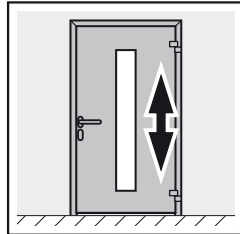
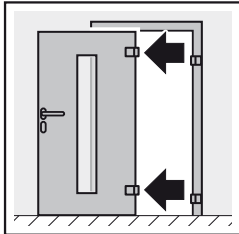
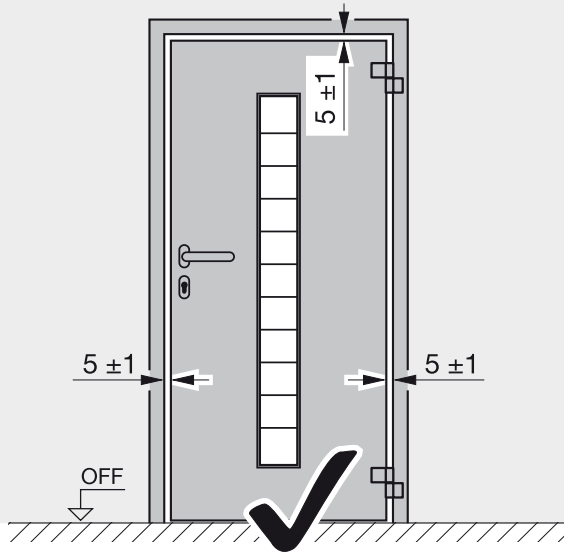
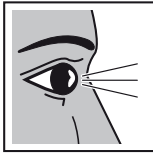

15a

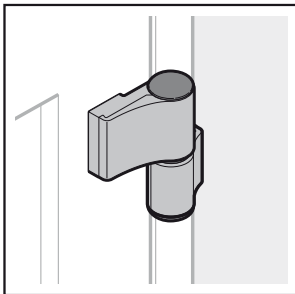

15b

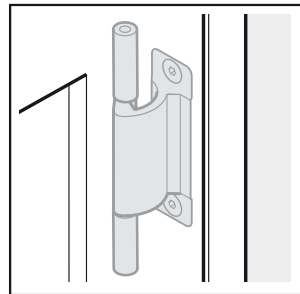

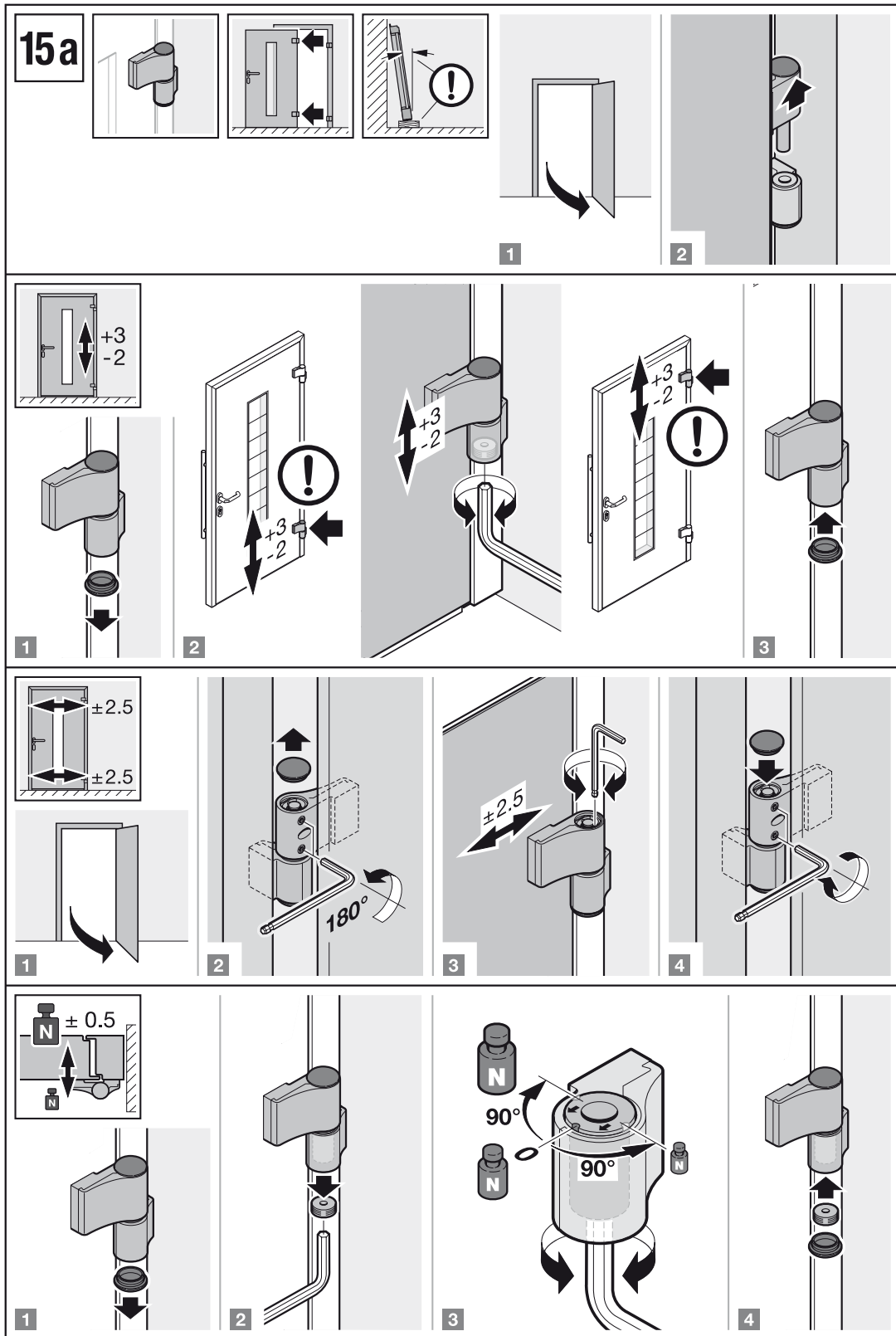

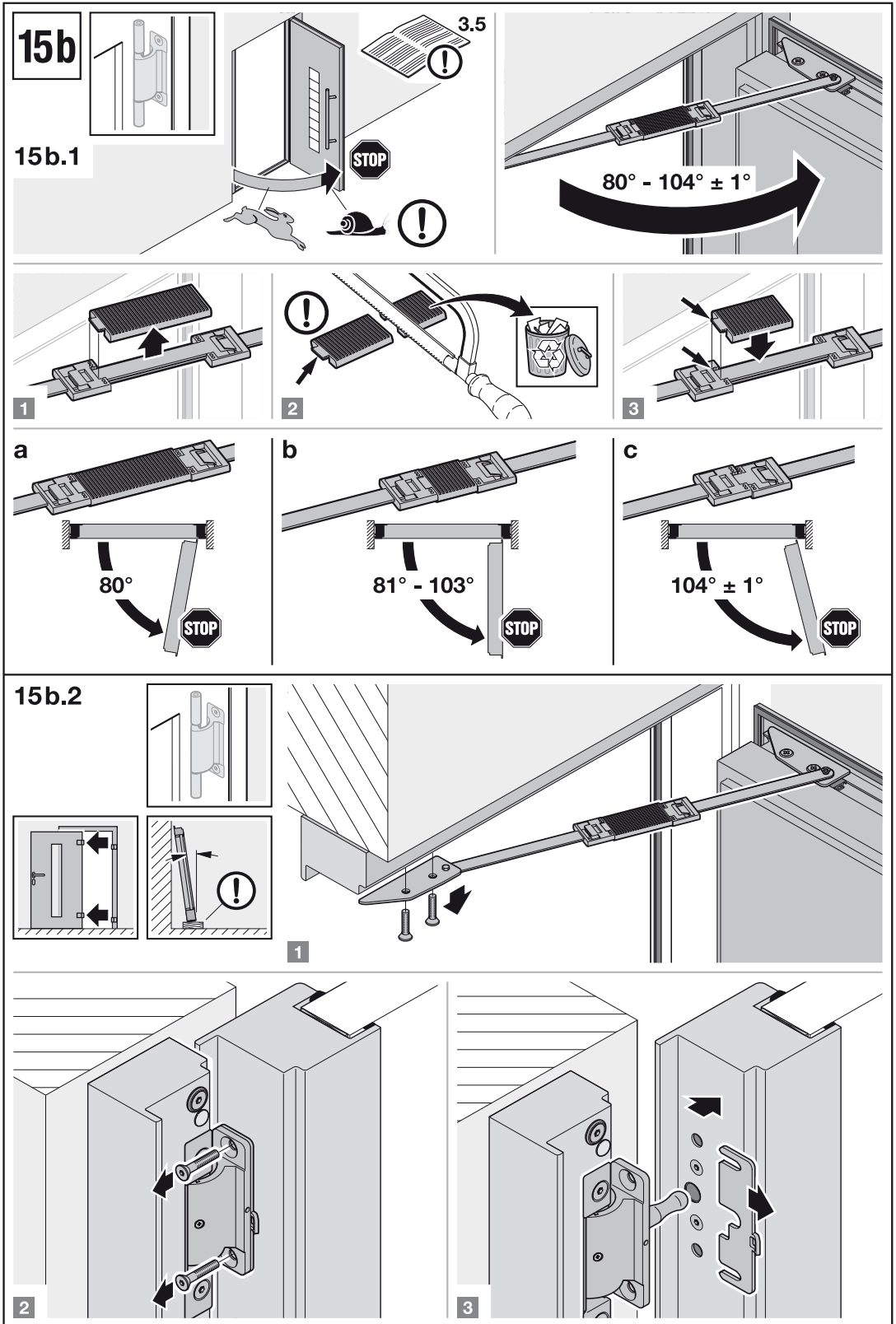

15b.2

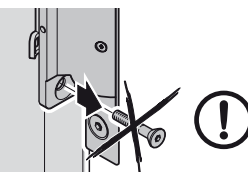
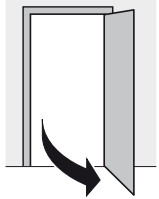
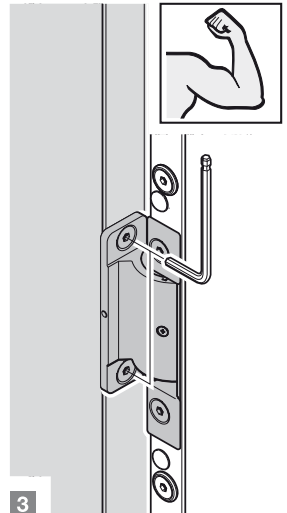
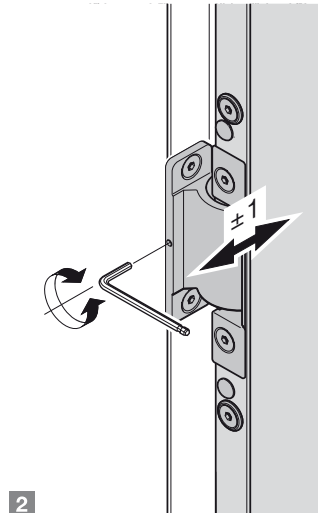
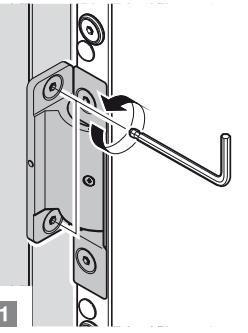
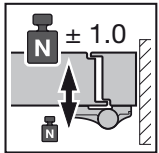
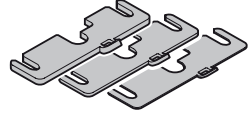
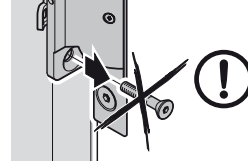
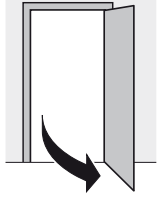
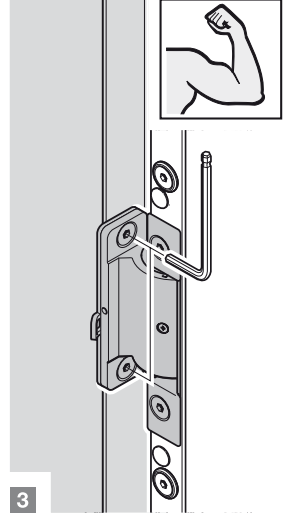
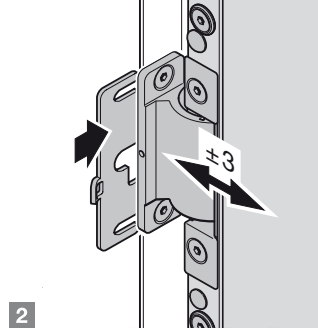
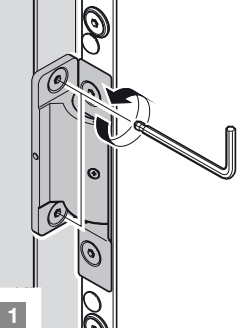
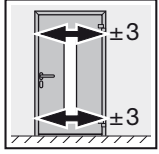
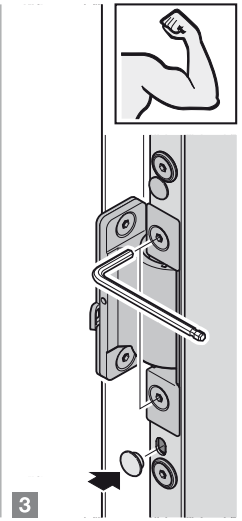
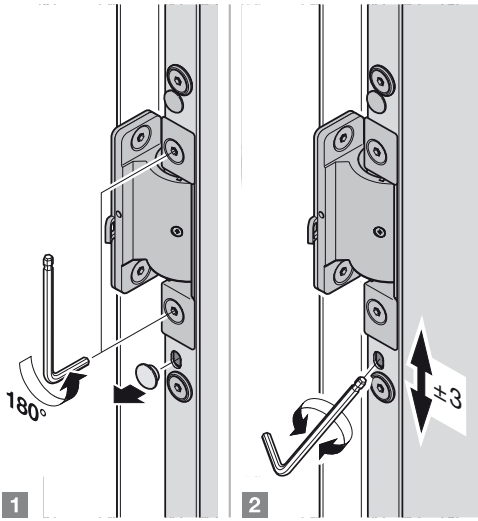
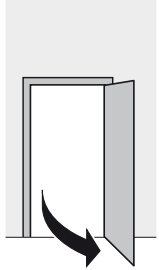
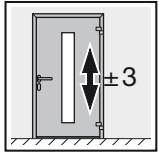

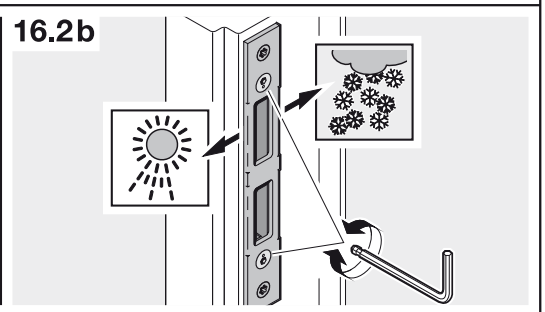
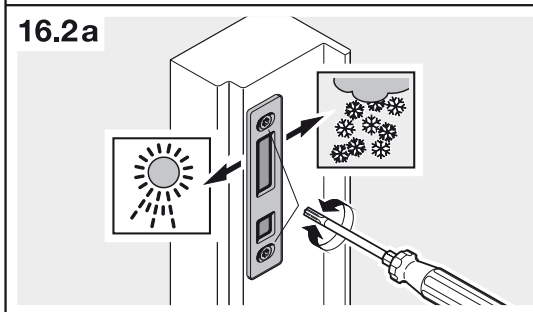
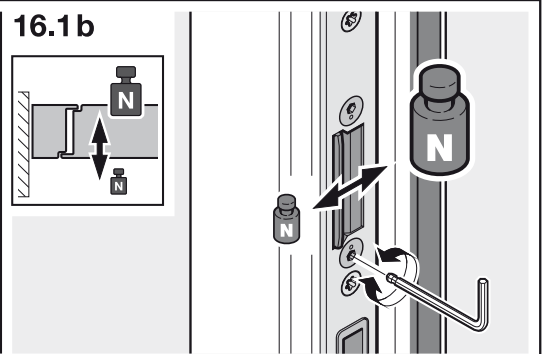
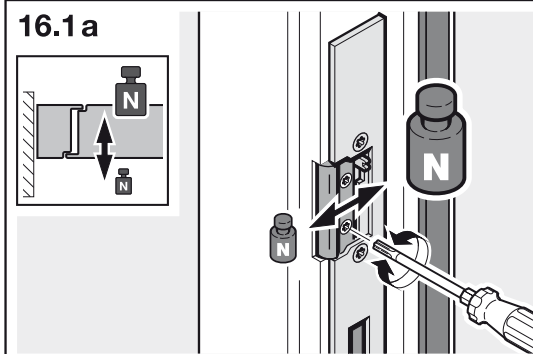
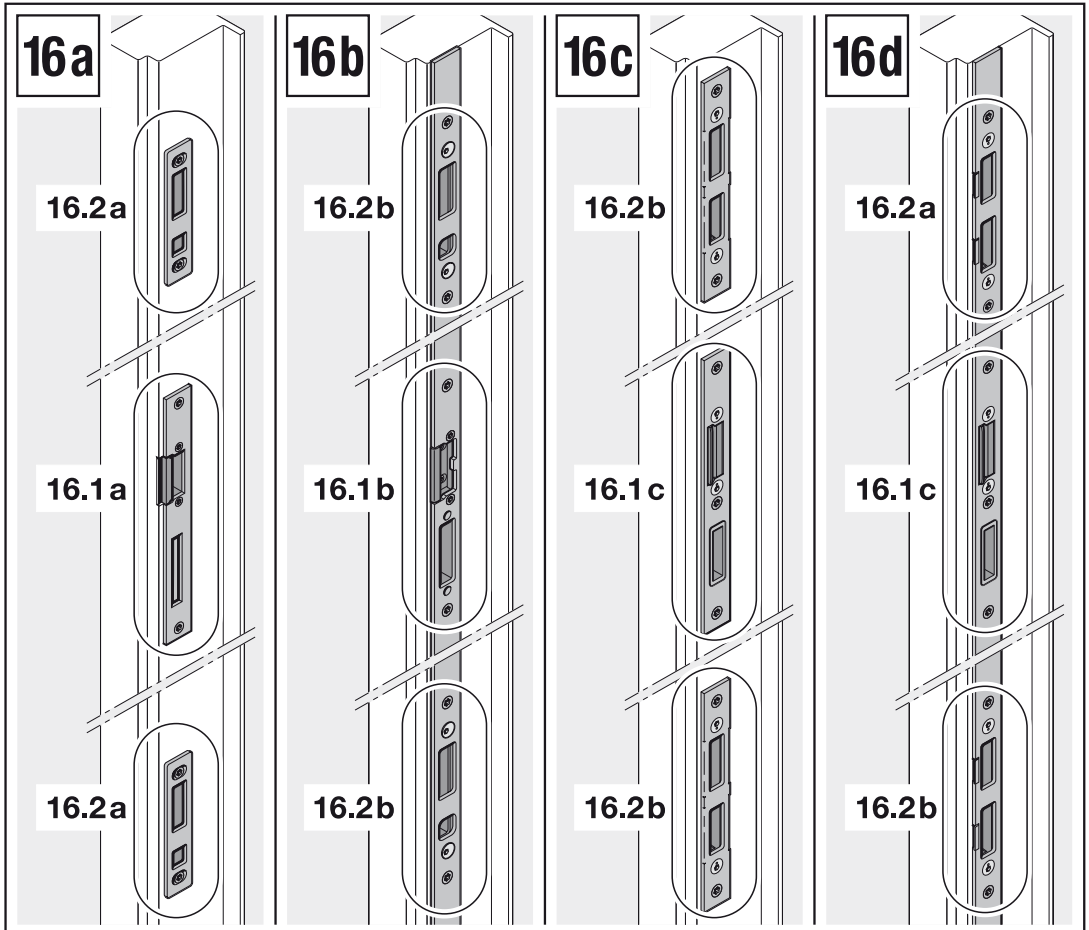

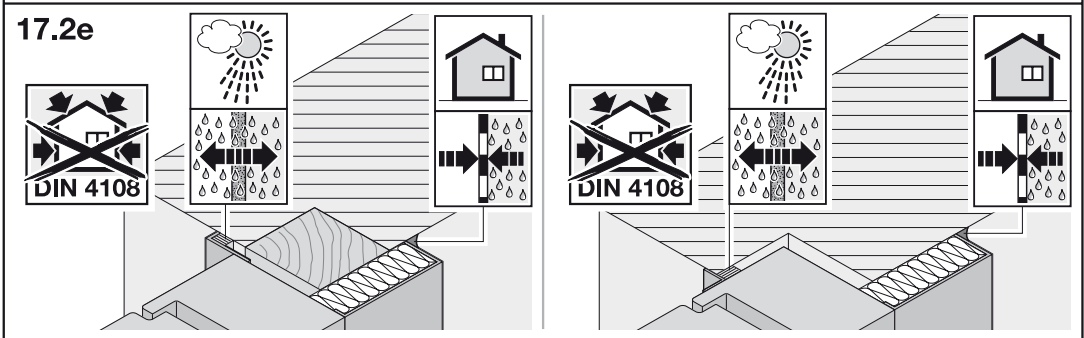
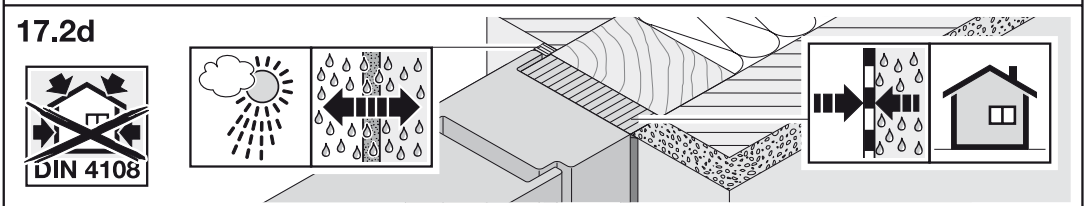
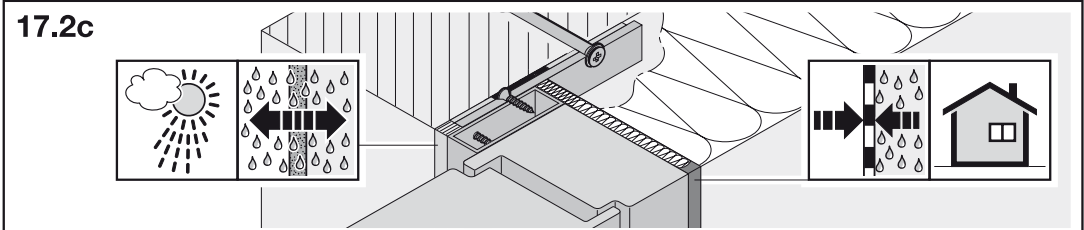
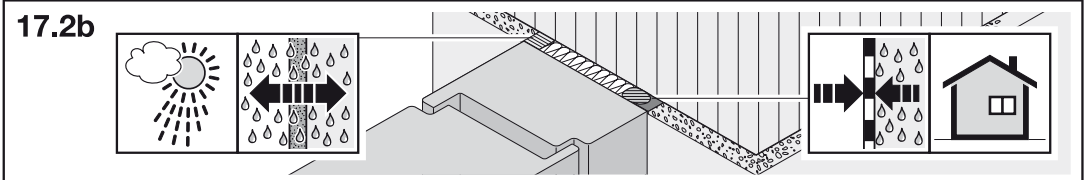
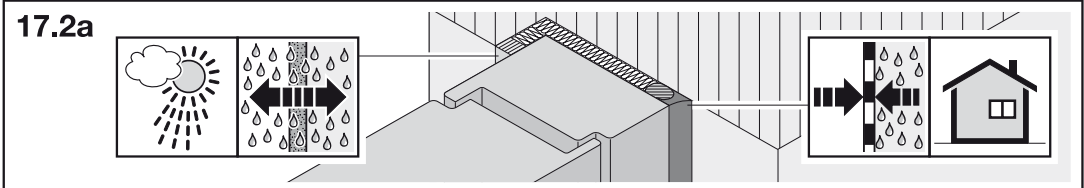
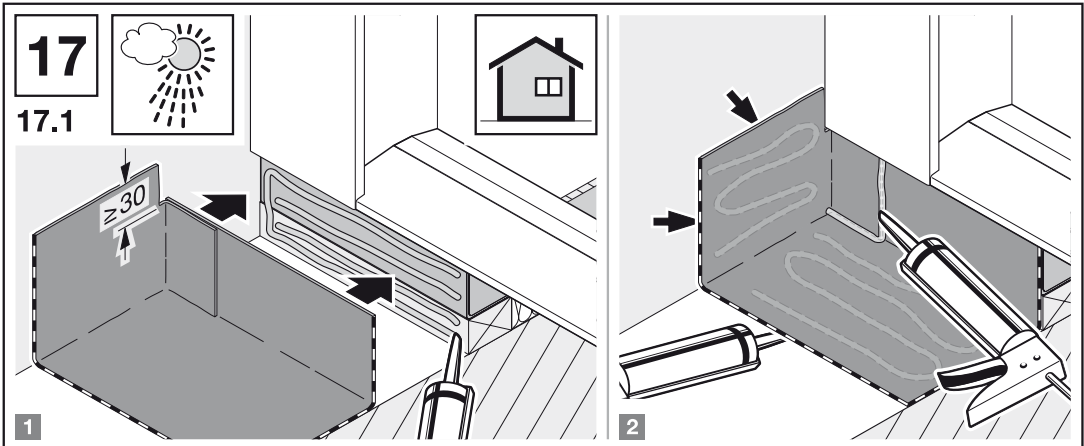

18

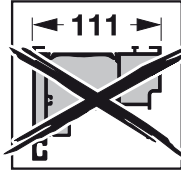
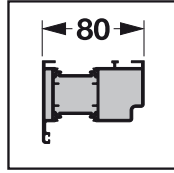

3.3/3.8

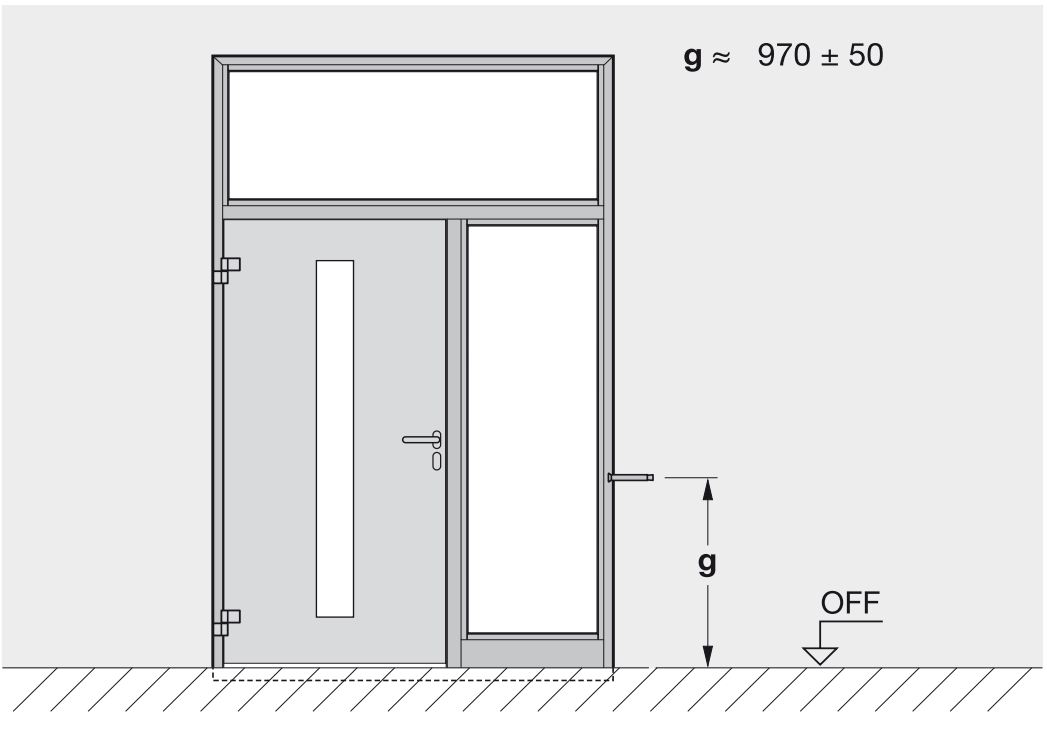
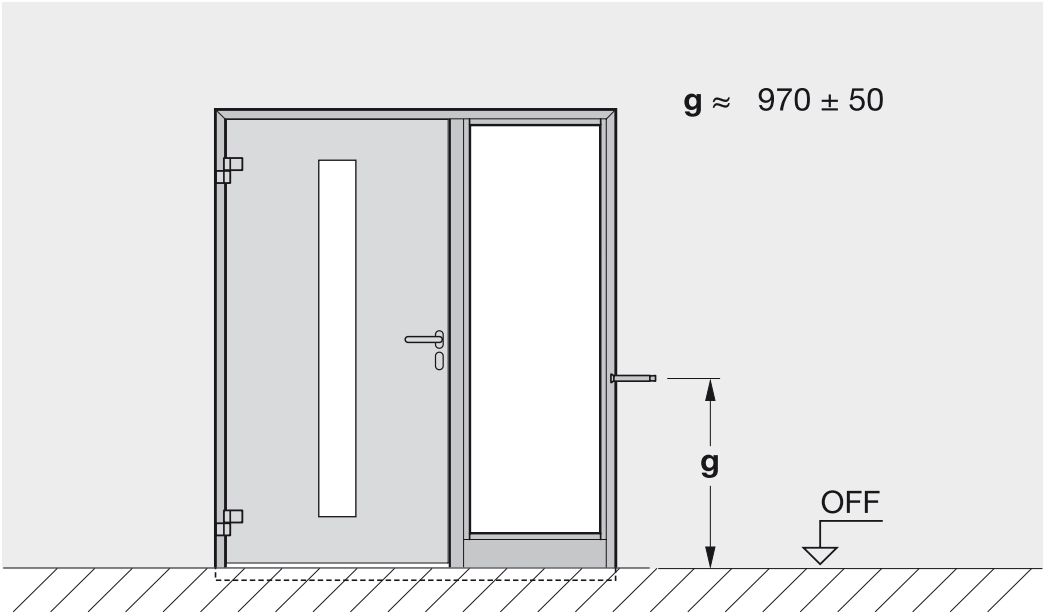

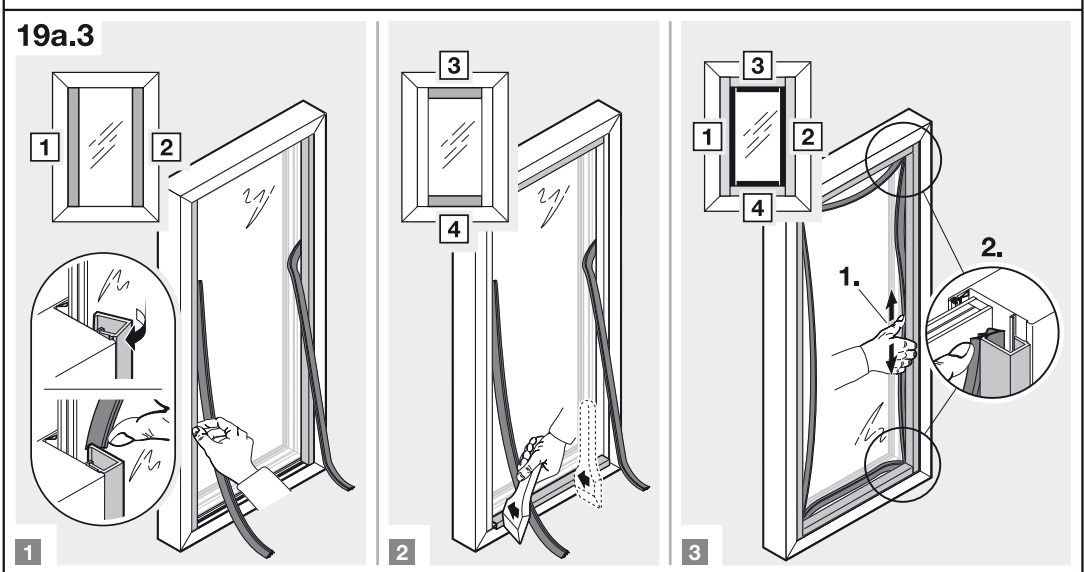
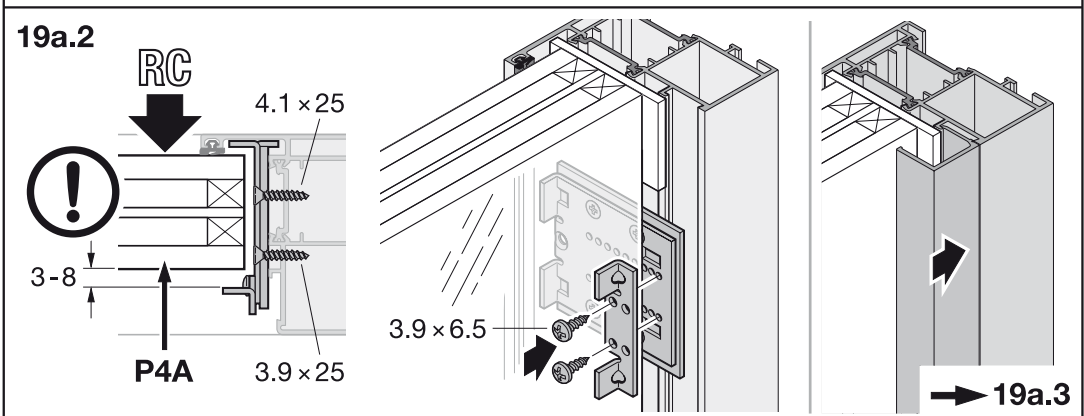
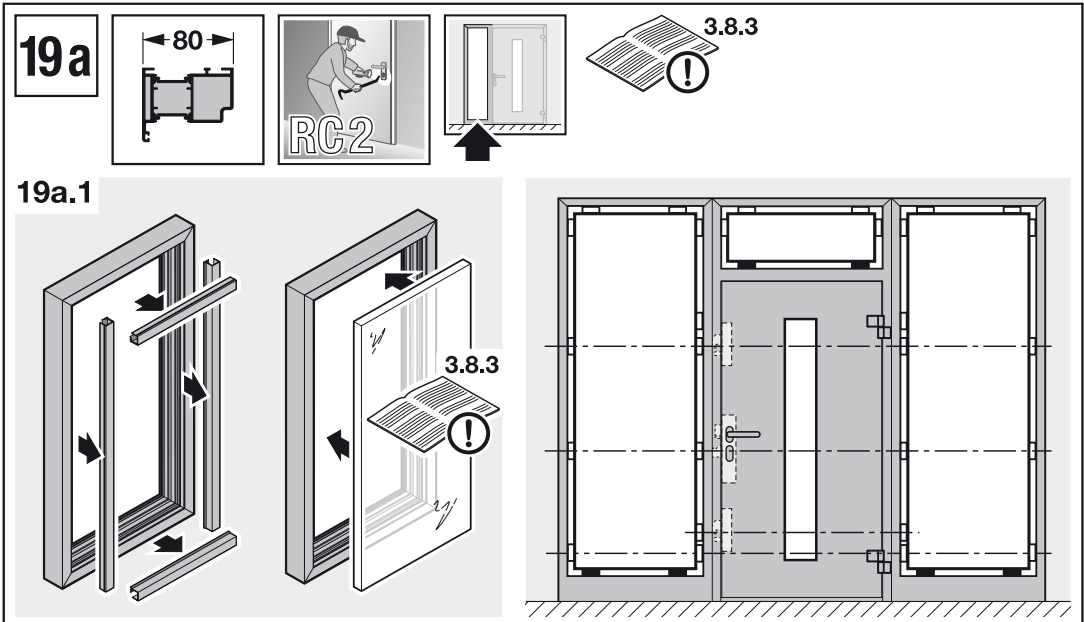

19b.4

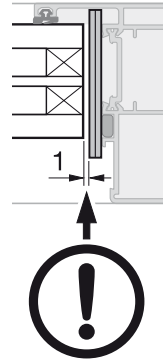
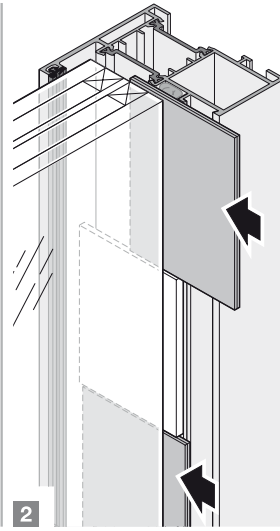
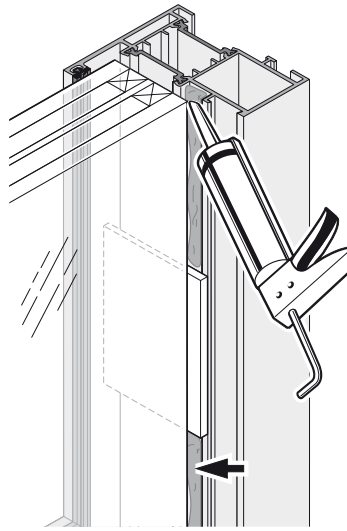
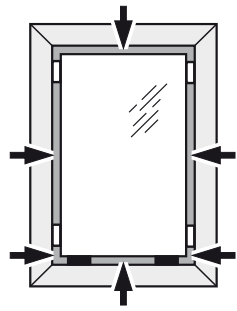

1

2

19b.5

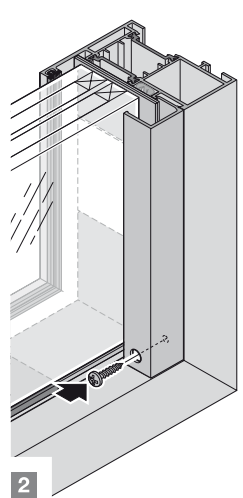
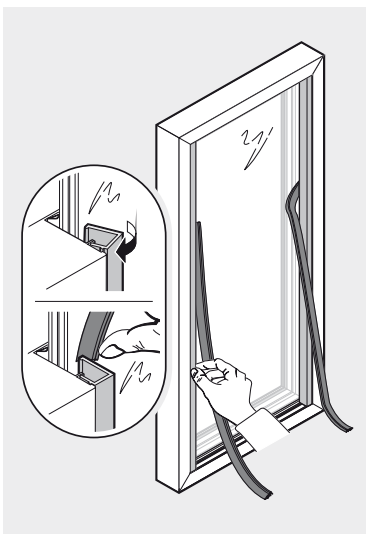
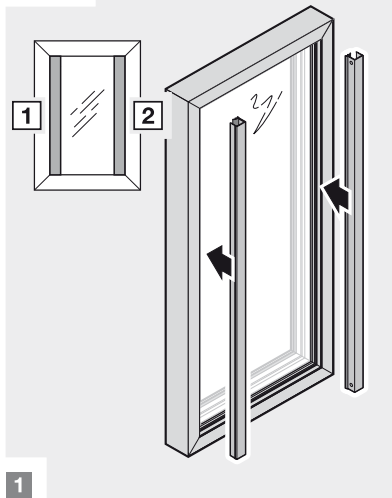

1

2

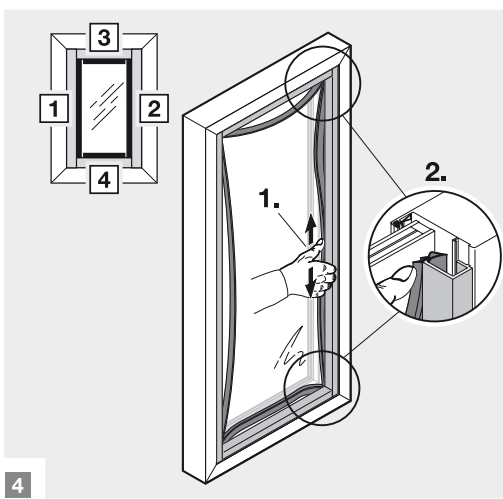
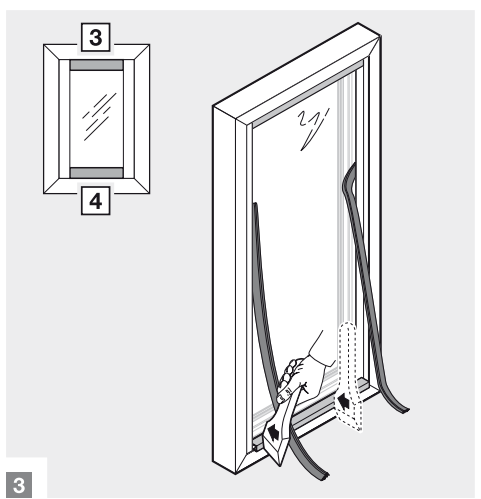

3

4

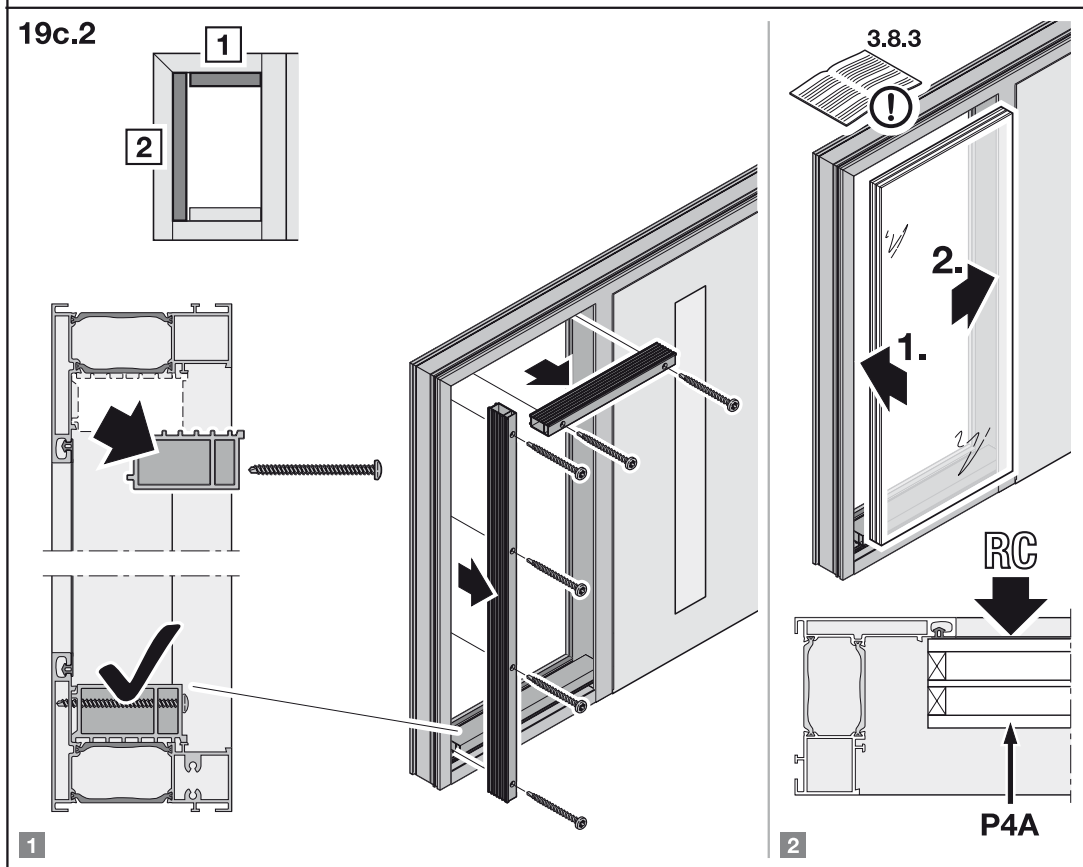
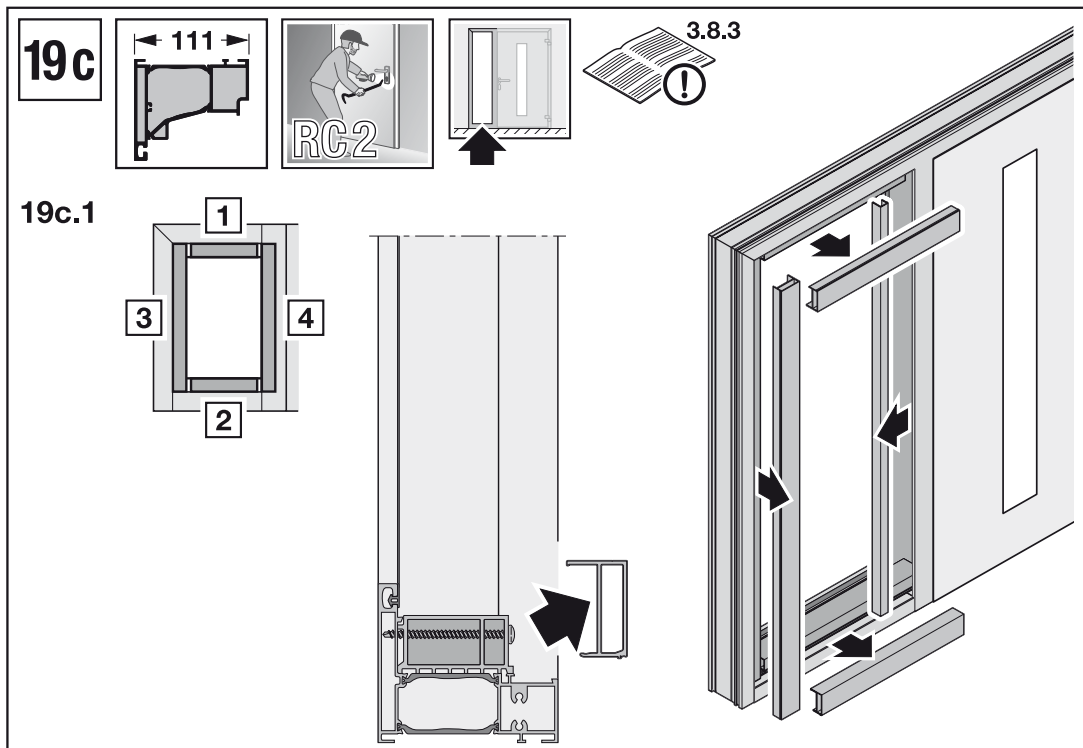

19c.3

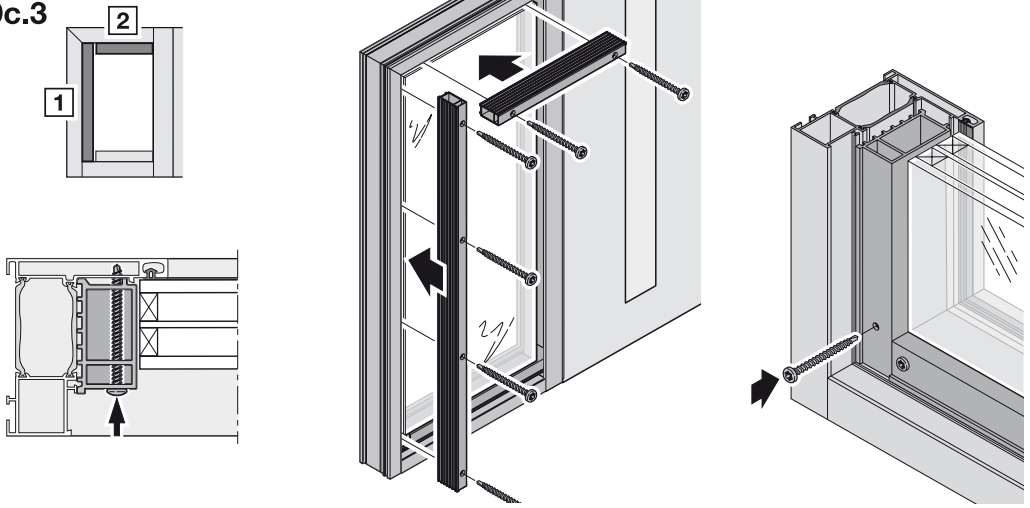

19c.4

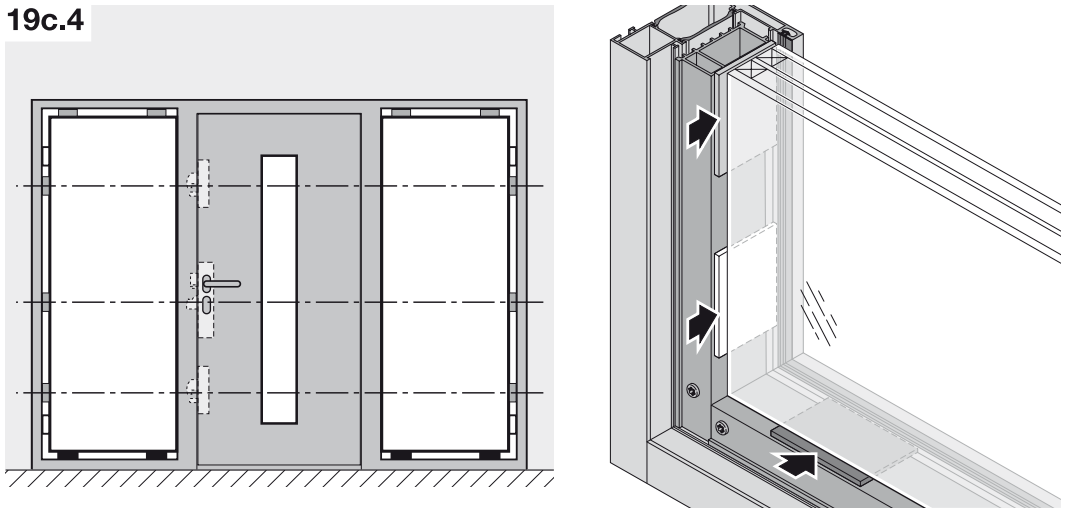

19c.5

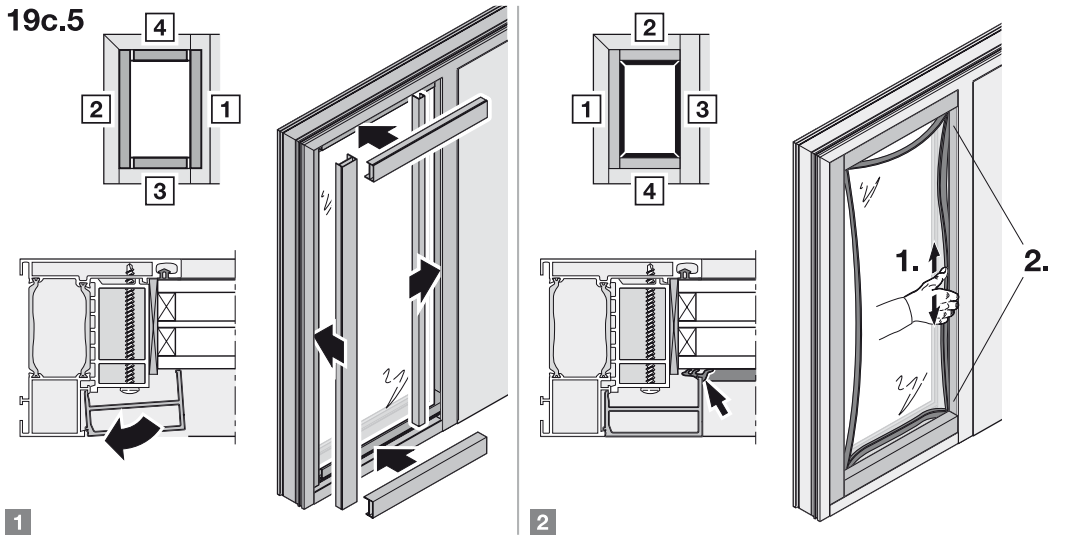

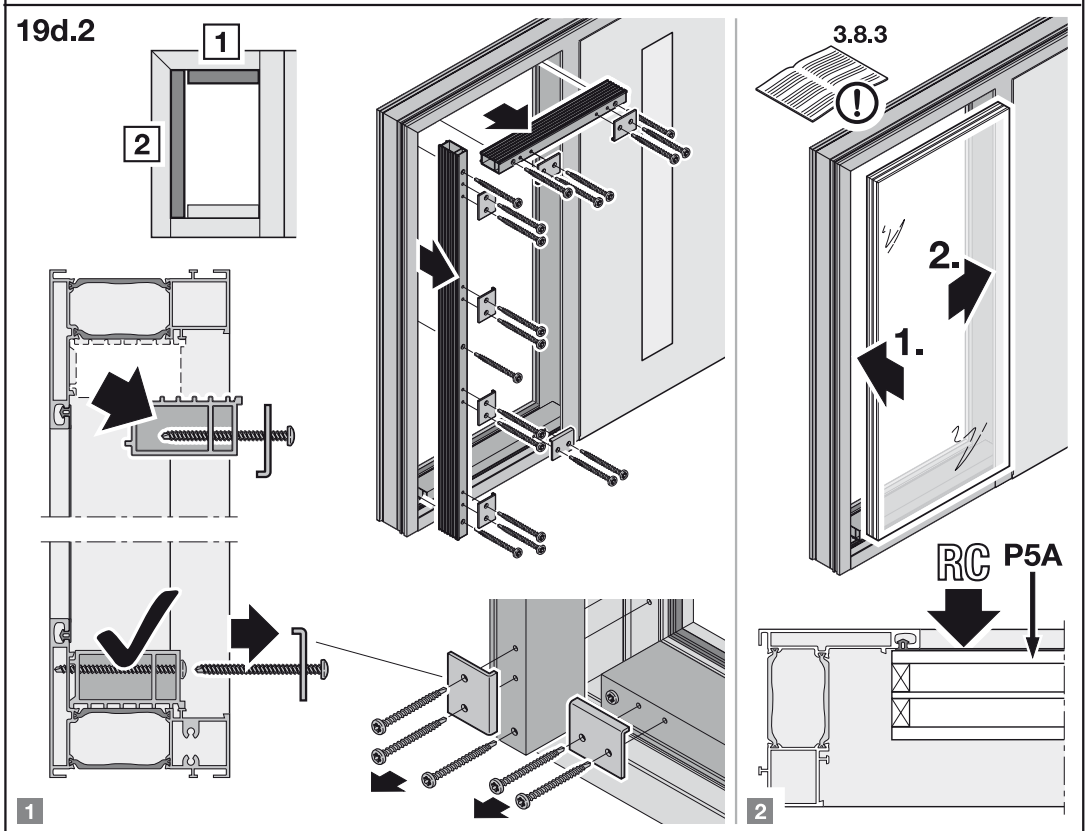

19d.3

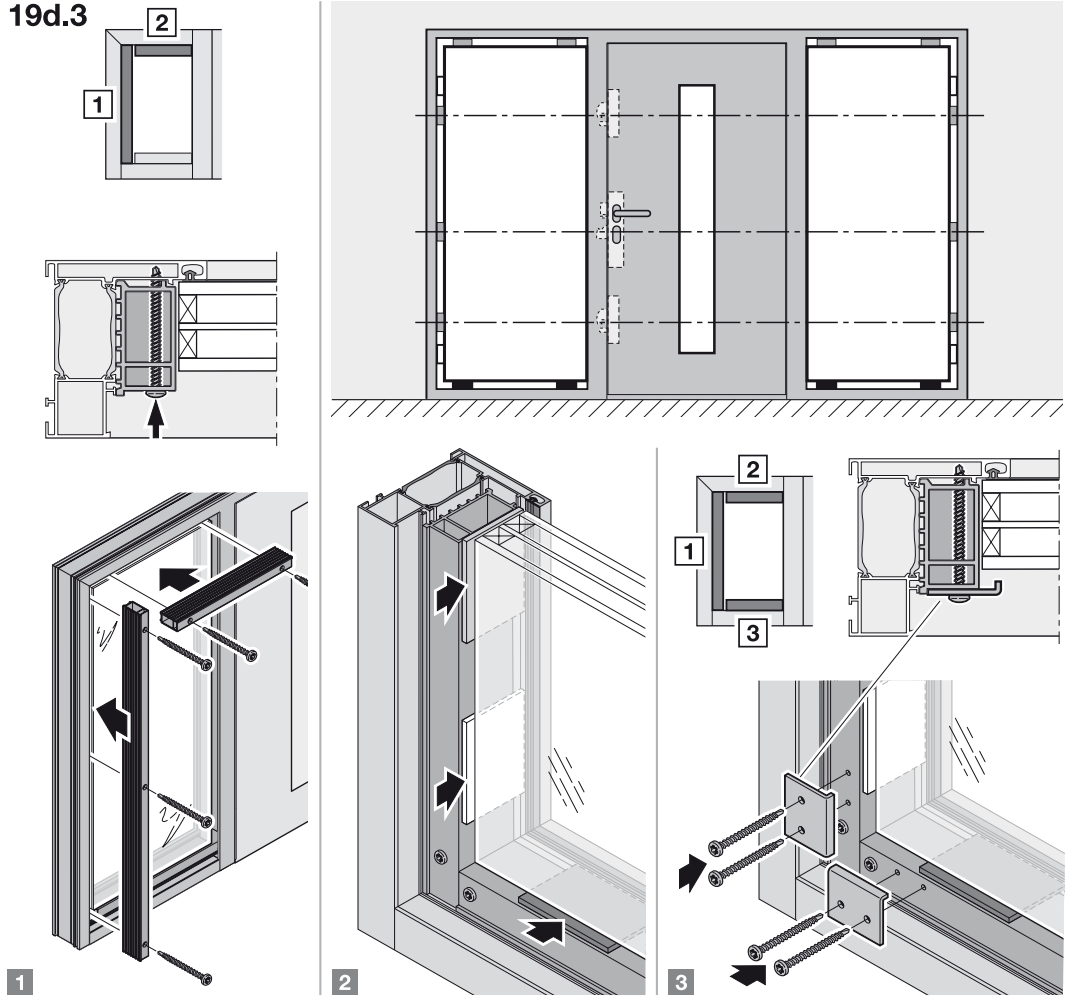

19d.4

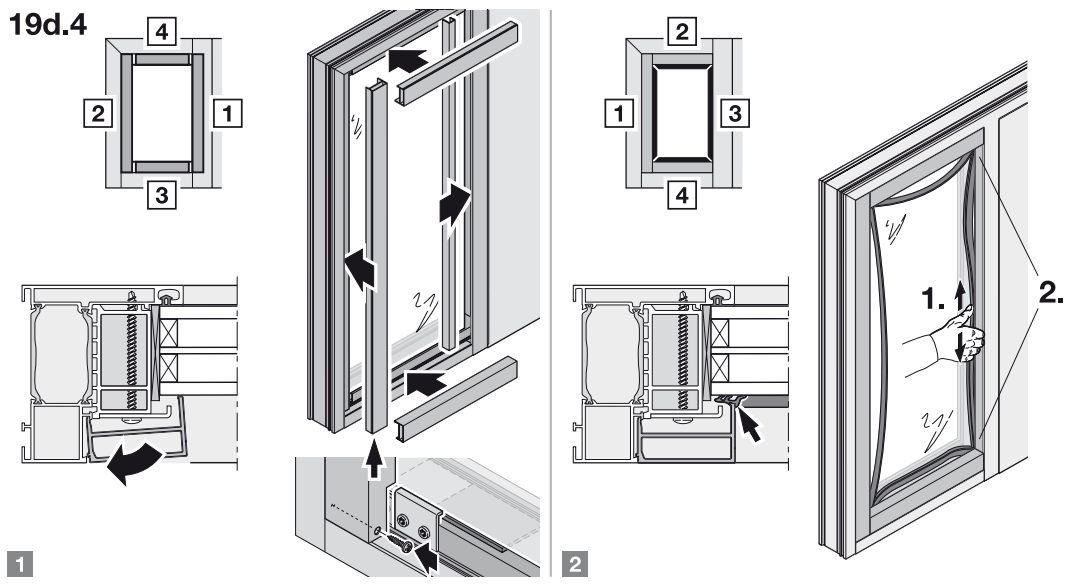

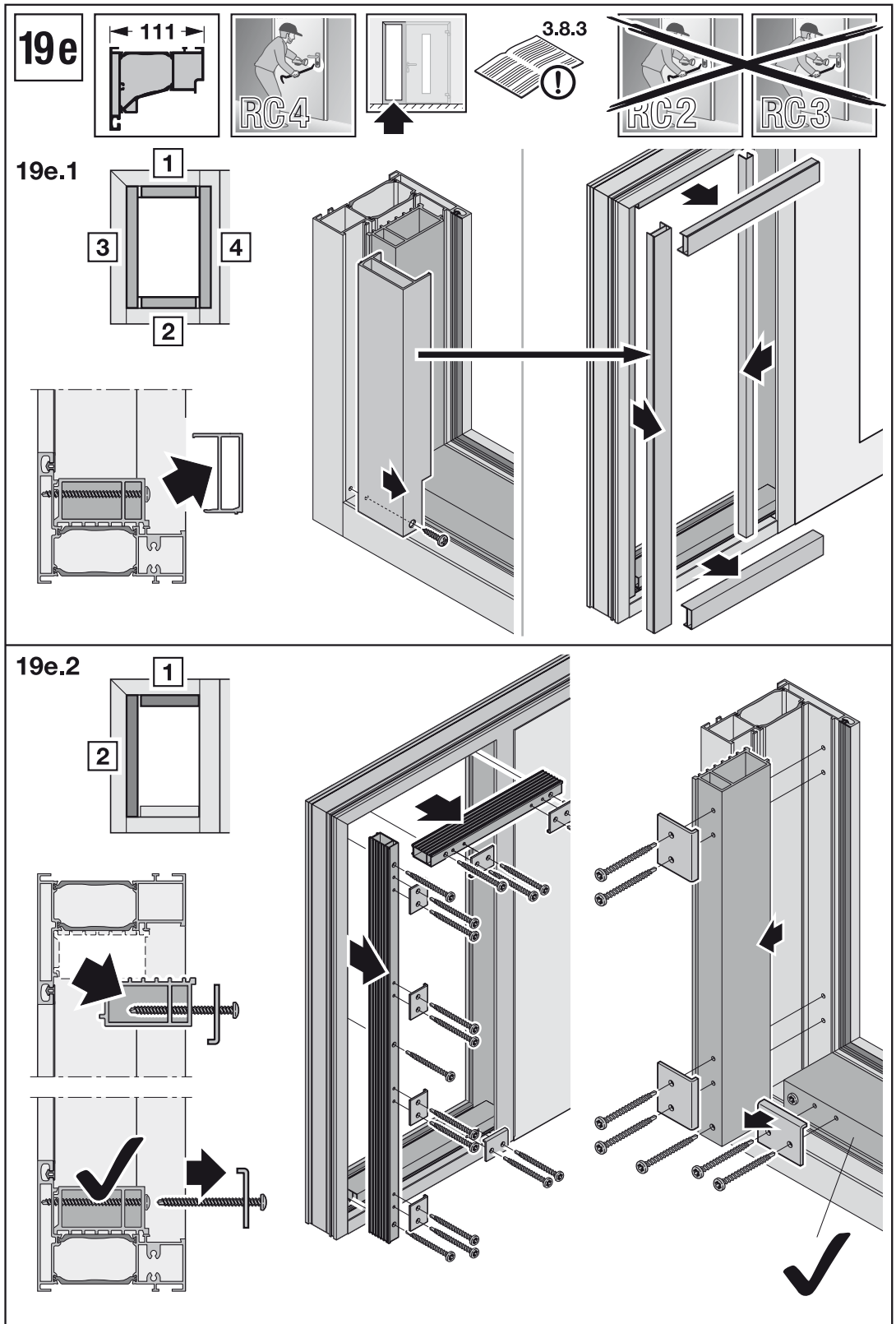

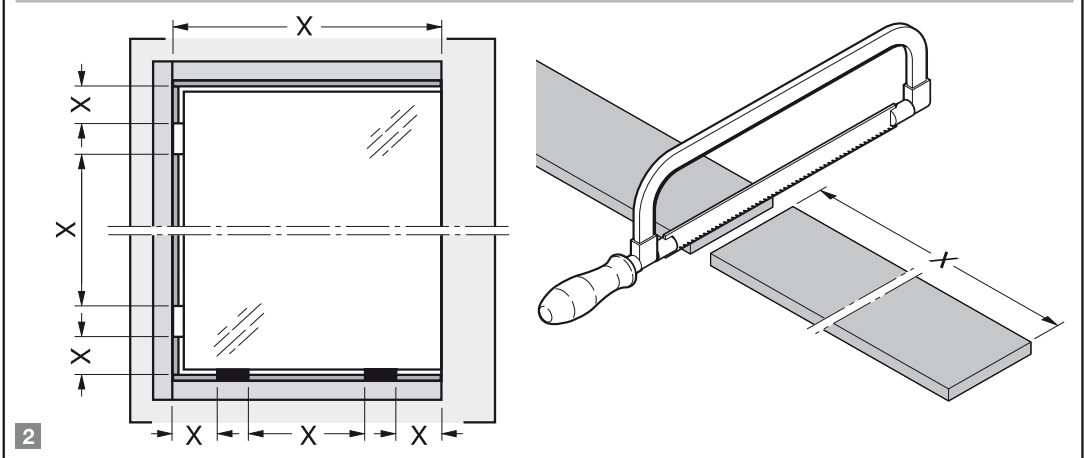
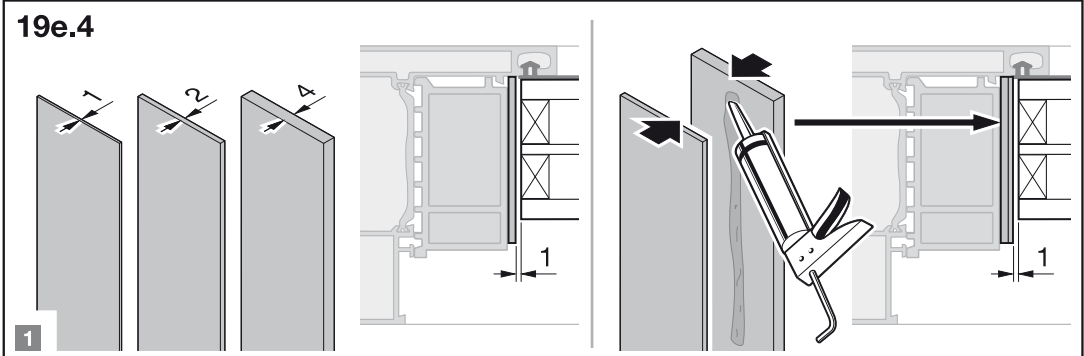
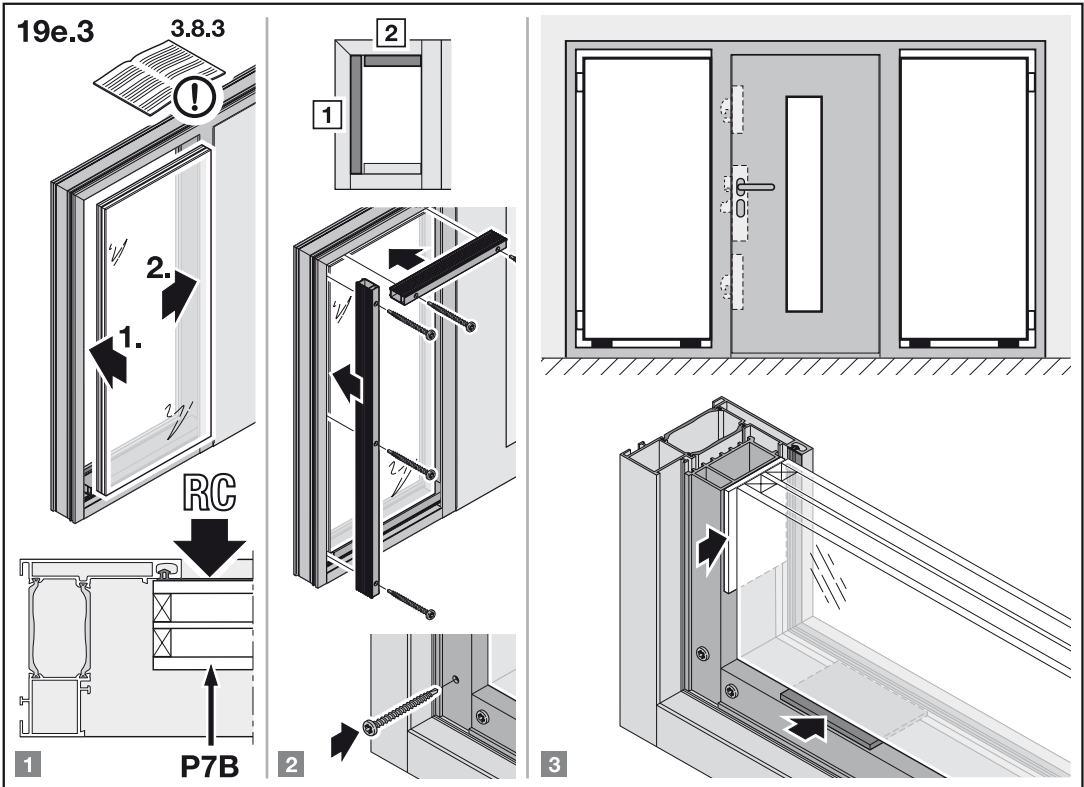

19e.5

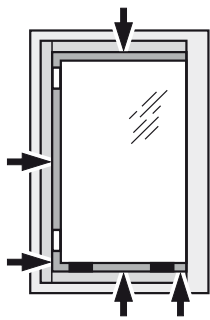

1

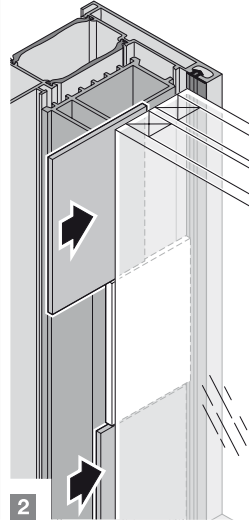
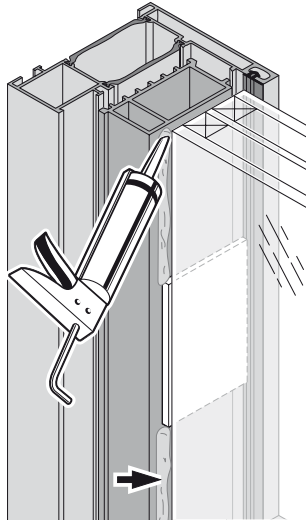

2

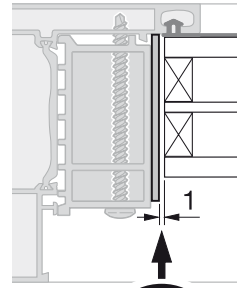

19e.6

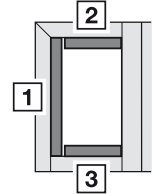

1

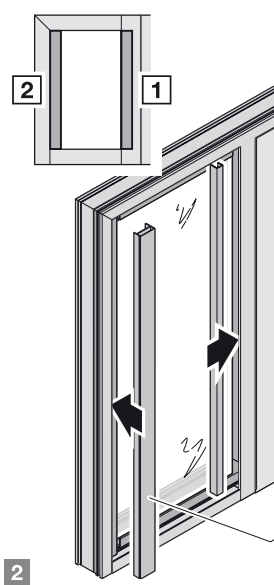
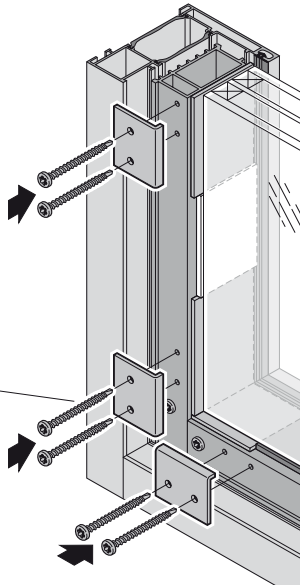

2

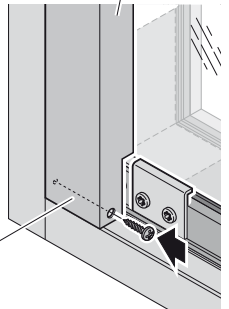
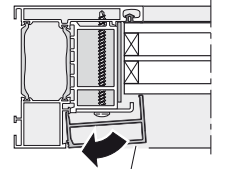

19e.7

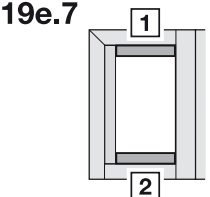

1

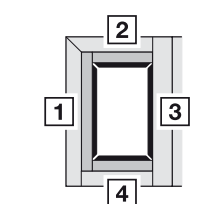
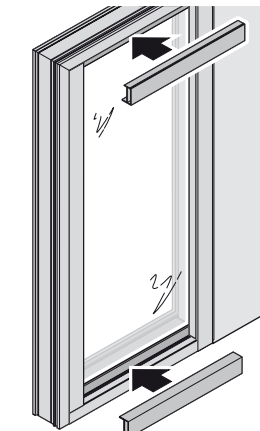
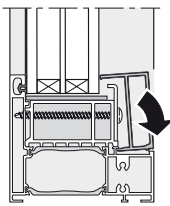

2

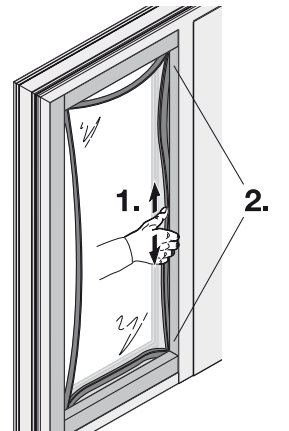
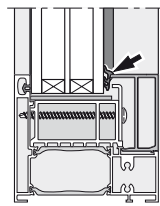

20

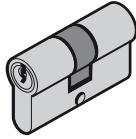

DIN EN 1303

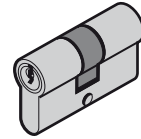

DIN EN 1303



21

