

SeceuroGlide LT

Installation Instructions

Always check on delivery that the order details are correct and the door is undamaged, especially **before removing any existing doors**.

Sequence of Installation & Contents

01. Pre-Installation and Component Check
02. Installation Options
03. Prepare the Opening
04. Prepare the Guide Rails
05. Fix Guide Rails & Axle Assembly
06. Tensioning the Anti-fall Back Spring
07. Fit Emergency Overrides
08. Curtain Adjustment (reducing height/making repairs)
09. Install the Curtain in the Guides, Attach to Axle & Fit Stops
10. Curtain Locking & Setting Motor Limit Switches
11. Installation of Box Supports
12. Commissioning
13. Technical Assistance
14. Notes

01. PRE-INSTALLATION AND COMPONENT CHECK

Check:

- i. Delivery note
- ii. Order sheet
- iii. Door dimensions / colour
- iv. Opening dimensions / clearances
- v. Components
- vi. Check for any damage to the guide rails or the outside roll of the curtain

Do not proceed further with the installation unless you are sure that the door is the correct size, and all components are present.

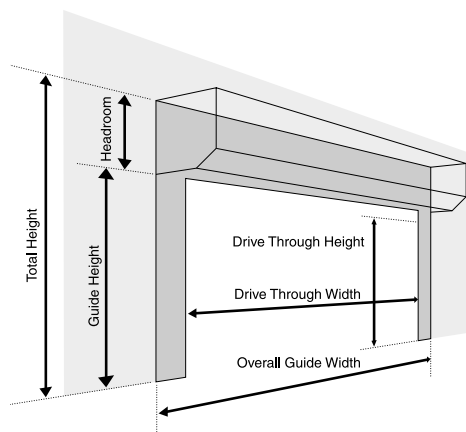

WIDTHS

Manufacturing Width = Over Guide Width
 Drive Through Width = Over Guide Width less 150mm for 75mm guides

HEIGHTS

Manufacturing Height = Guide Height
 Total Height = Guide Height + End Plate
 Headroom/End Plate up to 2.5m Guide Height = 300mm
 Drive Through Height = Guide Height less 100mm

- 01. Remote Control Unit
- 02. Motor (fitted into axle)
- 03. 70mm Octagonal Axle
- 04. 2 to 6 Pairs of Rings for Auto Lock Collars (fitted on axle)
- 05. Axle Cap or Spring (fitted into axle)
- 06. R/H End Plate
- 07. 2 to 6 Autolock Straps (3 elements)
- 08. 2 to 6 No.8 x 1/2" Pozi Pan Screws *
- 09. L/H End Plate
- 10. Guide Rails (UPH 75) 75mm or (UPH 250) 90mm
- 11. Brush Insert (fitted to guide)
- 12. Curtain
- 13. End Locks (fitted to curtain)
- 14. Bottom Slat (fitted to curtain)
- 15. Rubber Seal (fitted to bottom slat)
- 16. Override Eye *
- 17. 6 No. M8 X 21mm Penny Washers *
- 18. 2 No. Door Stops *
- 19. 2 No. M6 Nuts (inserted in bottom slat for securing stops) *
- 20. 10 No. 4mm X 8mm Rivets * (for securing endlocks)
- 21. 3 No. Cable Clips *
- 22. Crank Handle Clip *

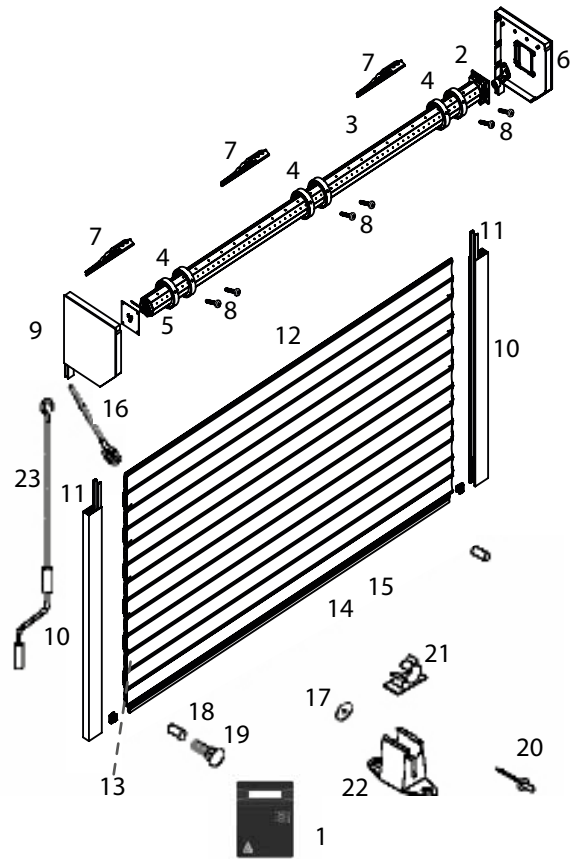

Recommended Fixings (not supplied)
 12 x 1" Self Tapping Screws for Steel
 12 x 2 1/2" Countersunk Screws for
 Masonry and Wood

*Supplied in Accessory Pack

Controls & Accessories

- 23. Crank Handle

Guides, axle assembly and the crank handle will be wrapped together in one bubble wrapped parcel and strapped together. The curtain is individually packed. A separate accessories box is packed with the installation and end user instructions, the attachment/locking arms, the accessory pack and a box containing the electrical items.

02. INSTALLATION OPTIONS

Internal Face Fit

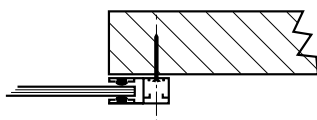

Reveal Fit

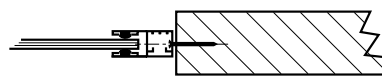

Undersize Face Fit

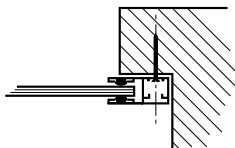

Fitted to existing or New Timber Frame

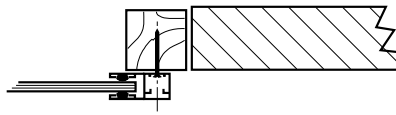

Combination of Face and Reveal Fit

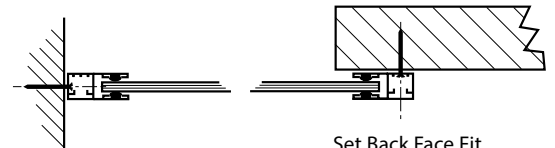

03. PREPARE THE OPENING

Check:

- i. Structure is sound/even & can carry the weight of the door
 - ii. No obstacles in fitting footprint eg. no sharp objects, pipes, cables, bumps etc. sticking out from the pillars, lintel or header to twist the guides, distort the fascia or catch on the curtain
 - iii. Floor is flat/level
- If necessary install a sub-frame to ensure secure, flush and level fixing (Recommended minimum 70 X 70 PAR).

04. PREPARE THE GUIDE RAILS

If the guides require cutting down refer to the 'Widths and Heights' information in Section 1. If face fixing where possible set the guide height at least 100mm above the structural opening height to maximise drive through height.

The top of the guide rails have been opened up to aid the movement of the door into and out of the guide rails. If you need to reduce the length of the guide rails you must cut from the bottom of the guide rails.

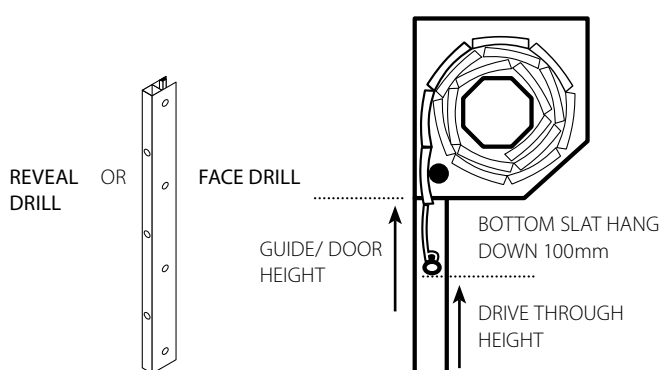

- i. Position guides
- ii. Drill guide fixing holes (min 4) 7mm pilot hole 13mm outer hole, avoid mortar joints and edges of bricks etc.

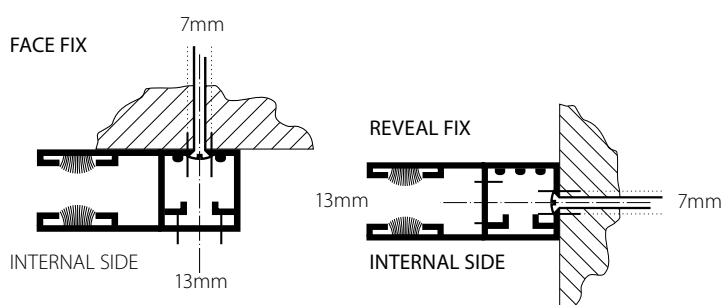

N.B. Guides are handed. If cutting guides cut excess length from bottom of guide.

05. FIX GUIDE RAILS & AXLE ASSEMBLY

N.B. Before positioning check that there are no sharp objects or bumps sticking out from the pillars, lintel or header to twist the guides or that will catch the door during operation.

If in doubt pack the guides and end plates out by at least 10mm.

- i. Slot end plate lugs into guides (see **Drawing A**) remembering the guides are handed
- ii. Position guides and end plates against opening
- iii. Hold or prop securely the assembly in position
- iv. Drill fixing holes (min 4 in guides and 2 in each end plate)
- v. Fix guides/end plates with minimum No. 12 x 21/2" countersunk screws (and plugs) to masonry/timber or 12 x 1" self tapping screws to steel.

N.B. Extreme care should be taken while manoeuvring the door into place to avoid the possibility of snapping the end plate lugs. It is imperative that fixings are put through the end plates into the wall as the aluminium lugs are not designed to carry the weight of the door.

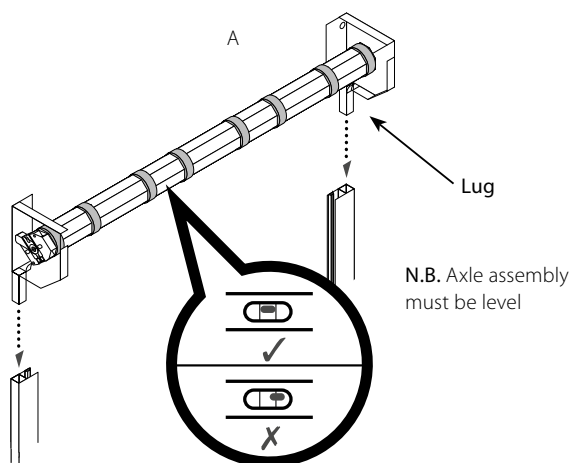

Check:

- i. Back faces of guides and end plates are flush and untwisted (see **Drawing B**)
- ii. Guides are vertical/parallel/same height

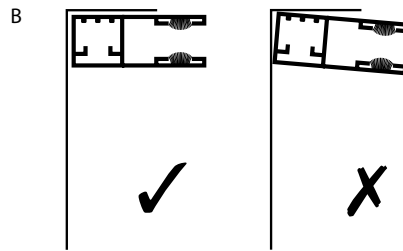

Installation of the Axle Assembly:

- i. For doors supplied with an un-assembled box only, fix the bracket to the end plate using the screws provided in the accessories kit.



Ensure that the open end of the bracket cup is facing towards the top of the end plate.

Anti-Fall Back Spring

- ii. Locate the anti-fall back spring in to the bracket fitted to the end plate.
- iii. Use the split pin provided in the accessories kit to secure the spring to the bracket.

Dummy End

- ii. Locate the dummy end in to the bracket fitted to the end plate.

If the dummy end appears to be too short, loosen the grub screw and extend the dummy end to the required length, then tighten the grub screw.



- iii. Fold the top tabs on the bracket round the bearing to secure the bearing.

- iii. Fasten the motor end of the axle, using the bracket supplied, to the other end plate using the screws provided and the prepared tapped holes in the end plate.

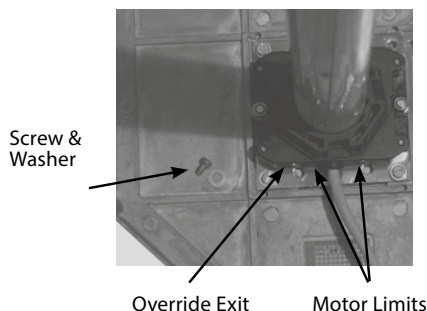

- v. Ensure that the collars are the correct way around (see **Drawing C**).
- vi. Secure motor power lead with cable clips so that it is tight against the end plate – (see **Drawing D**).
- vii. You must ensure that you allow for a drip loop in the motor cable to prevent water from running down the cable and into the motor. Spare cable ties can be attached to the motor cable to act as drip loop to prevent water entering the motor.

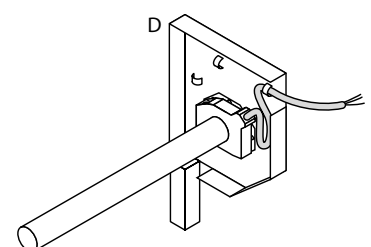
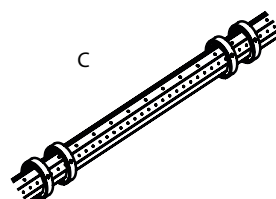

- iv. Ensure that the motor limits are facing down and that the override hole is towards the chamfered front end of the end plate.

06. TENSIONING THE ANTI-FALL BACK SPRING

If an anti-fall back spring has been supplied fitted in the axle you must now tension the spring as follows:

01. Connect the motor to either a test lead or the remote control.
02. Using the test lead rotate the axle in the close direction (see **Drawing G** and label on axle).
03. The number of turns required will be clearly stated on a label.
04. When complete the axle will be fully tensioned and will be ready for installation and attachment of the curtain in the fully closed position.
05. If the axle stops before it has completed the required number of turns the lower limit may need adjusting to allow the correct number of turns to be applied.

UP arrow is door closing, DOWN arrow is door opening.

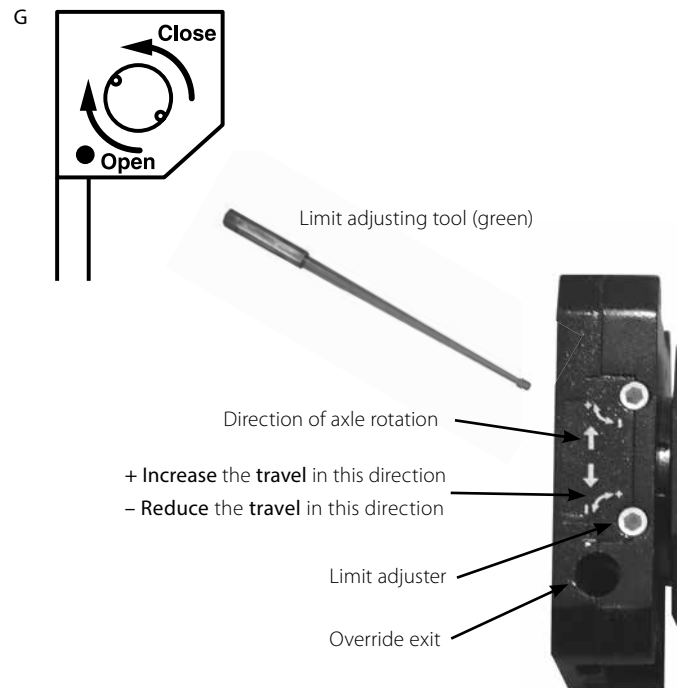

07. FITTING EMERGENCY OVERRIDES

The motor limits are accessible from two sides. This enables the motor to always be fitted to the end plate so that limits are facing down and so that the override is towards the front of the end plate.

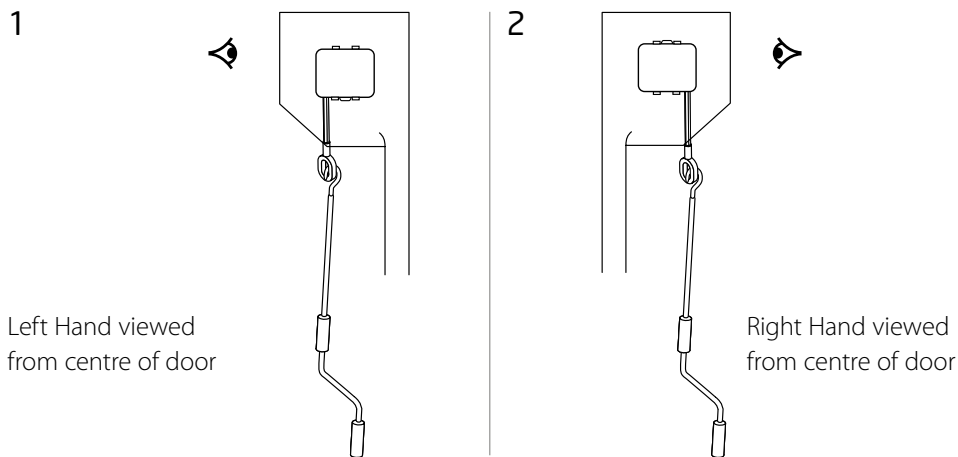

On a left hand door the motor cable will exit the motor vertically down.

On a right hand door the motor cable will exit the motor vertically up. You must ensure that you include a drip loop to prevent water from entering the motor.

This will ensure that you do not have to cut down the roller plate to enable the override eye to be fitted.

Possible Override Exit Options

- i. Drill hole for override eye through end plate flange
- ii. Remove the screw and the upper collar
- iii. Insert override eye in hole in motor adjacent to limit adjusters
- iv. Locate and tighten the upper and lower collars around the motor
- v. Insert and tighten the holding screw and washer from above
- vi. Hook crank handle in eye
- vii. Secure clear of shutter with crank handle clip

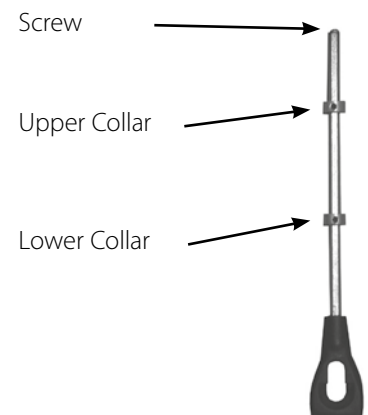

08. CURTAIN ADJUSTMENT (REDUCING HEIGHT/MAKING REPAIRS)

The curtain needs to be the correct height for the door to lock properly (if too tall remove slat(s) – If too short notify supplier).

Check you have the correct number of slats in the curtain for the guide height (particularly if you have shortened the guide height) and adjust the curtain accordingly.

Remove slat by carefully snipping ear off end lock before sliding out slat. Preferably take slats off from the top of the curtain to save having to remove and refit bottom slat. Either roll curtain out on a flat and protected surface such as the bubble wrap and/or cardboard packaging in which the curtain is delivered, or do as below.

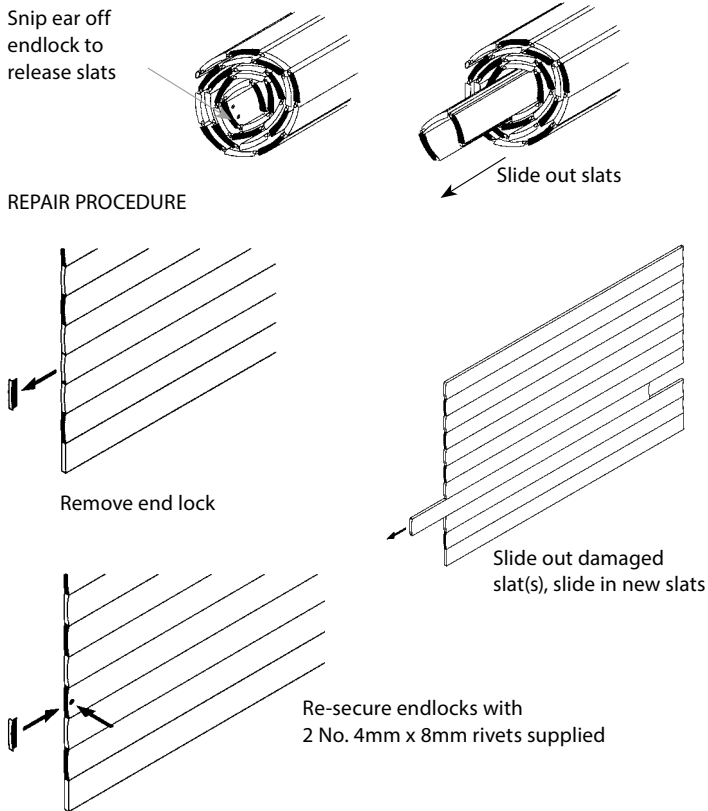

09. INSTALL THE CURTAIN IN THE GUIDES, ATTACH TO AXLE & FIT STOPS

- i. Check there are at least 2 pairs of autolock collars on the axle. They should all be fitted onto the axle in the same position (see **Drawing A**). One collar from the pair will have restricted movement due to fixing in the axle, this will be the positioning of the straps.
- ii. Lift coiled curtain up level with axle and feed bottom of curtain into guide (see **Drawing B**).
- iii. Slowly unroll curtain and gently lower onto a tool box or block (see **Drawing B**).

N.B. Do not allow the curtain to free fall over the axle as this will result in damage to the curtain.

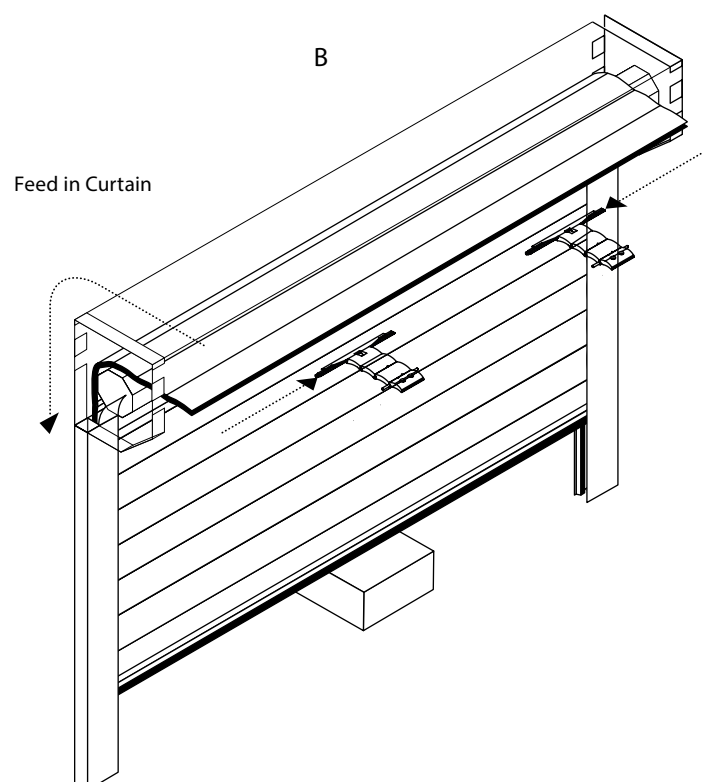
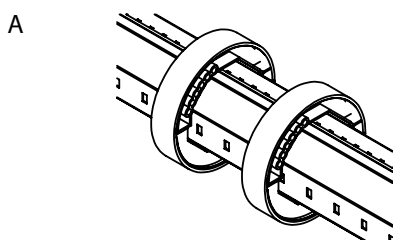

09. INSTALL THE CURTAIN IN THE GUIDES, ATTACH TO AXLE & FIT STOPS (CONTINUED)

Slide the autolock straps and attach the pins into each of the collars on the axle, ensuring they are pushed up to the collar that is fixed into the axle.

N.B. You must ensure the strap pins are fully engaged into the collars on the axle before fixing the second collar in place to prevent the product failing (see **Drawing C**).

Use the No.8 x 1/2" pozi pan screws supplied to fix the other collar in place (see **Drawing D**).

- iv. Use override to raise door sufficiently to remove toolbox/block. Ensure that the semi-circular curtain attachment bracket coils up flush with the collars (see **Drawing E**). Leave door in partially open position.

- v. Secure stops to captive nuts in the bottom slat with the bolts provided (see **Drawing F**). It is essential to fit the stops for health and safety reasons.

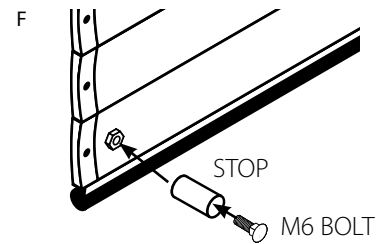
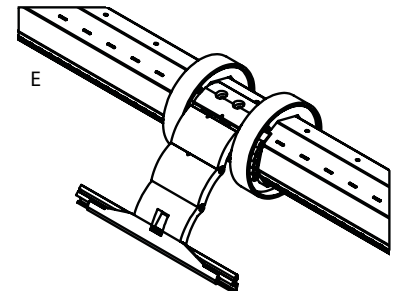
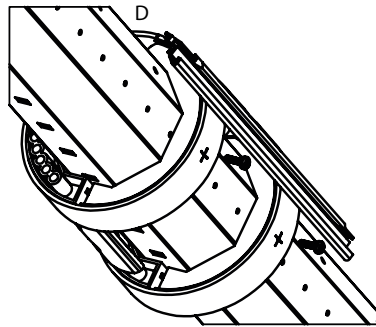
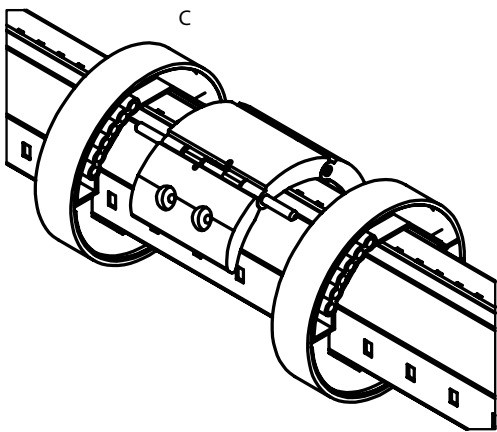

10. CURTAIN LOCKING & SETTING MOTOR LIMIT SWITCHES

The Roller Garage Door is manufactured with the curtain height to suit the length of guide supplied. The door will not lock down properly if the curtain is either too tall or too short. If the guide height has been adjusted on site, check that the top of the curtain is neither below the top of the guide nor more than one slat above (see **Drawings A & B**). Both limits require setting along with a final adjustment of the locking springs. **N.B. Incorrect setting of the limits risks damage to the motor, curtain and attachment devices.**

Which limit is up and which limit is down?

The up and down limit is determined using the direction arrows next to the limit adjusters and the direction of axle rotation to either close or open the door.

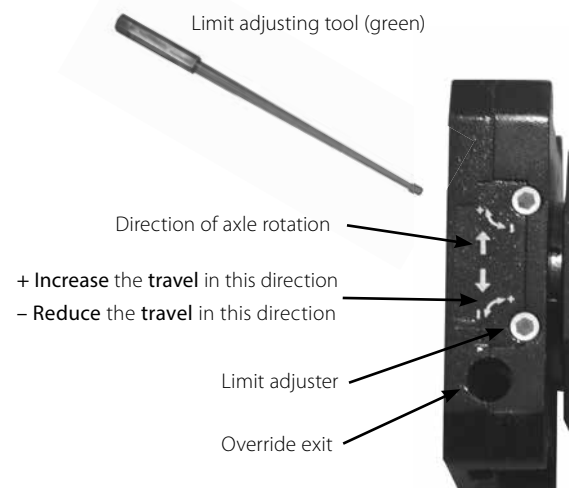
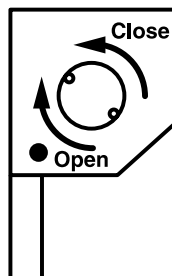

Closed/Down limit setting and locking spring adjustment

- i. Carefully close the door using either a motor test lead or the remote control unit so that the curtain is fully down and the top slat is pushed forward.

The autolock strap should be positioned with a slight bend which locks the collar out (see **Drawings B & C**).

- ii. Turn the down limit in the '+' direction to **increase** the **travel** of the door.
Turn the down limit in the '-' direction to **reduce** the **travel** of the door.

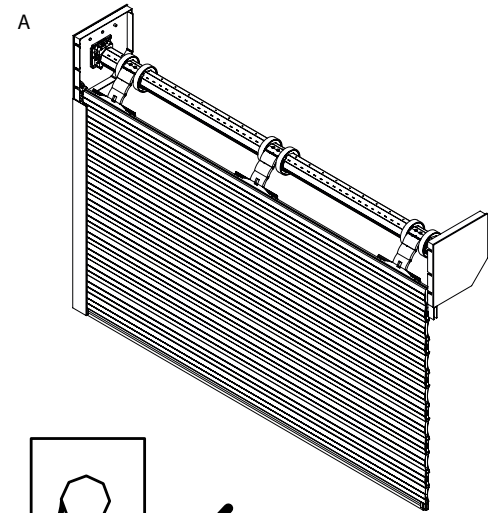

Open/Up limit setting

- iii. Carefully open the door using either a motor test lead or the remote control unit so that the curtain is fully open.

- i. Turn the up limit in the '+' direction to **increase** the **travel** of the door.
Turn the up limit in the '-' direction to **reduce** the **travel** of the door.

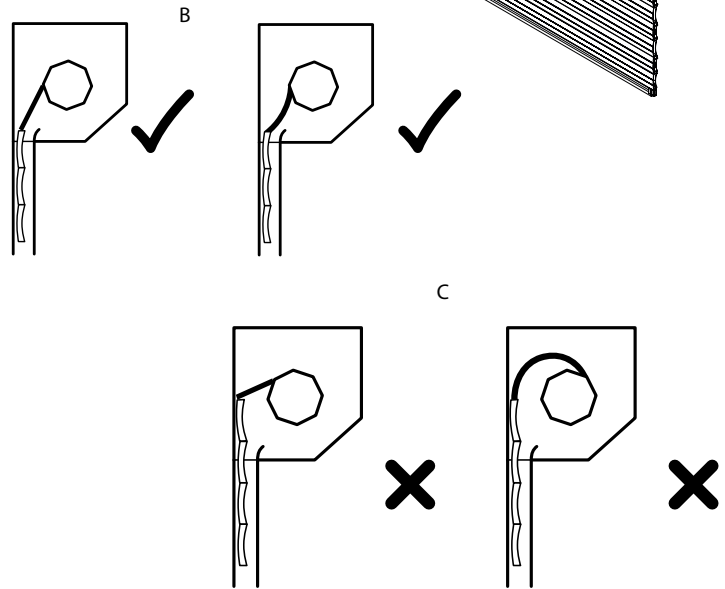

11. INSTALLATION OF BOX SUPPORTS - OPTIONAL EXTRA FOR HALF BOX OR FULL BOX

The box supports you have been supplied need to be riveted to the fascia to hold them in place.

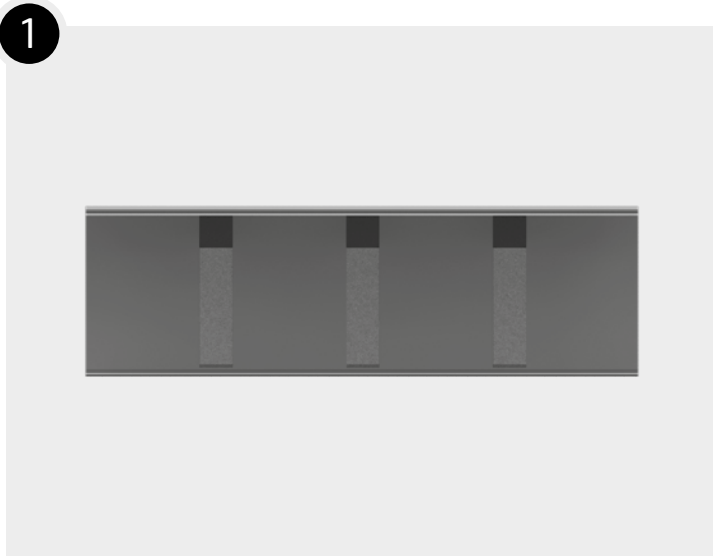

First fix the fascia in place then position the box supports within the fascia with equal distances in between each support.

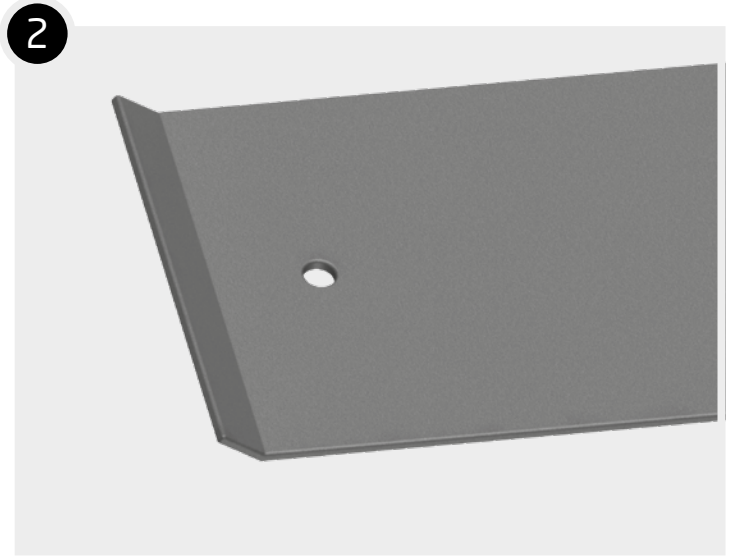

The box supports are supplied with a hole on the top front edge.

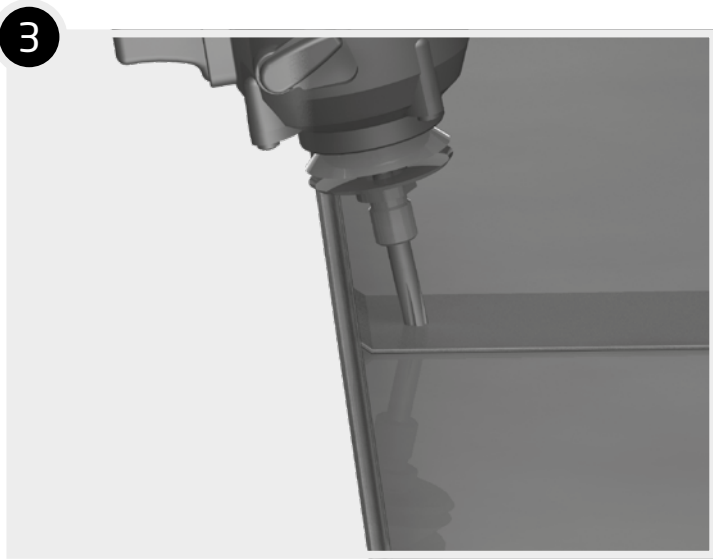

Drill a hole with a 4.2mm drill bit through this hole and the fascia.

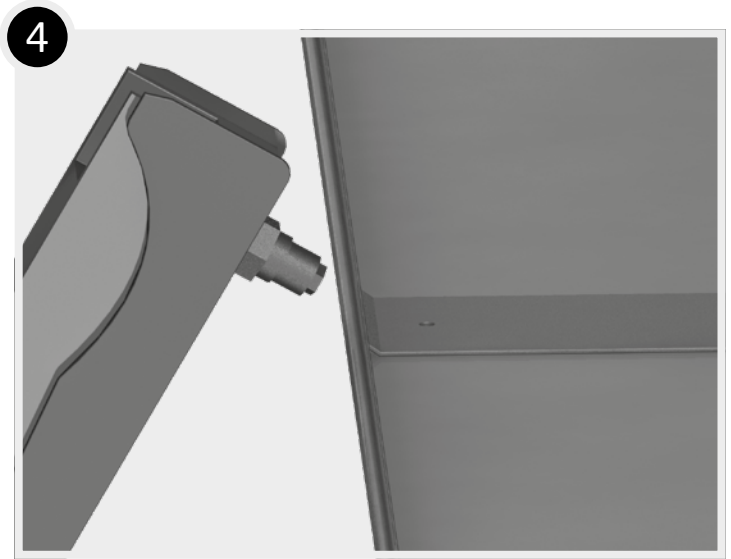

Fasten the box support to the fascia using a 4 x 8 rivet.

12. COMMISSIONING

Final Checks

- i. Remove any protective plastic coverings.
- ii. Wipe curtain & guides with damp cloth.
- iii. Touch-up any small scratches.
- iv. Check all electrical & operating equipment is installed and functioning correctly (especially the safety edge) and complete CE marking label and paperwork.
- v. Check direction handle needs winding to open door and fit appropriate label supplied to crank handle.

N.B. Check the front of the curtain to make sure that it is not rubbing on the lintel.

The manual override will not function after the door is operated by remote control, until the power to the motor has 'timed out'.

This will take a few moments to occur.

If you wish to demonstrate the manual override immediately after opening the door press either the stop button on the handset or simulate a power cut by switching off the power to the Control Unit.

Upon completion it is your responsibility to train the customer how to operate the door correctly and safely and provide them with the operating and maintenance instructions supplied.

13. TECHNICAL ASSISTANCE

If you require any on site technical assistance including repair or maintenance queries please call **01524 772400** or email technical@swsuk.co.uk

Control unit set up instructions are provided in the control panel accessory box along with the control unit and you can also access them digitally using this QR code or link:



www.sws.co.uk/fitting-instructions

