

SeceuroGlide Manual

Installation Instructions

Always check on delivery that the order details are correct and the door is undamaged and especially **before removing any existing doors**.

Sequence of Installation & Contents

01. Pre-Installation and Component Check
02. Prepare the Opening
03. Installation Options
04. Prepare the Guide Rails
05. Fit End Plates and Guides
06. Install Axle Assembly
07. Install the Curtain in the Guides, Tension the Spring & Attach Curtain to Axle, Preparing the Guide Rails for the Lock Bar
08. Curtain Adjustment (reducing height / making repairs)
09. Commissioning
10. Technical Assistance
11. Notes

PLEASE NOTE

These instructions have been produced assuming that this door will be installed by two engineers to assist with the tensioning of the spring.

01. PRE-INSTALLATION AND COMPONENT CHECK

Check:

- i. Delivery note
- ii. Order sheet
- iii. Door dimensions / colour
- iv. Opening dimensions / clearances
- v. Components
- vi. Check for any damage to the guide rails or the outside roll of the curtain

Do not proceed further with the installation unless you are sure that the door is the correct size, and all components are present.

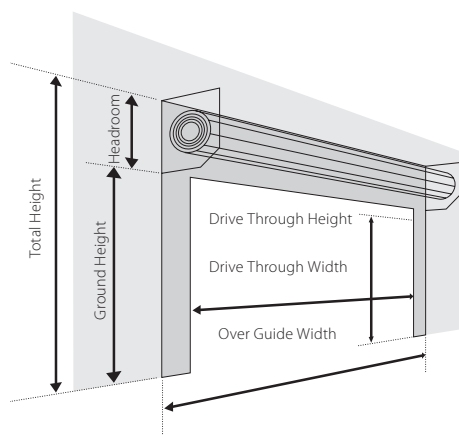

WIDTHS

Order Width = Over Guide Width

Drive Through Width = Over Guide Width less 150mm for 75mm guides

HEIGHTS

Order Height = Guide Height

Total Height = Guide Height + End Plate

Headroom/End Plate
up to 2.3m Guide Height = 300mm

Drive Through Height = Guide Height less 105mm

MANUAL ROLLER GARAGE DOOR COMPONENTS

01. Pull Down Cord *
02. Spring (fitted into axle)
03. 102mm Round Axle
04. Locking Collars (fitted to axle 6 No. up to 2.5m, 8 No. up to 3m)
05. Dummy End or Second Spring
06. Attachment Arm * (3 – 4 No.)
07. R/H End Plate *
08. L/H End Plate *
09. Roller Bracket Bearing *
10. Guide Rails
11. Brush Insert (fitted to guides)
12. Curtain
13. Locking / Handle Slat (fitted to door curtain 10th slat up)
14. Polyester Webbing Strip (fitted to curtain)
15. 8 X 1/2 Flange Head Self Tapping Screw (securing webbing to curtain)
16. Bottom Slat (fitted to curtain)
17. Rubber Seal (fitted to bottom slat)
18. Stop Brackets * (2No. for fitting to bottom slat)

* Supplied In Accessory Pack.

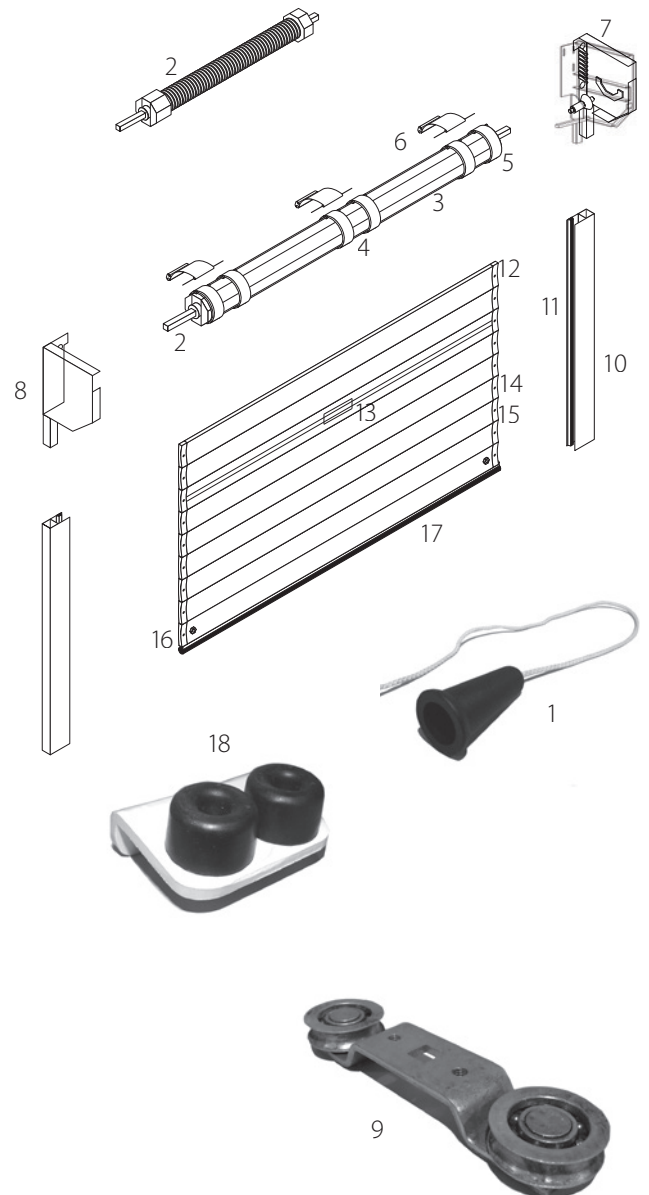

Recommended Fixings (not supplied)
 12 x 1" Self Tapping Screws for Steel
 12 x 2 1/2" Countersunk Screws for
 Masonry and Wood

02. PREPARE THE OPENING

Check:

- i. Structure is sound/even & can carry the weight of the door (curtain weight is approximately 5kg/m² and allow an extra 15kg for the guides, end plates and axle assembly).
- ii. No obstacles in fitting footprint e.g. no sharp objects, pipes, cables, bumps etc. sticking out from the pillars, lintel or header to twist the guides, or catch on the curtain

- iii. Floor is flat/level

If necessary install a sub-frame to ensure secure, flush and level fixing. (Recommended minimum 70 X 70 PAR)

03. INSTALLATION OPTIONS

Internal installation only

The garage door must be installed internally

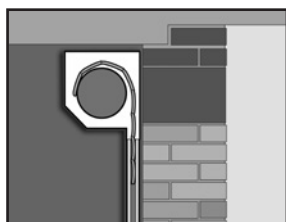

Face fit

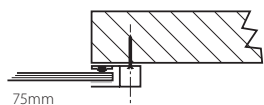

Reveal fit

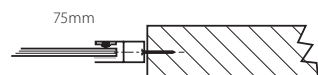

Combination of face and reveal fit

In this situation one guide rail is reveal fitted and the other guide rail is face fitted.

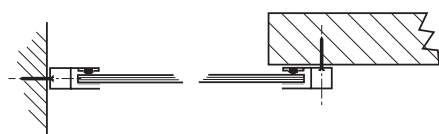

Undersize face fit

In this situation the guide rails are face fitted but they will protrude into the opening.

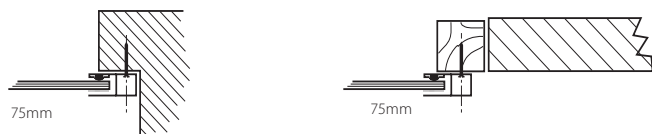

Minimum number of fixings per guide rail

Due to the additional forces that a manually operated door is subjected to we recommend that you use the minimum number of fixings stated above.

Height of guide rails	Minimum no. of fixings required
Less than or equal to 1000mm	3
1001mm to 1500mm	4
1501mm to 2300mm	5

Proximity of holes to the end of the guide rails

The first and last holes at the ends of the guide rails must be drilled 120mm from the ends of the guide rails.

Minimum number of fixings per end plate

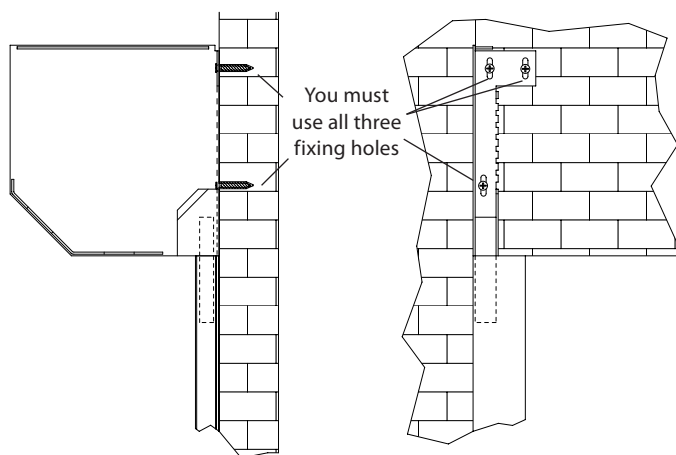

! All three fixing holes in each end plate must be used

04. PREPARE THE GUIDE RAILS

If the guides require cutting down refer to the information at the start of Section 1 and also Section 8 for reducing the curtain height. If face fixing where possible set the guide height at least 105mm above the structural opening height to maximise drive through height.

- i. Position guides
- ii. Drill guide fixing holes 7mm pilot hole 13mm outer hole (min 4) avoid mortar joints and edges of bricks etc.

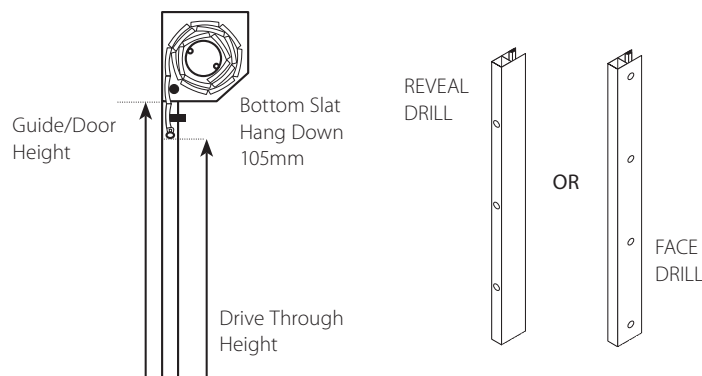
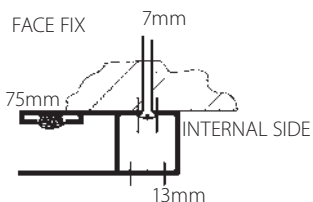
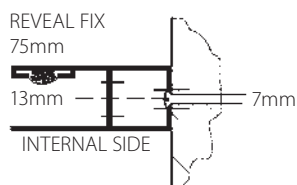

05. FIT END PLATES AND GUIDES

N.B. When fitting doors it is important that you check that the lintel does not bow inwards or have any projections that may catch on the curtain. If in doubt pack the guides and end plates out by at least 10mm.

Assemble Guide Rails & End Plates

- i. Attach the short sections of webbing (supplied in the accessory box) to the end plate fixing plate
- ii. Slot end plates into guides – see **Drawing A**
- iii. Position guides and the end plates against/in opening
- iv. Hold or prop securely in position

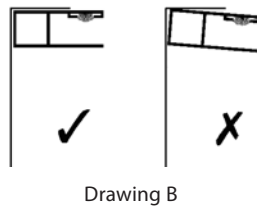
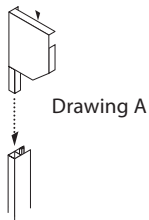

Before proceeding any further check:

- a) Back faces of guides and end plates are flush and untwisted – see **Drawing B**
- b) That the distance between the outside edges of the guides is 90mm more than the curtain width
- c) Ensure that the distance between the outer edges of the end plates is equal to the stated overall width of the door.

Fix Guide Rails & End Plates

- v. Drill fixing holes
- vi. Fix guides/end plates with minimum No. 12 x 21/2" countersunk screws (and plugs) to masonry/timber or 12 x 1" self tapping screws to steel.
- vii. Ease open top of guides, slots will have been cut in to the top of the guide rails to assist with this – see **Drawing C**

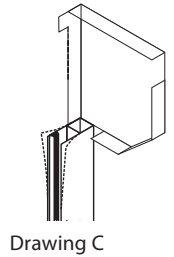

06. INSTALL AXLE ASSEMBLY

Before proceeding any further check:

- a) Guides are vertical / parallel / and not twisted – see **Drawing B** (above)
- b) That the distance between the outside edges of the guides is 90mm more than the curtain width
- c) Ensure that the distance between the outer edges of the end plates is equal to the stated overall width of the door.

- i. Place the roller bracket bearings on to the square bars protruding from the ends of the axle assembly and secure in place using the R clips provided – see **Image D**

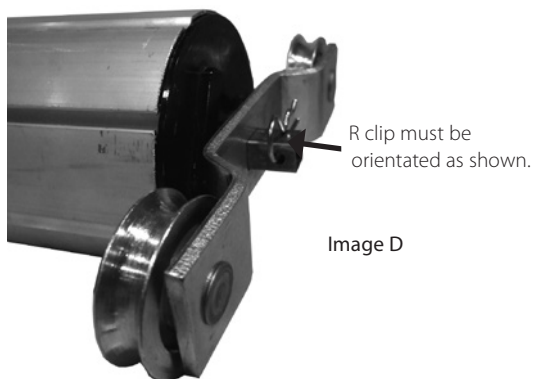

- ii. The number of axle turns required to tension the spring is shown on a label attached to the left hand end plate.

Before proceeding any further check: It is important that you make a note of the number of turns required before you offer up the axle assembly as this number will determine the axles orientation when it is loaded in to the end plates.

Full Turns

If the number of turns is a whole number (for example 8 turns) the axle and its collars must be orientated as **Drawing E**.

Drawing E

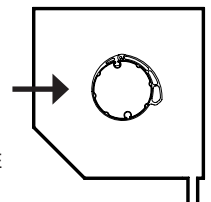

Half Turns

If the number of turns is a half number (for example 8 1/2 turns) the axle and its collars must be orientated as **Drawing F**.

Drawing F

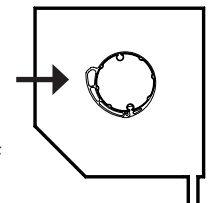

- iii. Offer up the axle assembly to the end plates and slide the roller brackets in to the tracks.

- iv. Fit the two bolts supplied to prevent the axle assembly from sliding back out of the end plates.

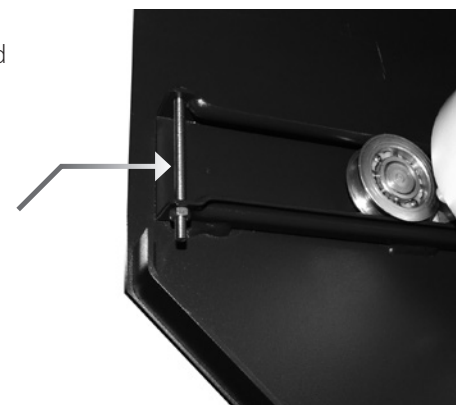

07. INSTALL THE CURTAIN IN THE GUIDES

- i. Check that there are at least 3 pairs of collars on the axle and that they are facing the correct direction – see **Drawing A**.

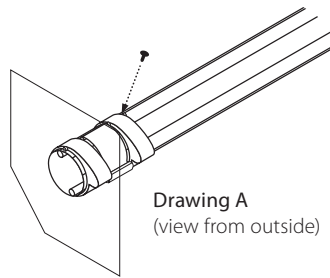

Wrap bubble wrap around the axle to protect the curtain and continue with remaining instructions.

- ii. Lift coiled curtain up level with axle and feed bottom of curtain into guide
- iii. Slowly unroll curtain and gently lower onto a tool box or block approximately 250mm tall

N.B. Do not allow the curtain to free fall over the axle as this will result in damage to the curtain

- iv. Slide the attachment arms on to the top slat
- For the above see **Drawing B**

Drawing B
(view from inside)

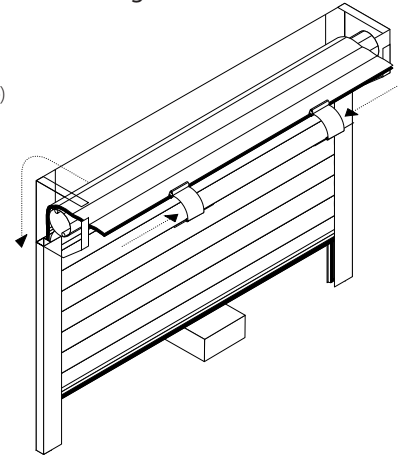

TENSION THE SPRING & ATTACH CURTAIN TO AXLE

- i. Add 5 (or 5 1/2 if starting from half position) turns of tension to the spring by rotating the axle in the close direction – see **Drawing C**
- ii. Position unattached end of attachment arm so that the fixing bolt line up with locating holes in the two collars and slide collars together making sure **Drawing C** pre-positioned collar is tight against rivet – see **Drawings D & E**

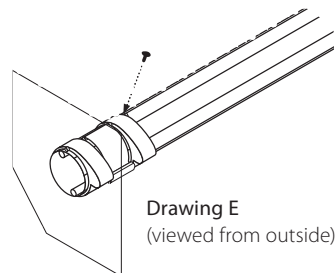
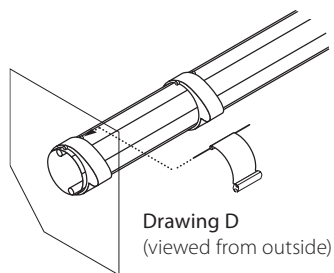
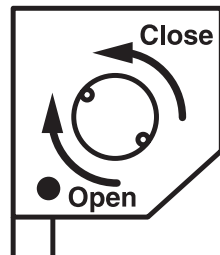

- iii. Fix 'loose' collars in position by placing a 4.8mm x 9.3mm x 12mm pop rivets tight up against the outside edge of the collar in the rounded cut-out in the axle. There is no need to drill a hole

N.B. Make sure rivets are secure

- iv. – Open the door so that the entire curtain is coiled around the axle.
- Lift the curtain out of the guide rails and rotate the curtain, while holding the bottom slat to keep the coil tight.
- Rotate the axle in the close direction to complete the number of turns required which is stated on the end plate label. For example if 8 turns are required another 3 complete turns of the axle will be required.
- v. Lower the curtain back in to the guide rails. If the spring tension has been set correctly:
- The door should not slide down under its own weight
- When the door is fully closed the spring should not try to significantly lift the door back up
- vi. If the tension is not correct that a whole turn of tension can either be added or removed as required.
- vii. Lower the door to a suitable position for attaching the bottom slat stops.
- viii. Secure stop brackets to the bottom slat with M6 bolts, M6 Nylock Nuts and washers provided
- N.B.** It is essential to fit stops for health and safety reasons

PREPARING THE GUIDE RAILS FOR THE LOCK BAR

- ix. Lower the door to the fully closed position. Using a pencil mark on the guide rails the height where the lock bar enters the guide rails.
- x. Raise the curtain to the fully open position. Using the pencil marks drill a 13mm hole in each guide rail for the lock bar in the centre of the guide rail. The holes do not need to go all the way through the guide rail.

For most installations the guide rail marking will be done on the inside of the garage and the installer will push the curtain towards the outside.

During normal operation the door will be unlocked from the outside and the user will push the curtain towards the inside.



To allow for this the 13mm hole drilled for the lock bar should be extended into a horizontal slot.

The hole must be deburred to ensure the burrs do not catch on the curtain.

08. CURTAIN ADJUSTMENT (REDUCING HEIGHT / MAKING REPAIRS)

If the door needs to be reduced in width it will need returning to the supplier.

The curtain needs to be the correct height for the door to operate correctly (if too tall remove slat(s) – If too short notify supplier).

The optimum curtain height finishes midway up the end plate.

Check you have the correct number of slats in the curtain for the guide height (particularly if you have shortened the guide height) and adjust the curtain accordingly.

Curtain height =

- Curtain slats
- + Extruded top slat
- + Bottom slat

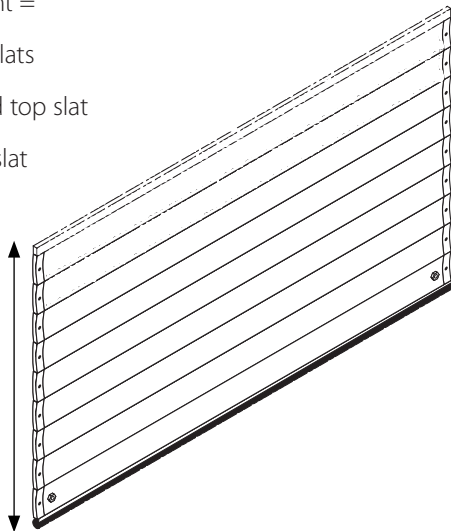

- i. Roll out the curtain on a flat and protected surface, such as bubble wrap and/or cardboard packaging in which the curtain was delivered.
- ii. Unscrew webbing from every slat which needs to be removed or replaced, gently lifting the webbing away from the surface of the slat.

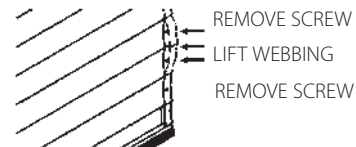

- iii. Slide out damaged slats and replace with new slats. Press down webbing and screw to the new slat.

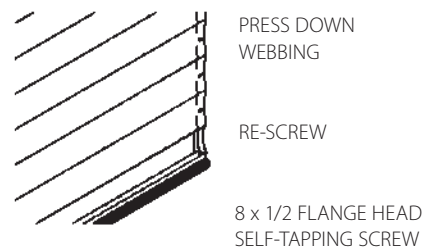
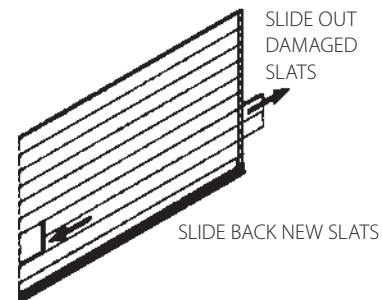

- iv. If the number of slats has been reduced, trim the webbing accordingly and carefully melt the cut ends to prevent fraying.

09. COMMISSIONING

Final Checks

- i. Remove any protective plastic coverings
- ii. Wipe curtain & guides with damp cloth
- iii. Touch-up any small scratches
- iv. If required the optional pull down cord can be attached to one of the stop brackets to assist with closing the door.

N.B. Check the front of the curtain to make sure that it is not rubbing on the fascia etc.

Upon completion it is your responsibility to train the customer how to operate the door correctly and safely and provide them with the operating and maintenance instructions supplied.