

ИНСТРУКЦИЯ ПО МОНТАЖУ

Ворота секционные гаражные
с пружинами растяжения

Русский

INSTALLATION MANUAL

Sectional garage doors
with tension springs

English

MONTAGEANLEITUNG

Der Garagen-Sektionaltore mit Zugfedern

Deutsch

INSTRUCTION DE MONTAGE

Portes sectionnelles de garage
avec les ressorts de traction

Français

NÁVOD K MONTÁŽI

Vrata sekční garážová

Český

INSTRUKCJA MONTAŻU

Bramy garażowe segmentowe

Polski

MONTAGE HANDLEIDING

Garage sectionaaldeuren

Nederlands

ASENNUSOHJE

Poikkipinta autotallin ovi

Suomi

MONTAGEVEJLEDNING

Garageporte

Dansk

ІНСТРУКЦІЯ ПО МОНТАЖУ

Ворота секційні гаражні

Український

1. GENERAL INFORMATION

Correct mounting of sectional doors is an essential requirement for reliable and long-term operation of the doors.

The installation manual contains the description & procedures and their recommended sequence while installing the doors.

All requirements and procedures concerning door installation must be strictly observed.

The contents of this document cannot serve as the basis for legal claims. Alutech/Günther reserves the right to make amendments and additions to improve the sectional door design and installation procedures.

2. SAFETY MEASURES

Installation of doors must be performed by qualified installers only. The installers must have knowledge of door design and technological stages of installation procedures by preferably passing through a training programme and understanding of the safety measures and compliance with HSE requirements.

3. REQUIREMENTS FOR OPENINGS

Openings prepared for door installation must meet the following requirements:

- the openings must be of square or rectangular shapes.
- the opening surfaces must be plain and smooth to affix the door frame;
- the deviation of walls, lintel and ceiling from vertical and horizontal alignment must not exceed 1,5 mm per metre and must not be more than 5 mm in the overall width or height;
- there must be enough room for door installation, free of building obstructions, heating pipes, ventilation, etc.

4. RULES FOR INSTALLING THE DOOR FRAME AND TRACKING SYSTEM

- Door frame must be fixed symmetrically to the vertical axis of an opening;
- Vertical door frame profiles must be fixed vertically;
- Vertical door frame profiles must abut flush with walls. Gaps up to 5mm are acceptable, but they must be packed flush by strips behind the fixing points;
- Diagonals measured at the end points of horizontal track profiles must not differ by more than 2 mm;
- A door must be securely fixed for safe operating and resistance to wind loading movement

Type of fixings are described below based on the material construction of the walls:

- anchors or rawplug anchors are utilised for fixing a door to a wall made of concrete, solid bricks, expanded-clay concrete, natural stone or other similar materials;
- extended rawplug anchors (160 mm long) for fixing a door to a wall made of lightweight cellular concrete, air bricks, shell limestone. External diameter of an anchor should be 10 mm.
- self-tapping screws of 6,3 mm or 8 mm external diameter must be used for fixing a door to metal constructions.
- To ensure the reliable fixing of a door to the walls it is necessary to install steel flat washers under screw heads or nuts. Washers should have the external diameter of 24...30 mm, and a thickness – 1,6 ...2,0 mm.

Screws must be produced from steel with anti-corrosion coating not less than 9 microns thick. Strength class is not less than 5.6.

All fixings must be corrosion resistant.

5. DRILLING

Depending on the material from which walls are made, the following methods of drilling for door fixings are recommended:

- drilling without hammer action is recommended for making holes in lightweight cellular concrete, air bricks, shell limestone, as well as for metal constructions;
- drilling with light hammer action is recommended for making apertures in solid bricks;
- full hammer action is recommended for walls made of concrete (density of more than 700 kg/m³) and natural stone.

Drilling depth must be greater than anchor length by at least the diameter of the screw. Diameter of drilled holes must not exceed rawplug anchor manufactures recommendations. The holes must be cleaned from dust and stone particles.

6. DOOR INSTALLATION

Before installing a door, the floor and the opening must be completely prepared and all building work completed.

It is necessary to provide proper water drainage within the floor, as well as ventilation of the premises. If any building works are being conducted in the premises while a door is being installed, the door must be protected from splatter, concrete, plaster, stone, aggressive substances (acids and alkali), paint, or impact etc.

No adaptations or changes must be made to the door design.

- Do not remove and change elements and parts of a door. Use only original parts supplied by the door manufacturer.
- Do not add additional items on a door leaf. Springs have been balanced to the original door leaf weight. Additional elements can overload the springs, which adversely affects the balancing system and can result in door breakage.

Before door leaf is installed it is necessary to take off the protective film around the holes for handles, locks, hinges and at the ends of panels from outside, where the door leaf meets with the top and side sealing (protective film should be taken off 50...100 mm from side caps).

While installing a motor follow the door and motor manufacturers' instructions. Use only original connecting parts supplied by the manufacturer.

Strictly follow all procedures detailed in the pictures in sequence to perform a technically correct installation.

To ensure smooth and noiseless operation of roller spindles in brackets and hinge pin connections lubricate them with consistent (flexible) grease. Do NOT lubricate door tracks, they are designed to operate without.

7. FINAL INSPECTION AND TESTING OF DOOR

After having completed the installation, remove the protective film from the panels. Clean any dirty parts of the door. The cleaning should be done by sponge soaked with water or non-aggressive liquids.

For window cleaning it is possible to use cleaning fluids for plastics. The fluids must be neutral to acrylic or polycarbonate. Do not use abrasive cleaning substances or substances for window cleaning containing solvents.

After having installed a door, check the operation of locking devices and programming of the motor.

Door operation should be tested by five open/close cycles. For additional automated functions the door should be tested additionally in all programmed modes.

All the film must be taken off as soon as installation is over.

8. HAND OVER OF THE COMPLETED INSTALLED DOOR

A hand over to a Client is recommended in the following way:

- installer or a company representative demonstrates the full operation of a door;
- maintenance documentation is completed and passed to the client.

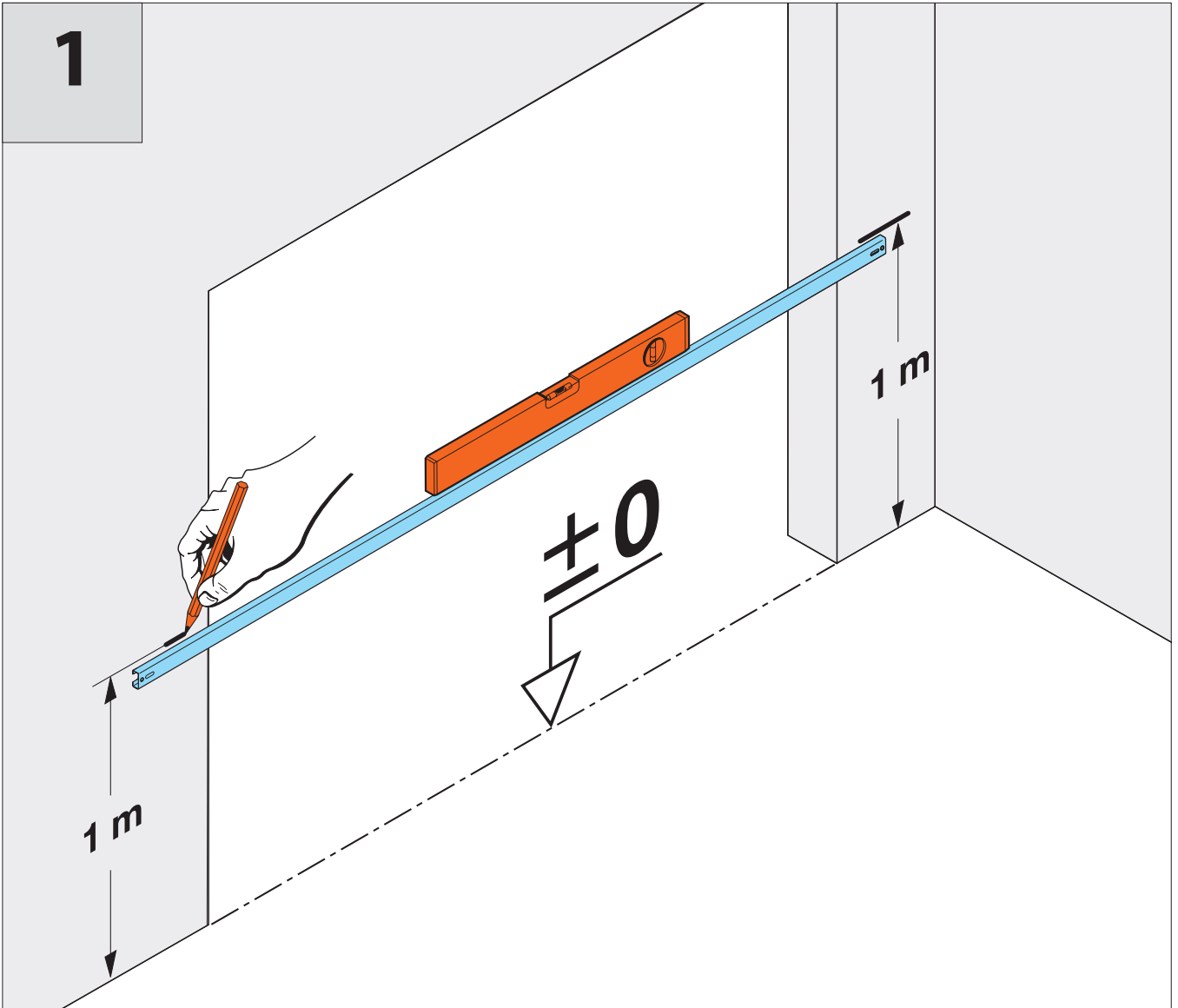
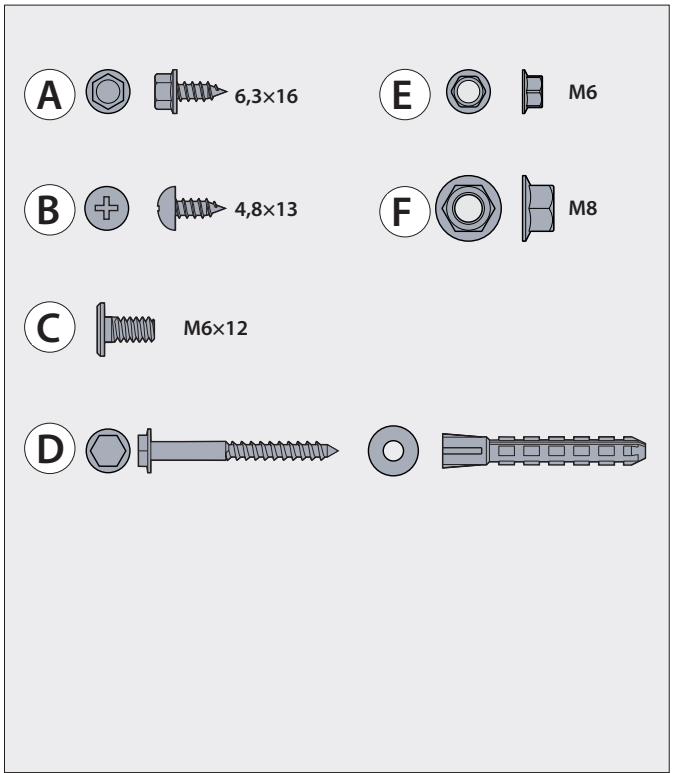
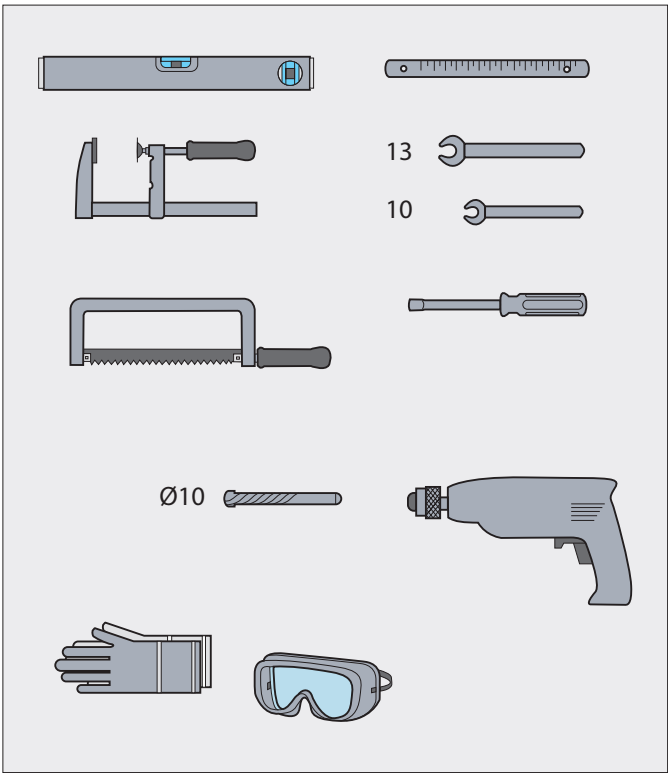

2

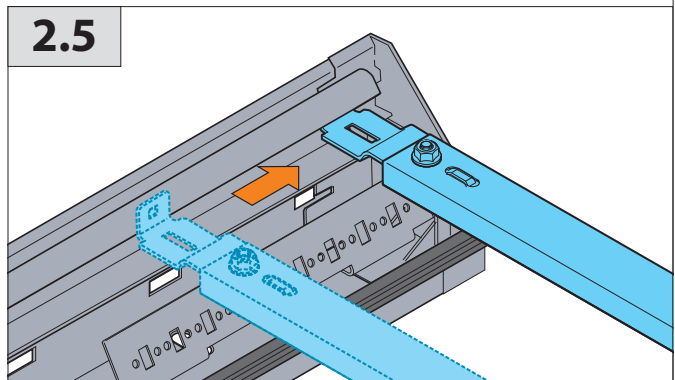
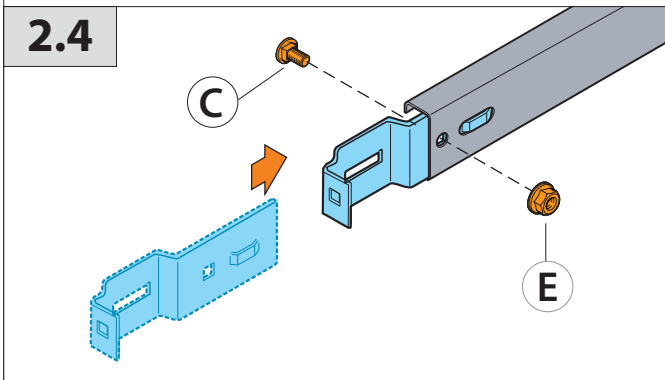
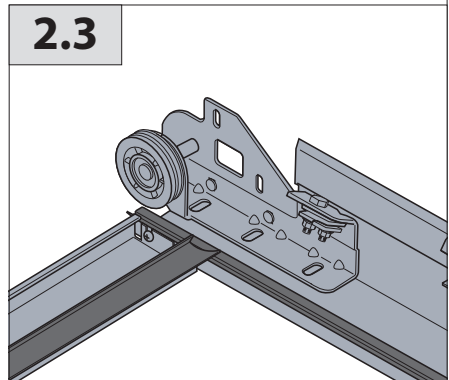
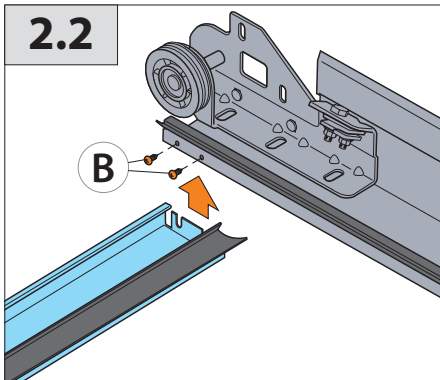
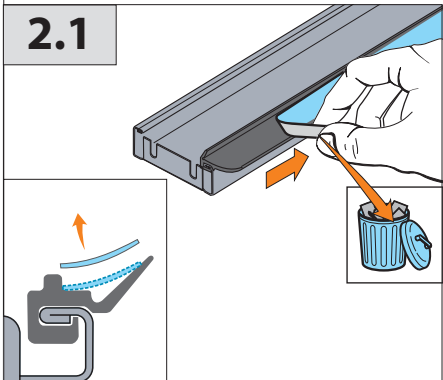
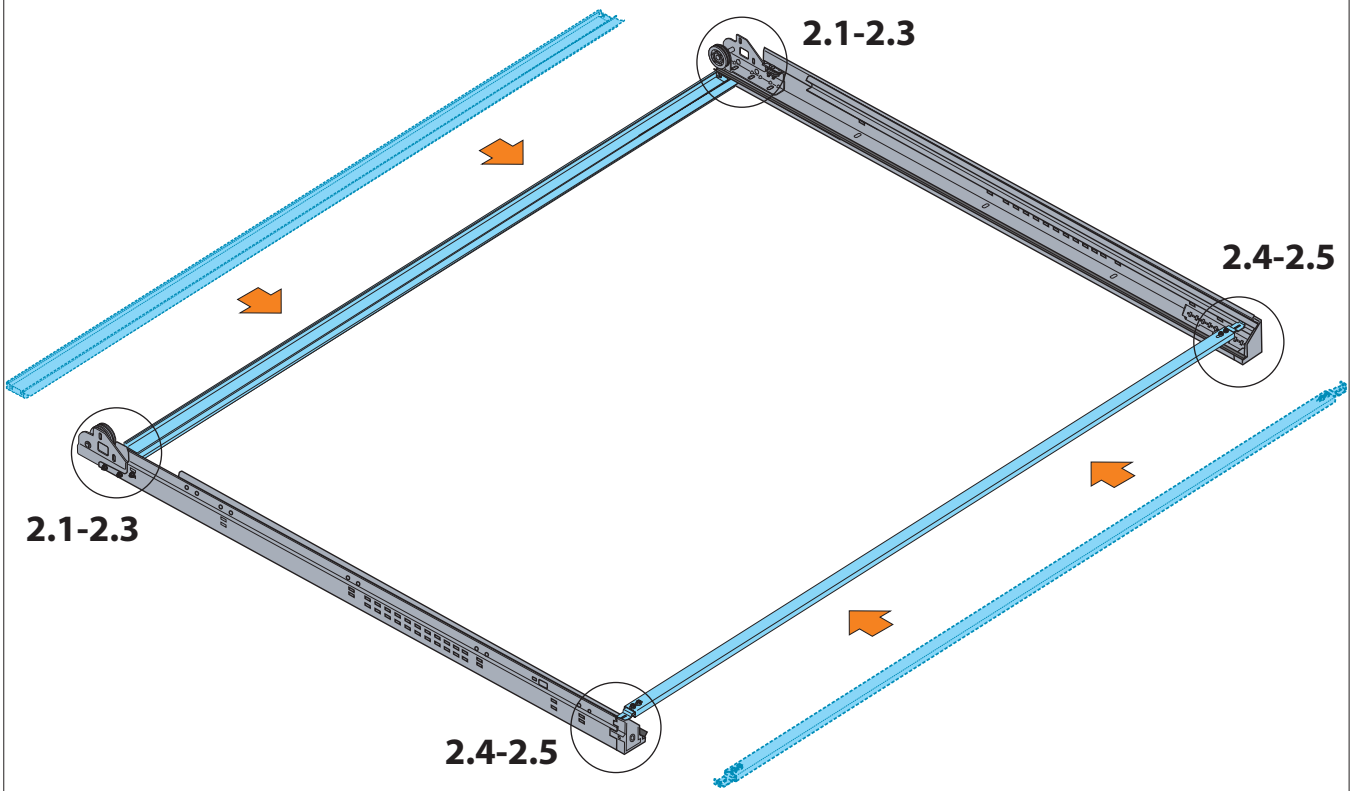

3

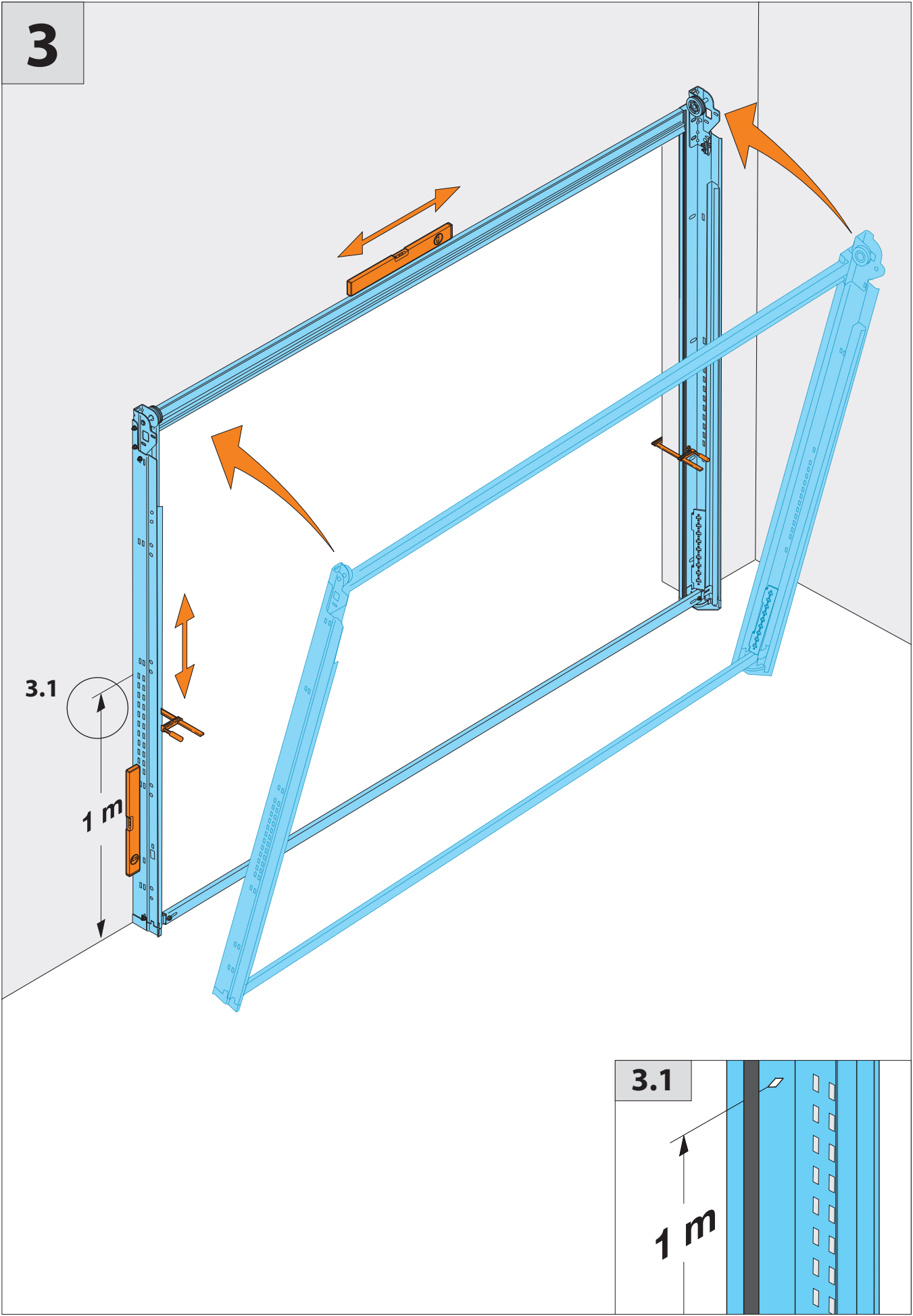

4a

4a.1

< 90

4a.2

4a.3

4a.4-4a.5

D

4a.1

4a.3

4a.4-4a.5

4a.1

D

4a.2

4a.3

E

D

4a.4

4a.5

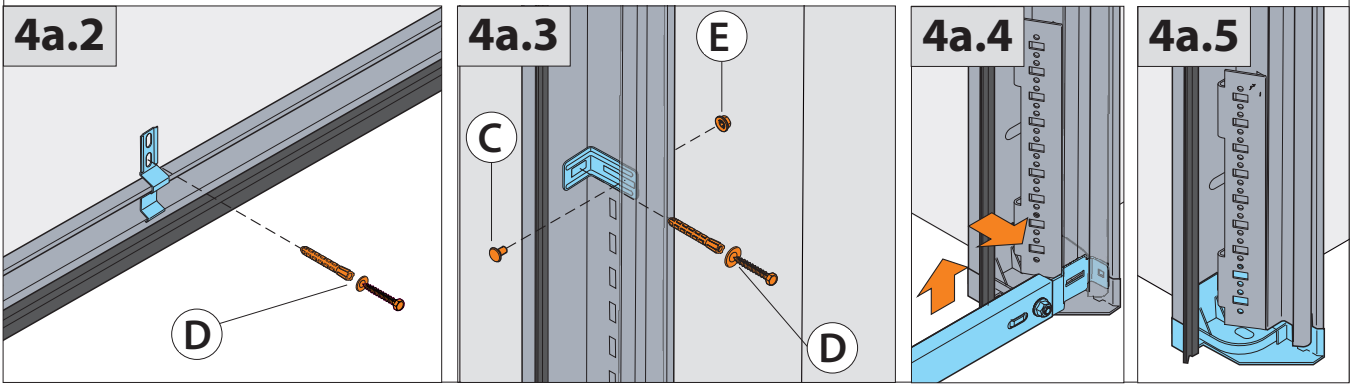

4b

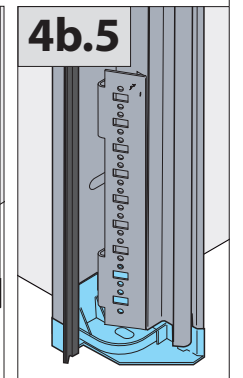
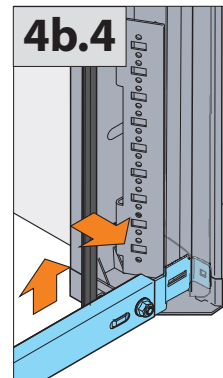
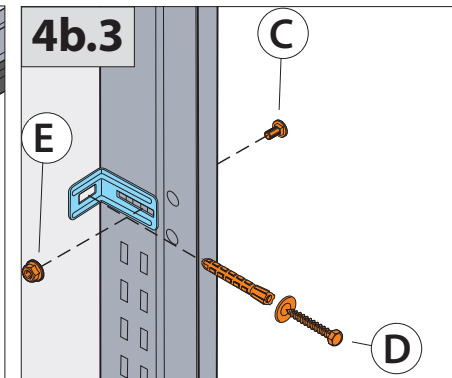
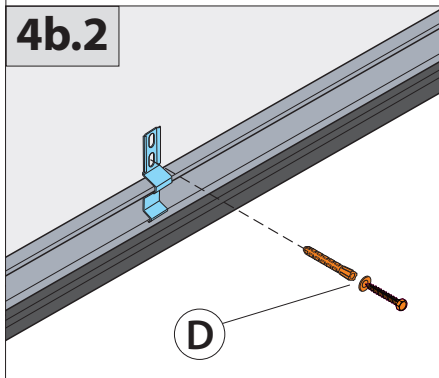
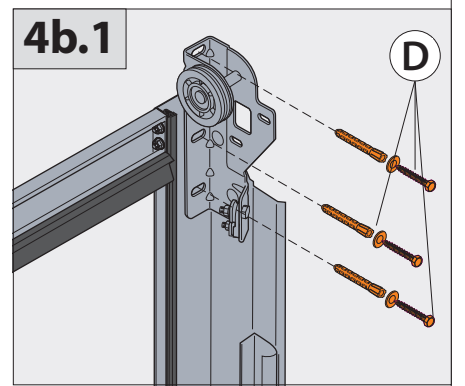
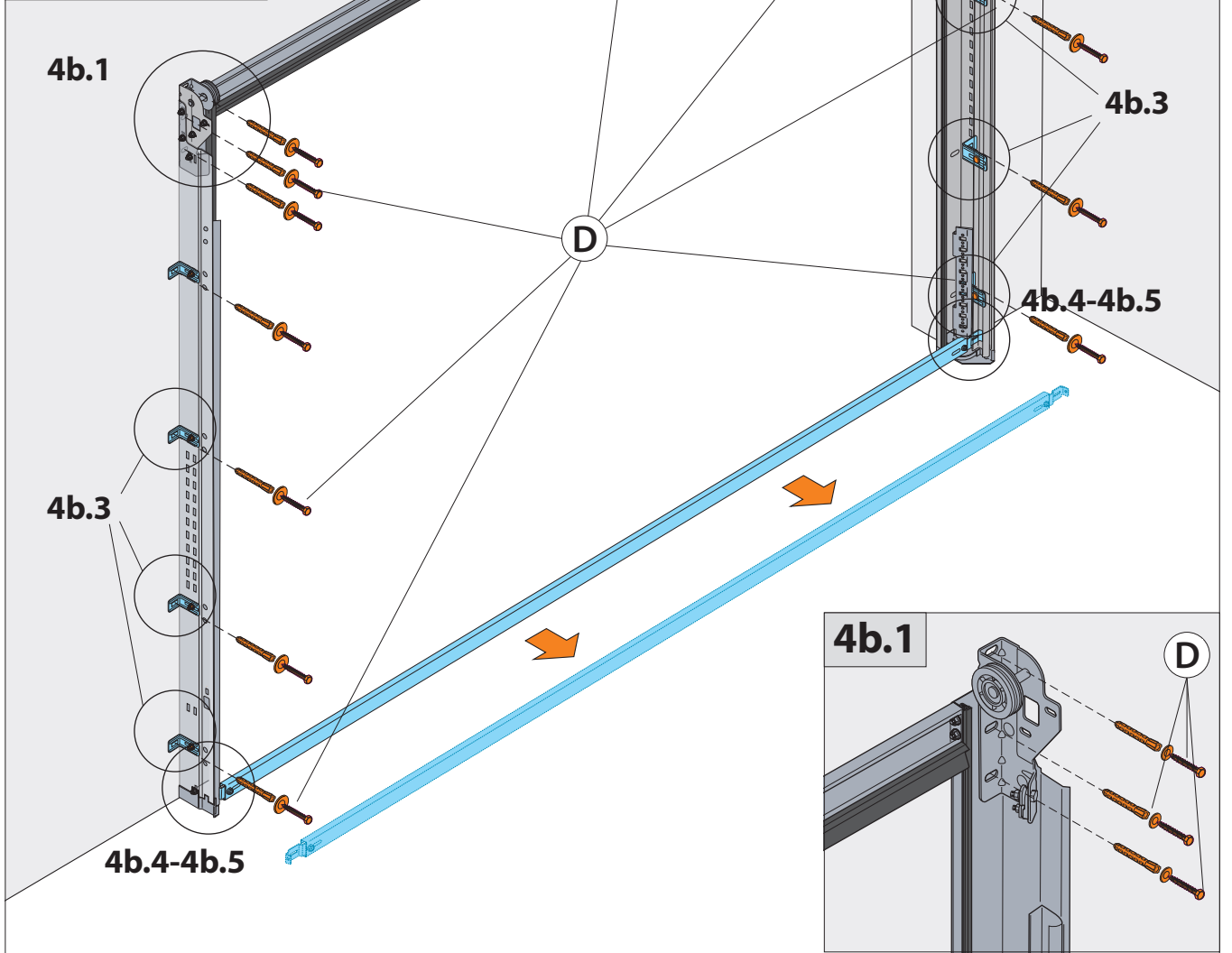
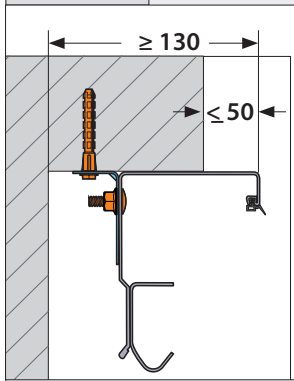

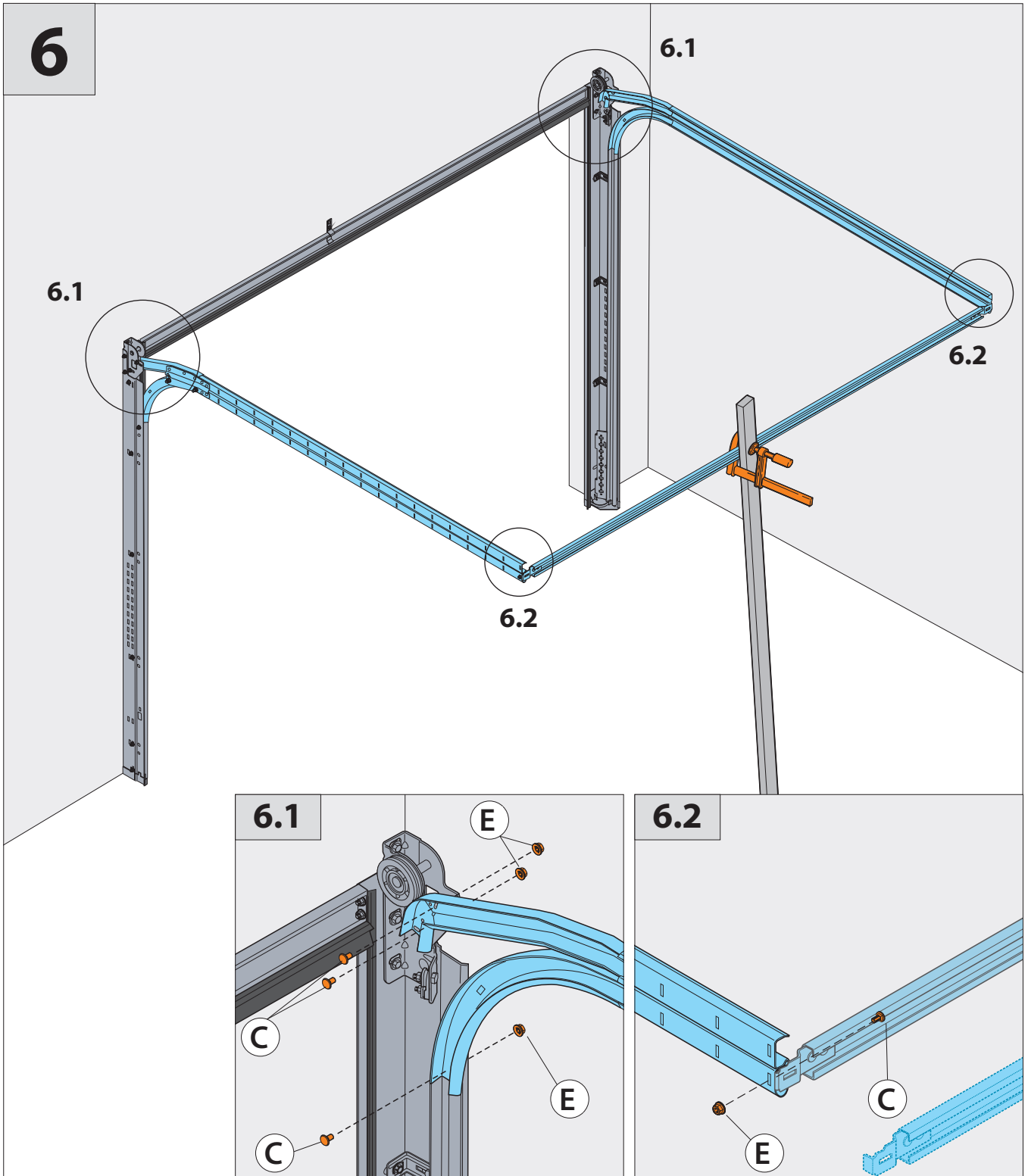
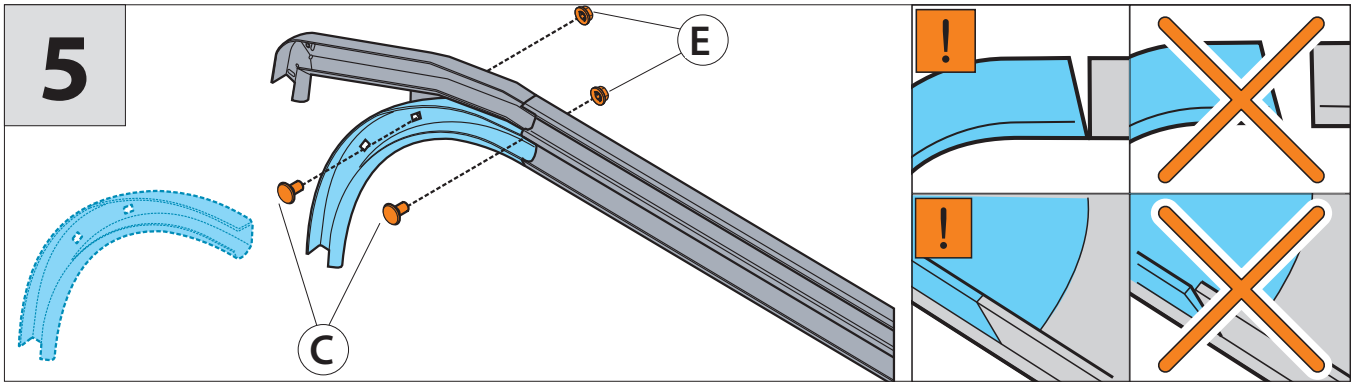

7a

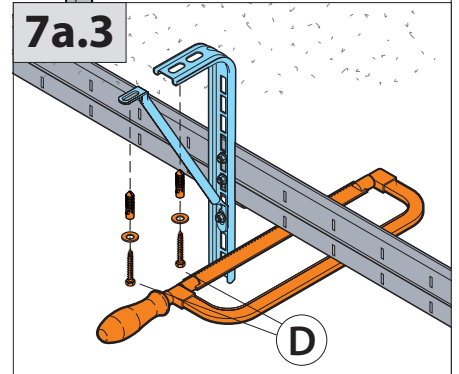
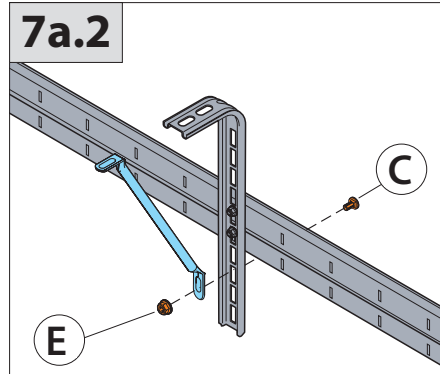
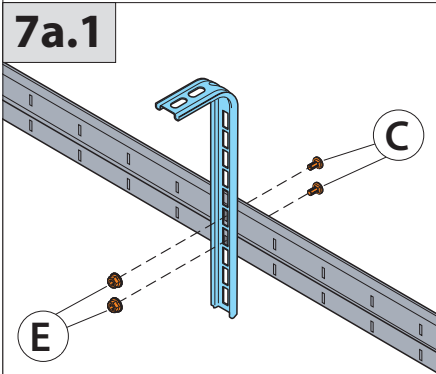
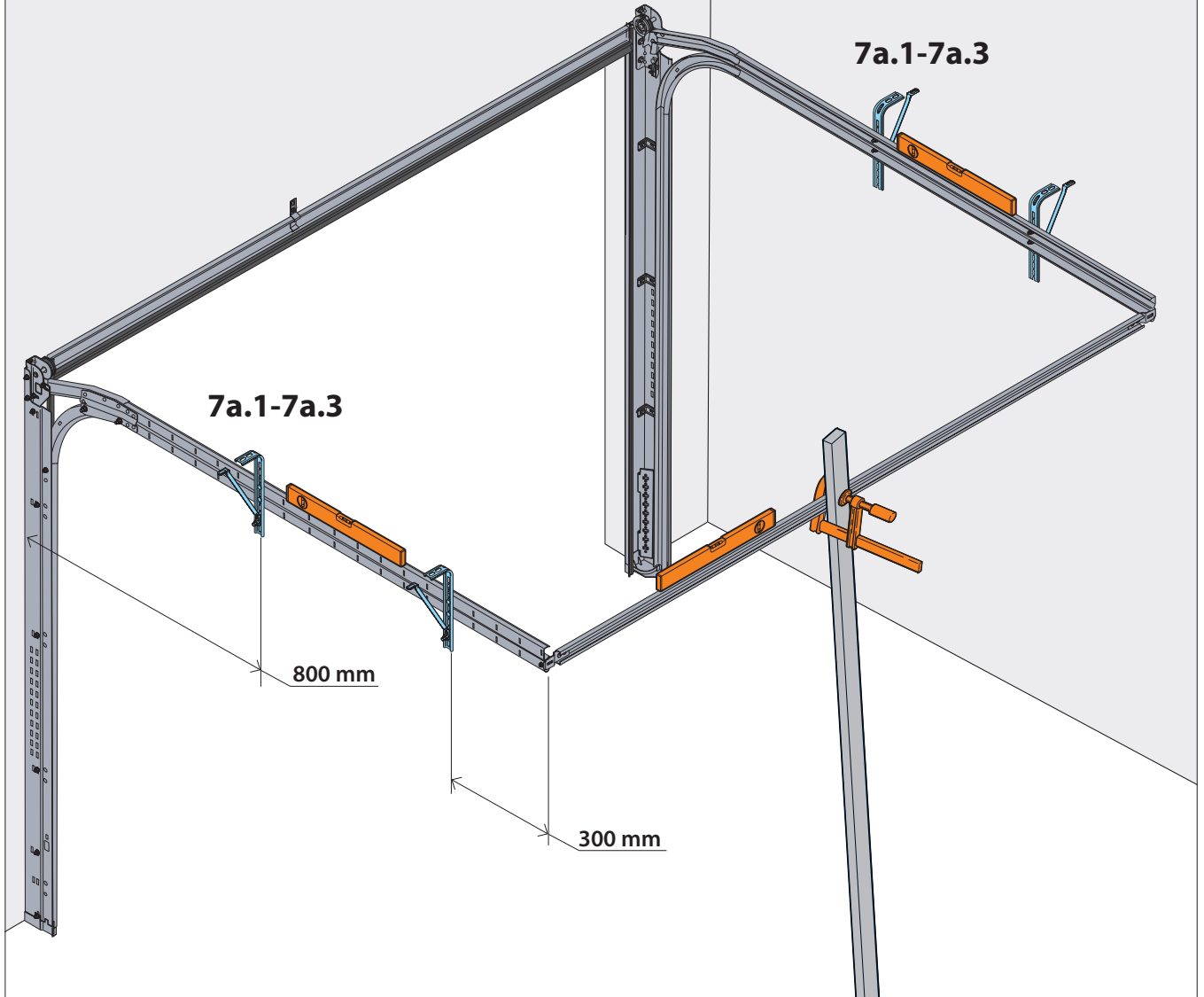
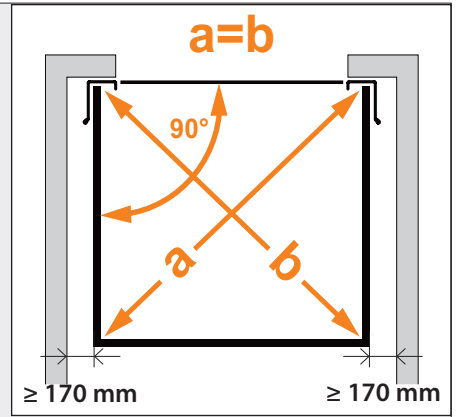

7b

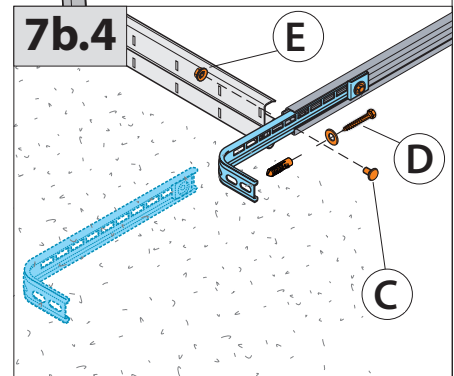
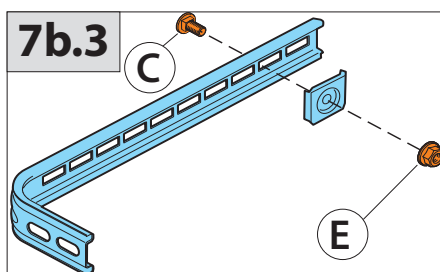
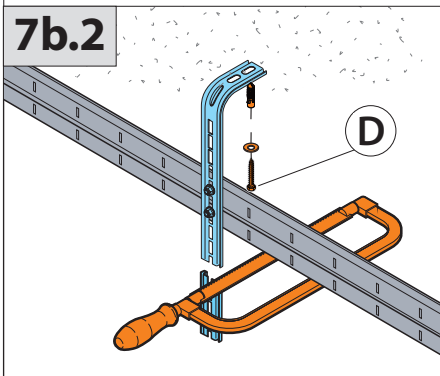
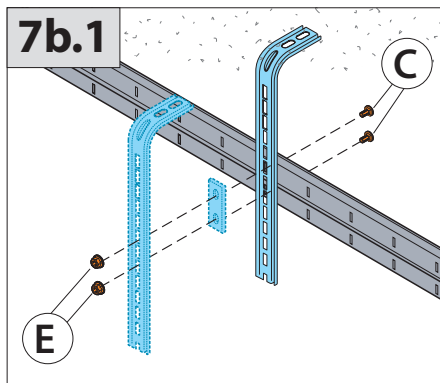
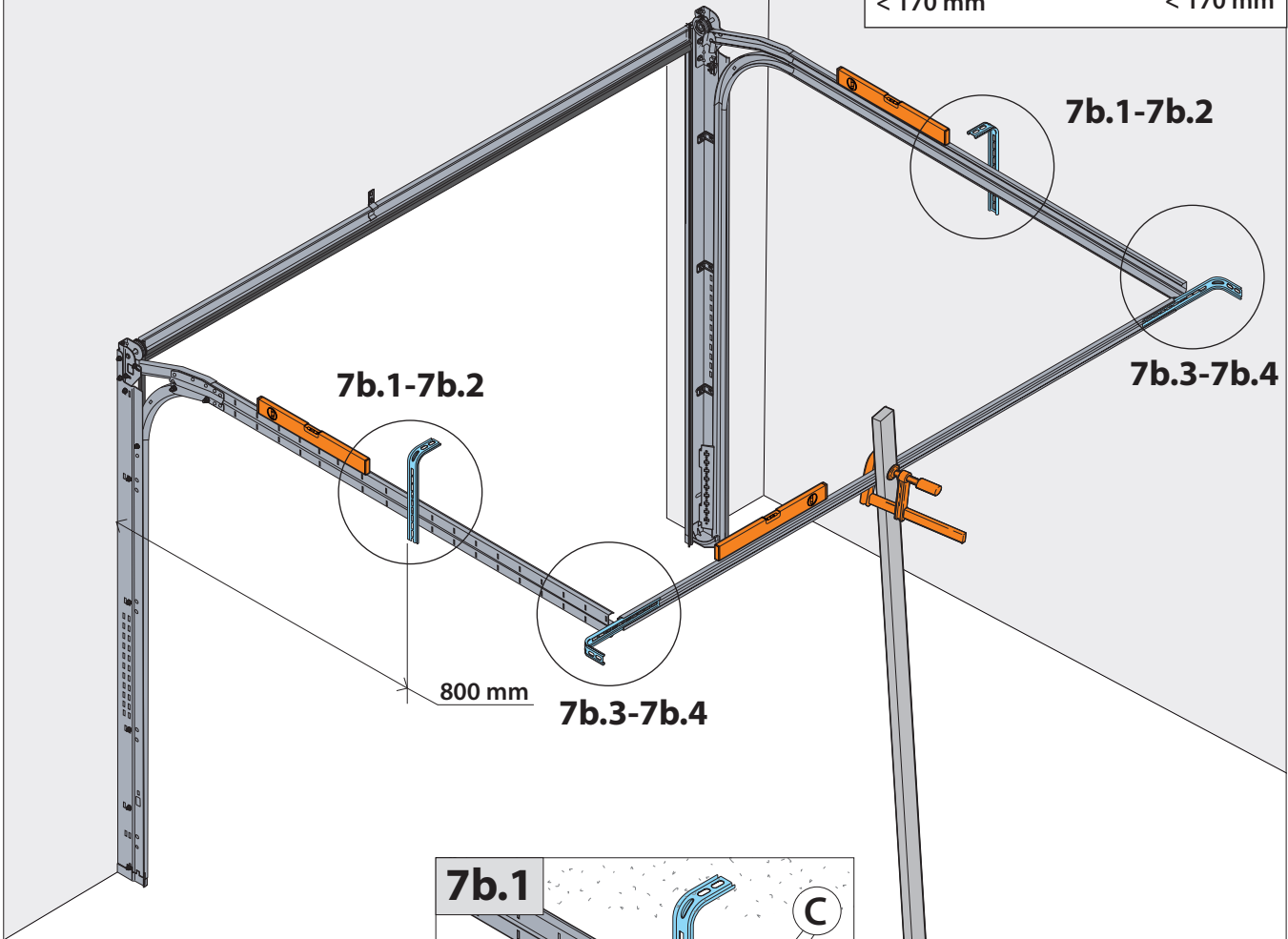
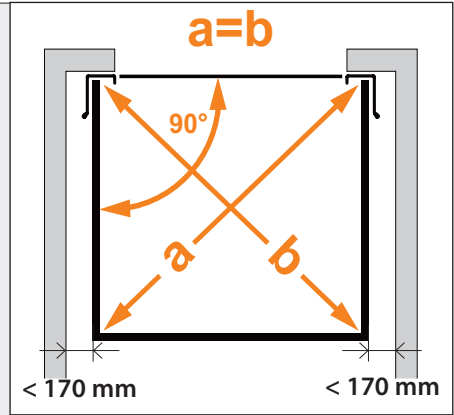

8

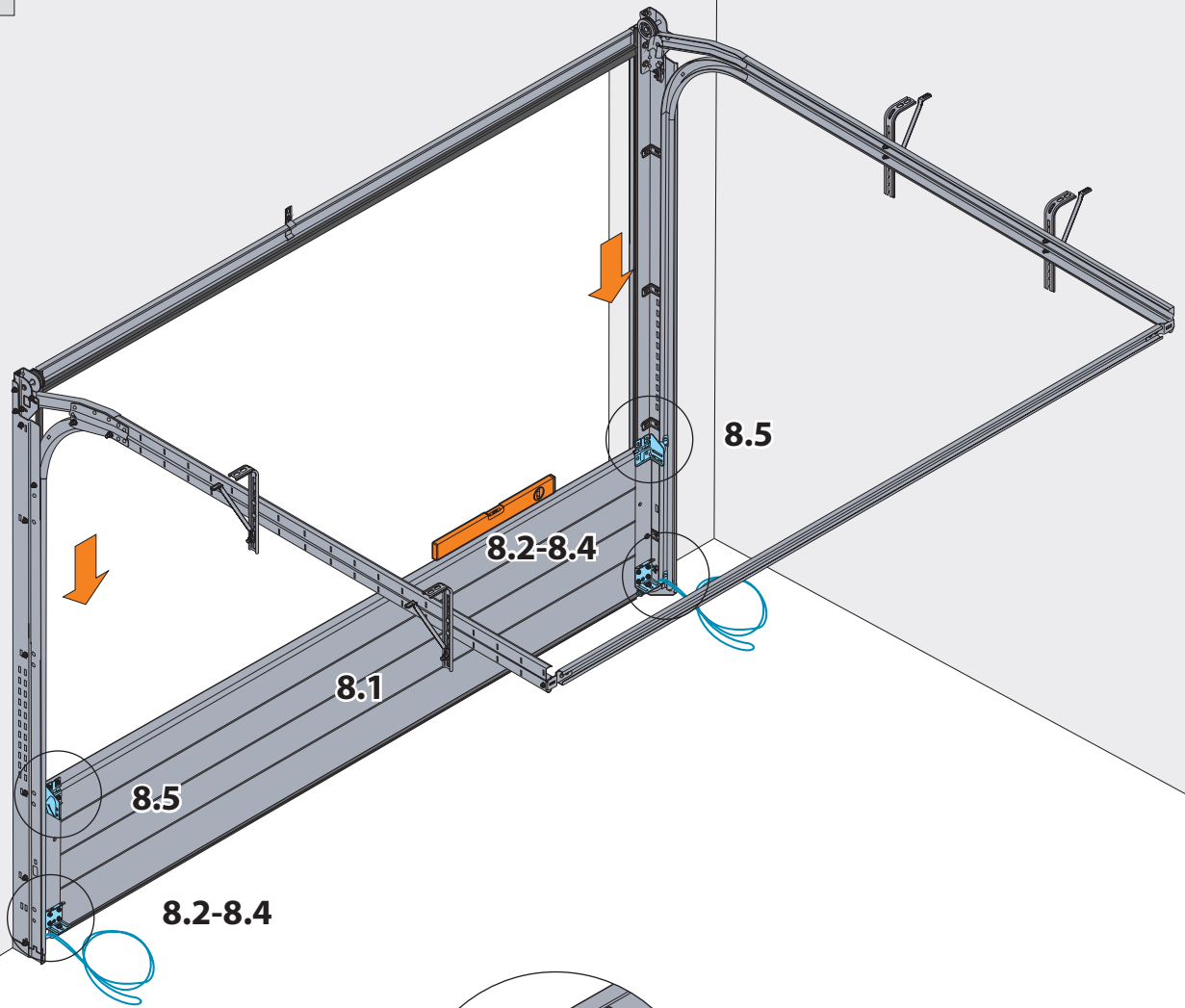

8.1

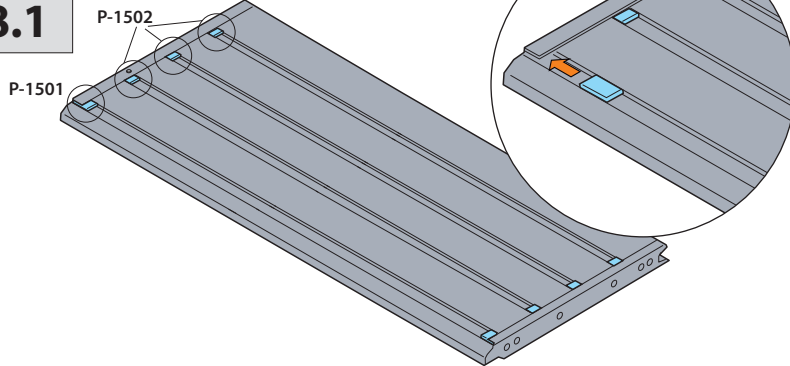

8.2

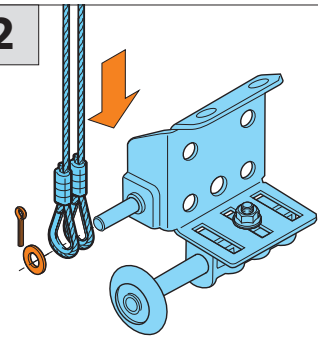

8.3

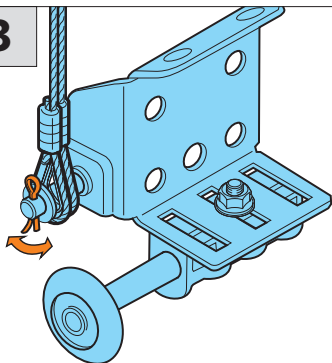

8.4

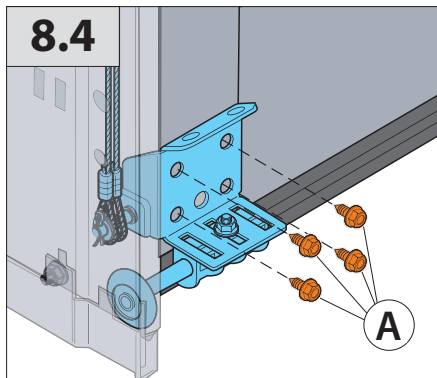

8.5

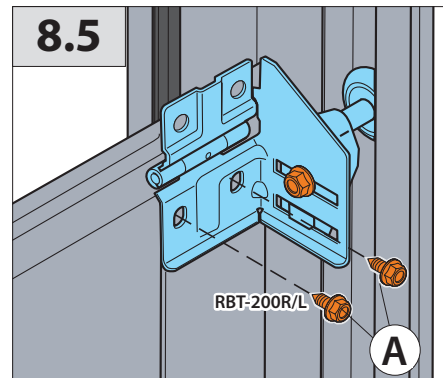

9

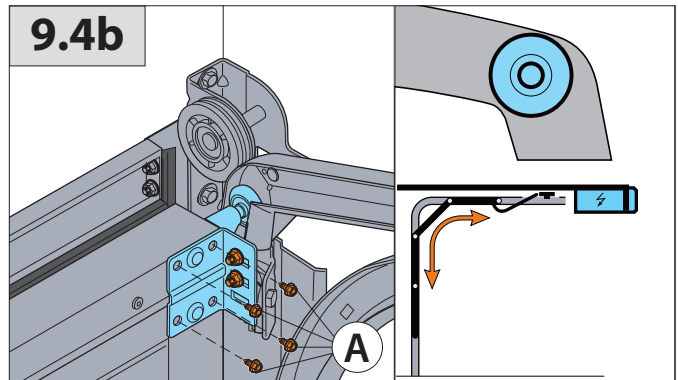
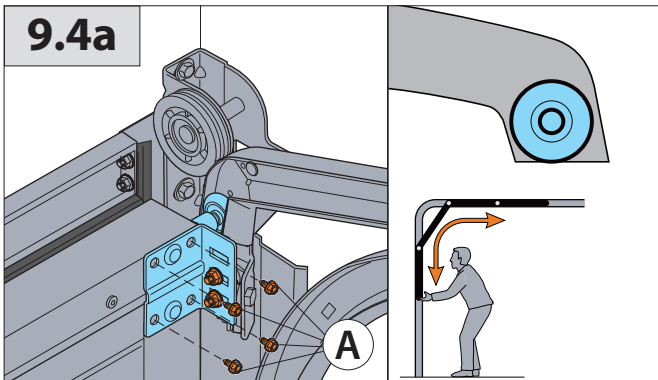
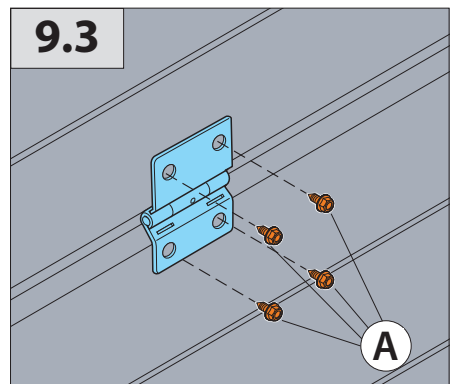
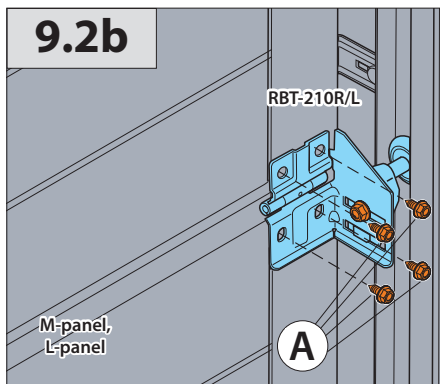
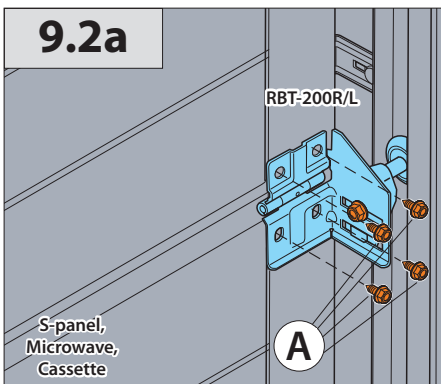
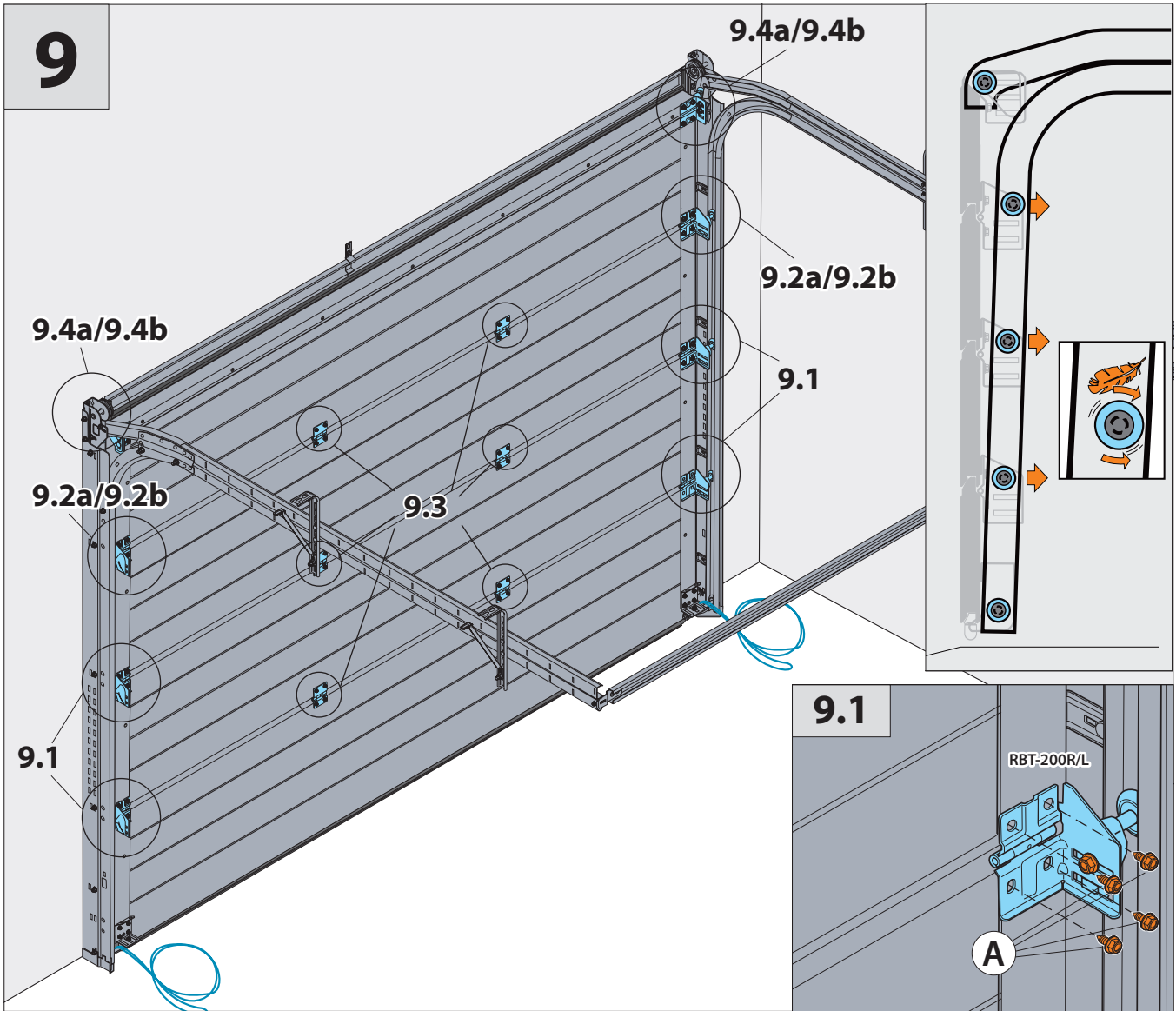

10

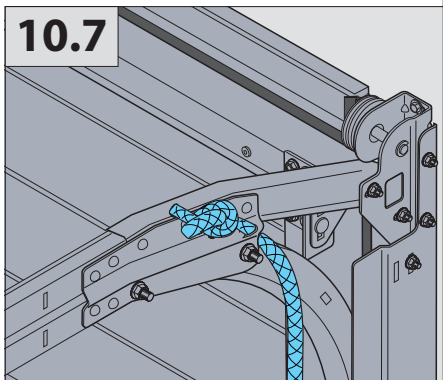
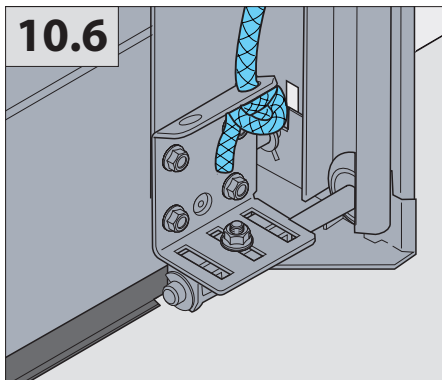
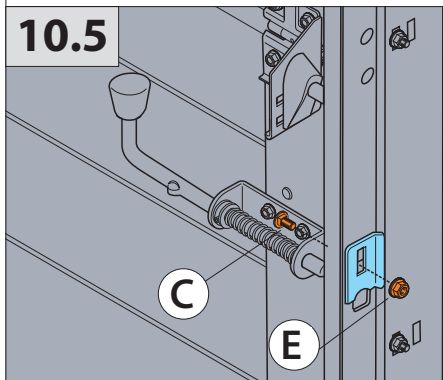
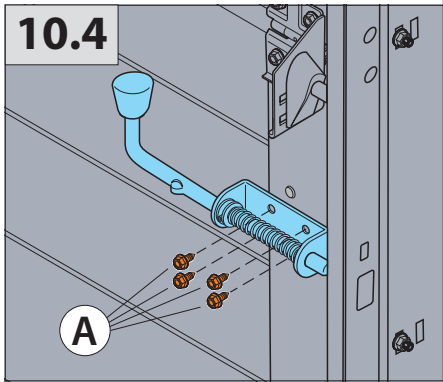
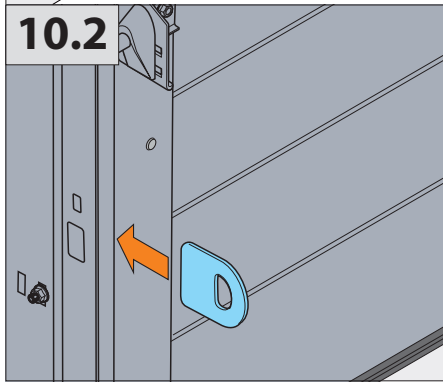
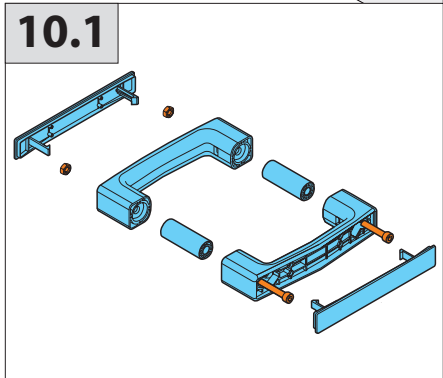
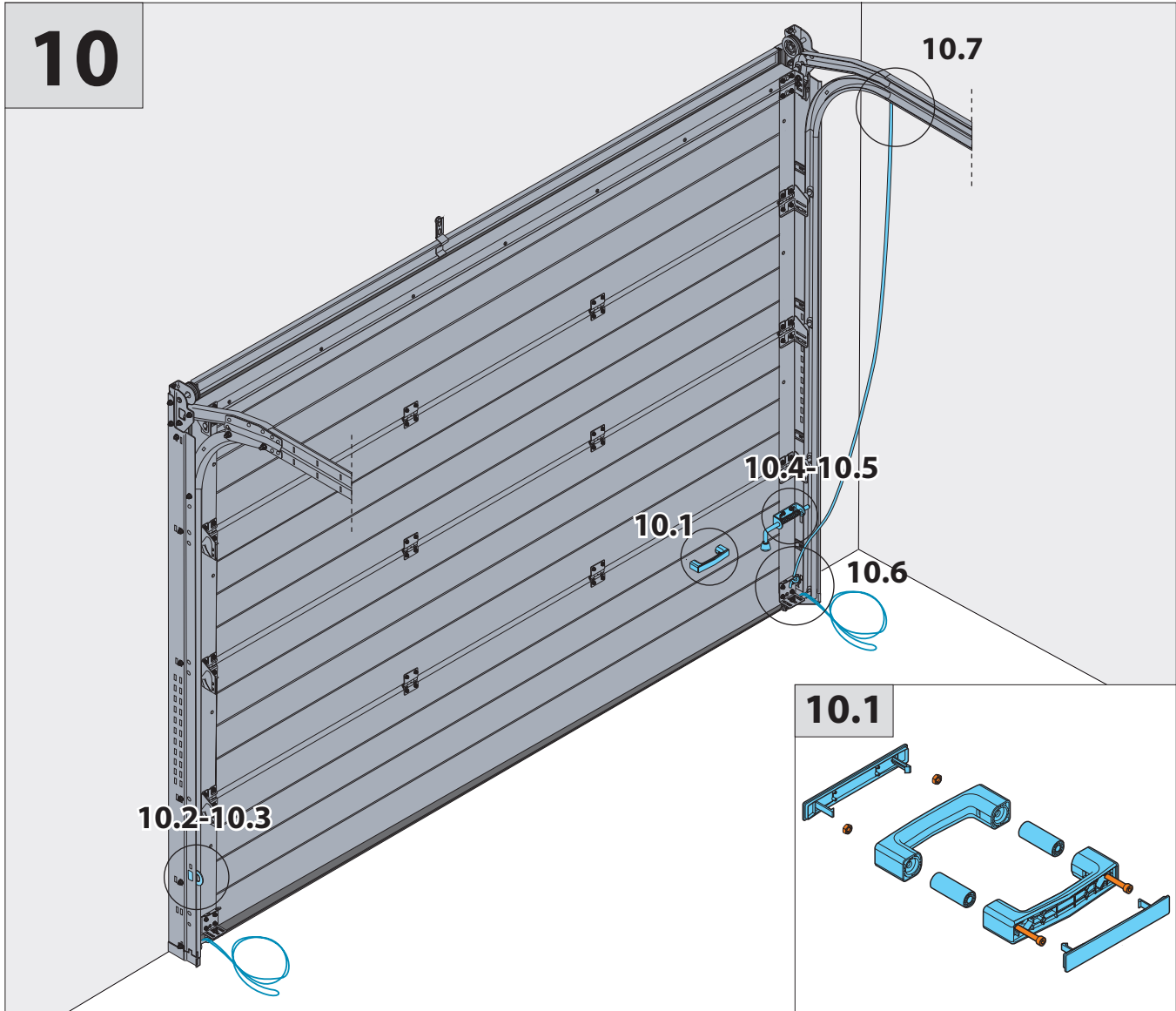

11

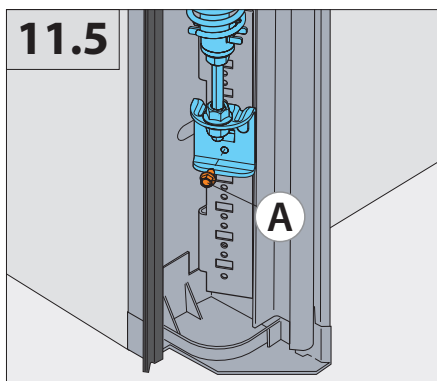
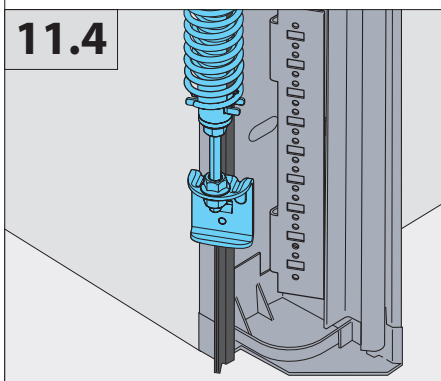
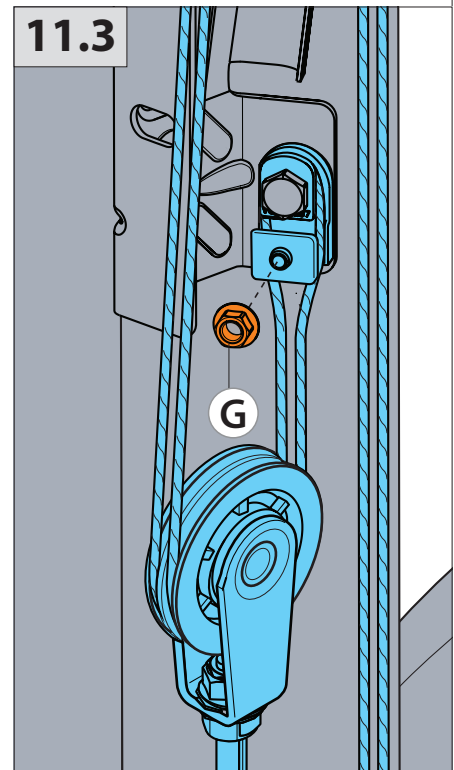
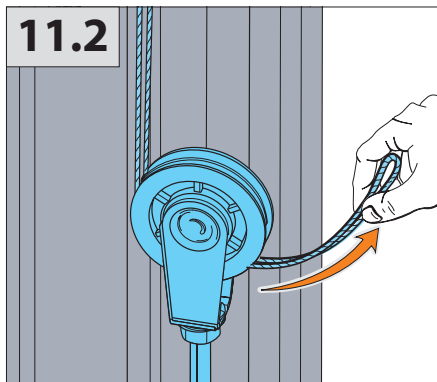
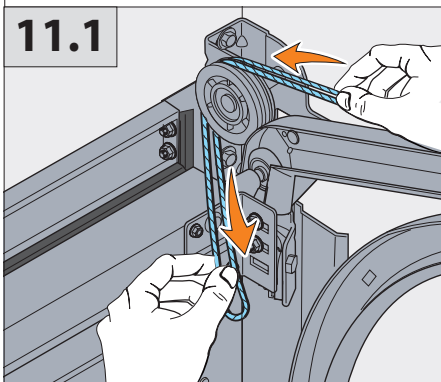
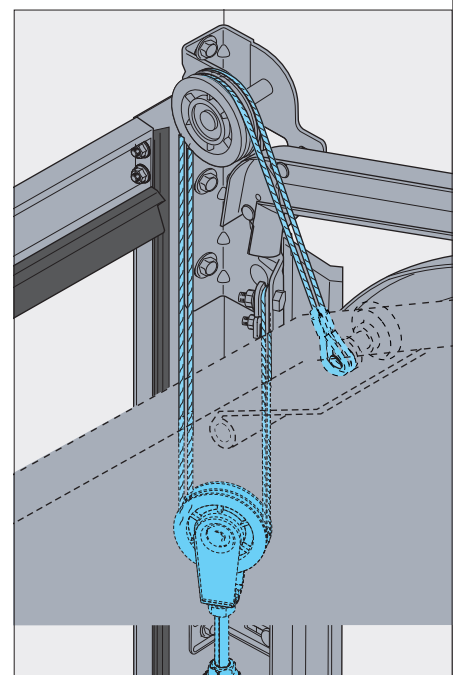
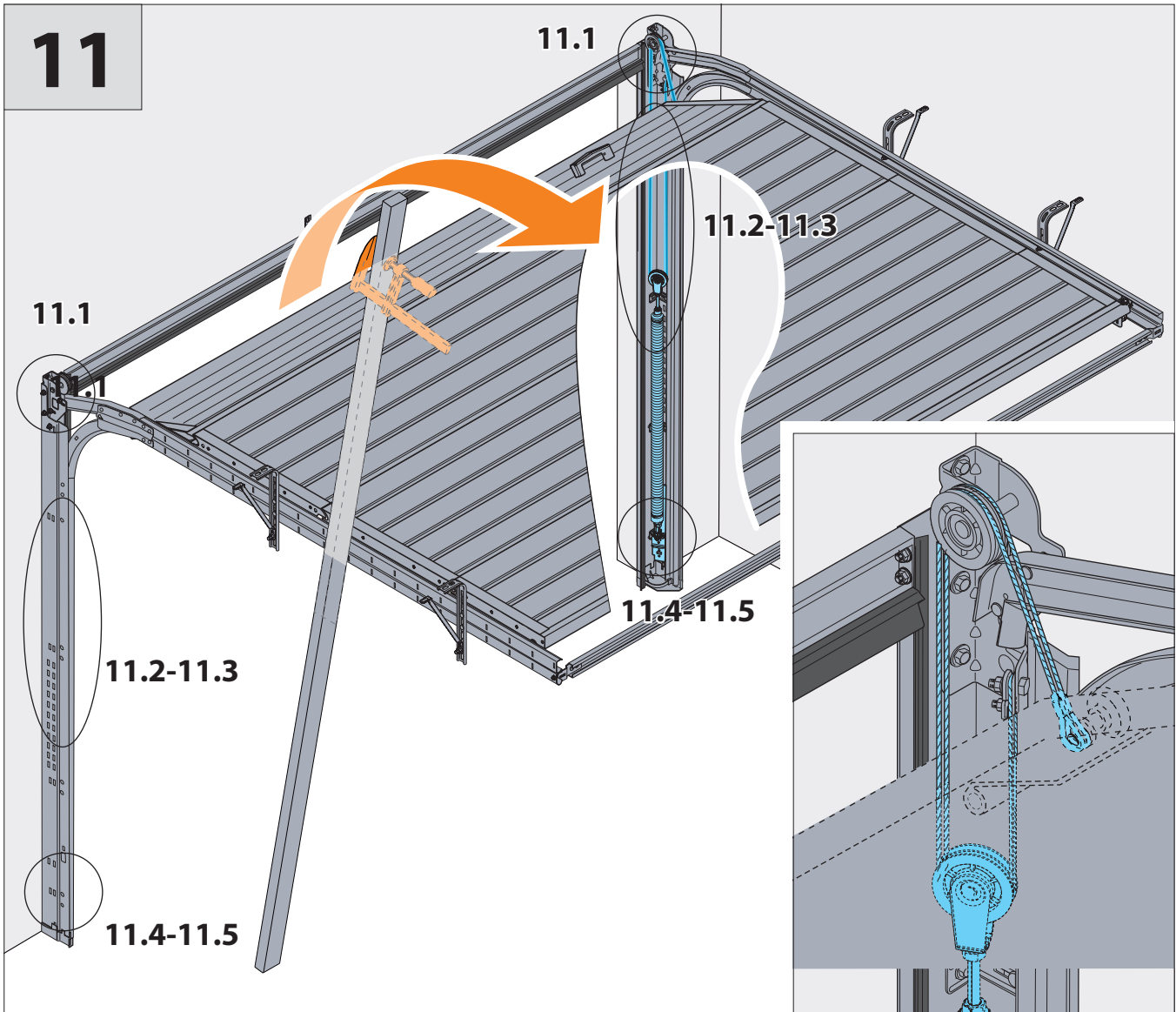

12

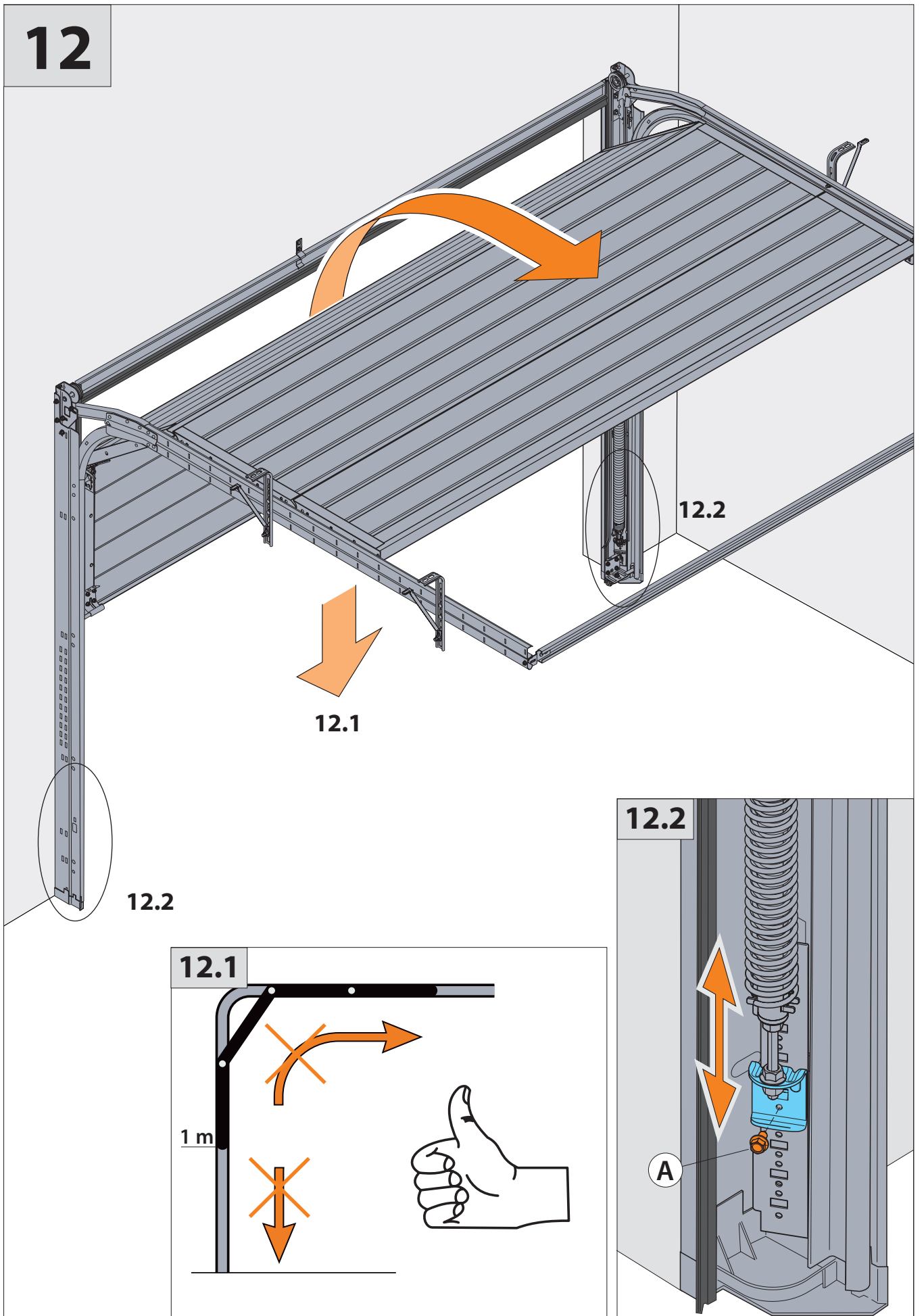

13a

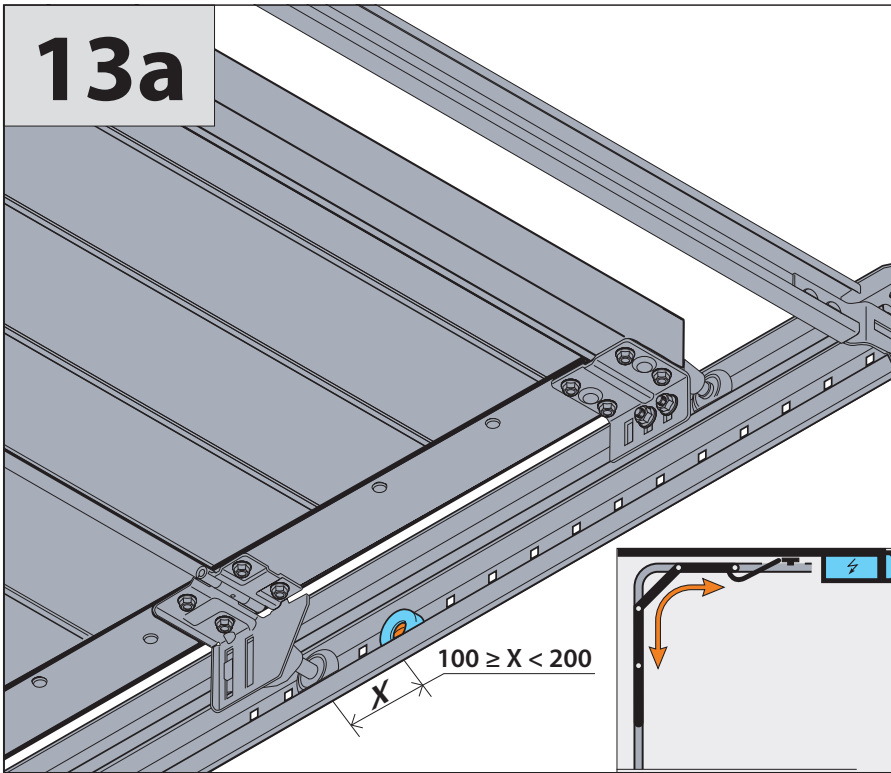

13a.1

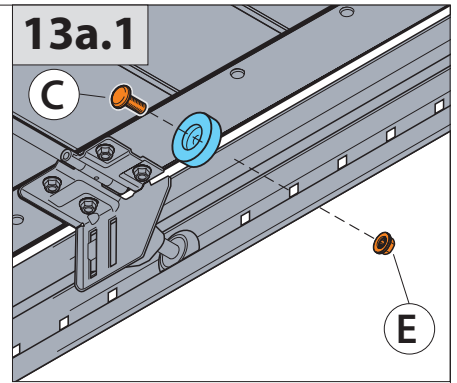

13b

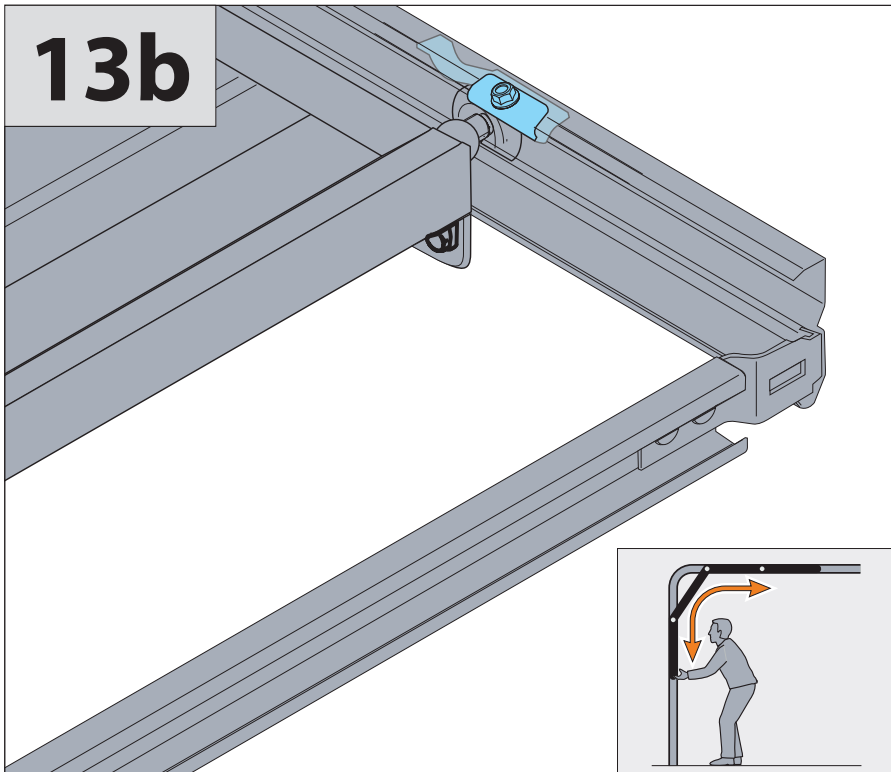

13b.1

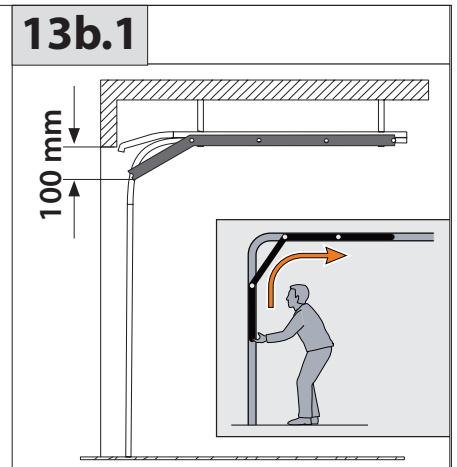

13b.2

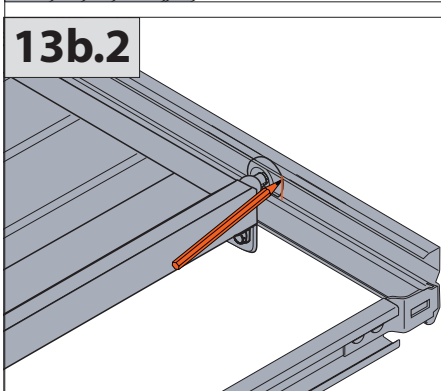

13b.3

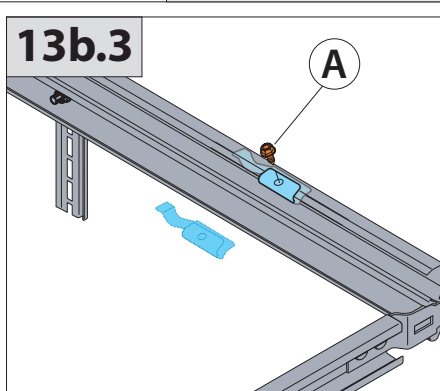

13b.4

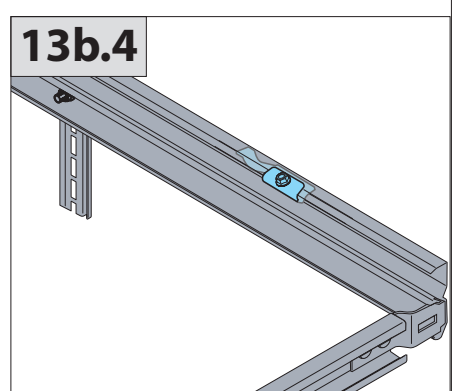

14

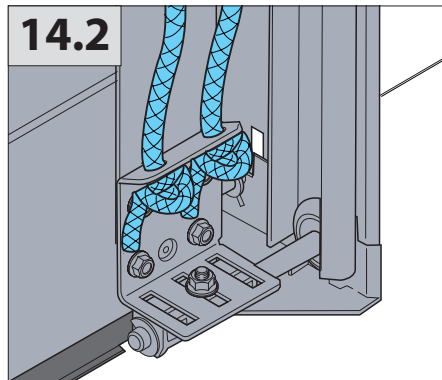
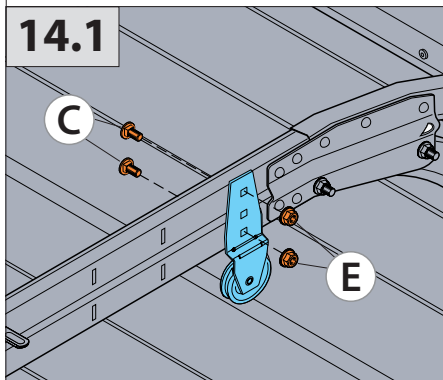
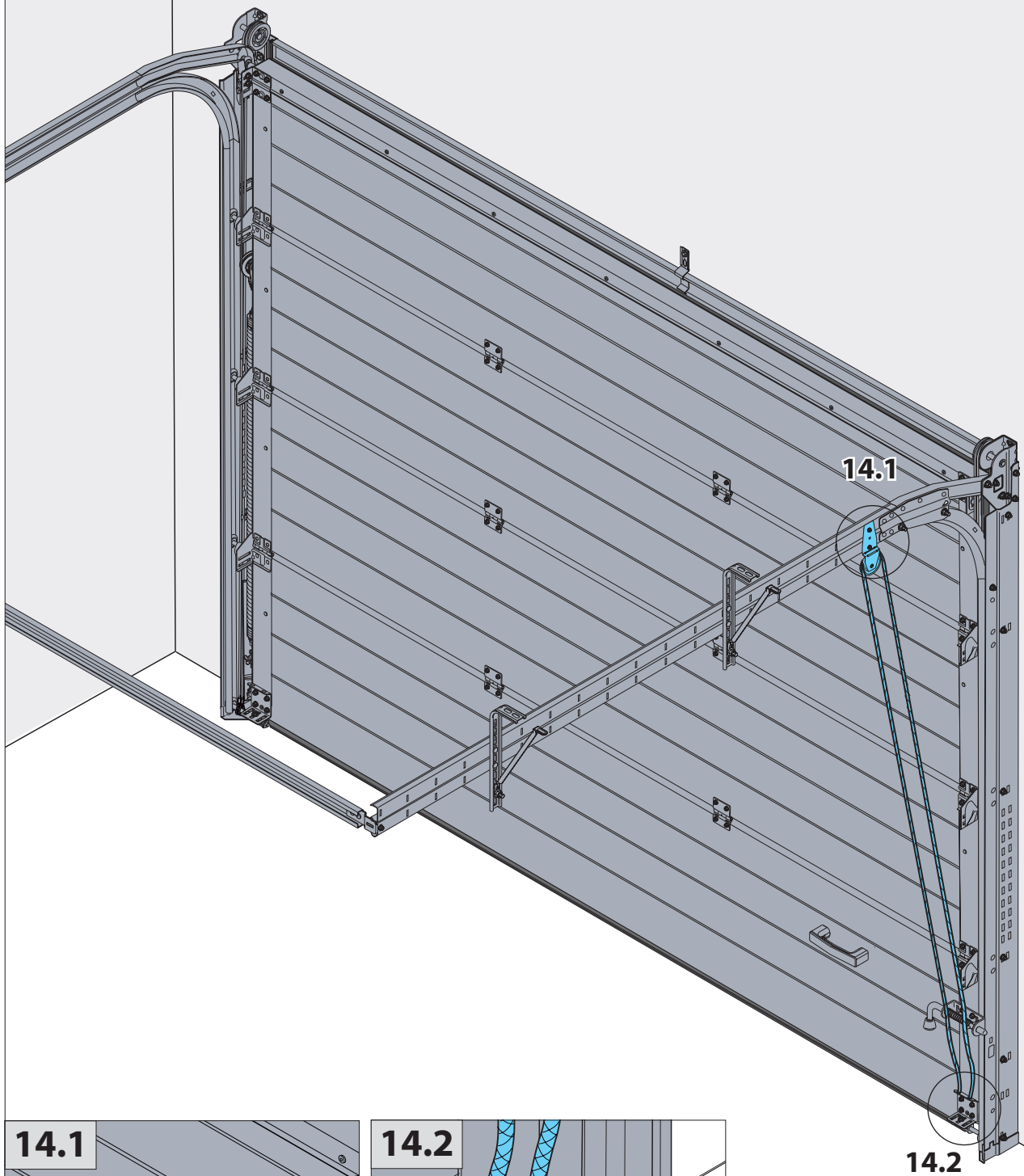

15

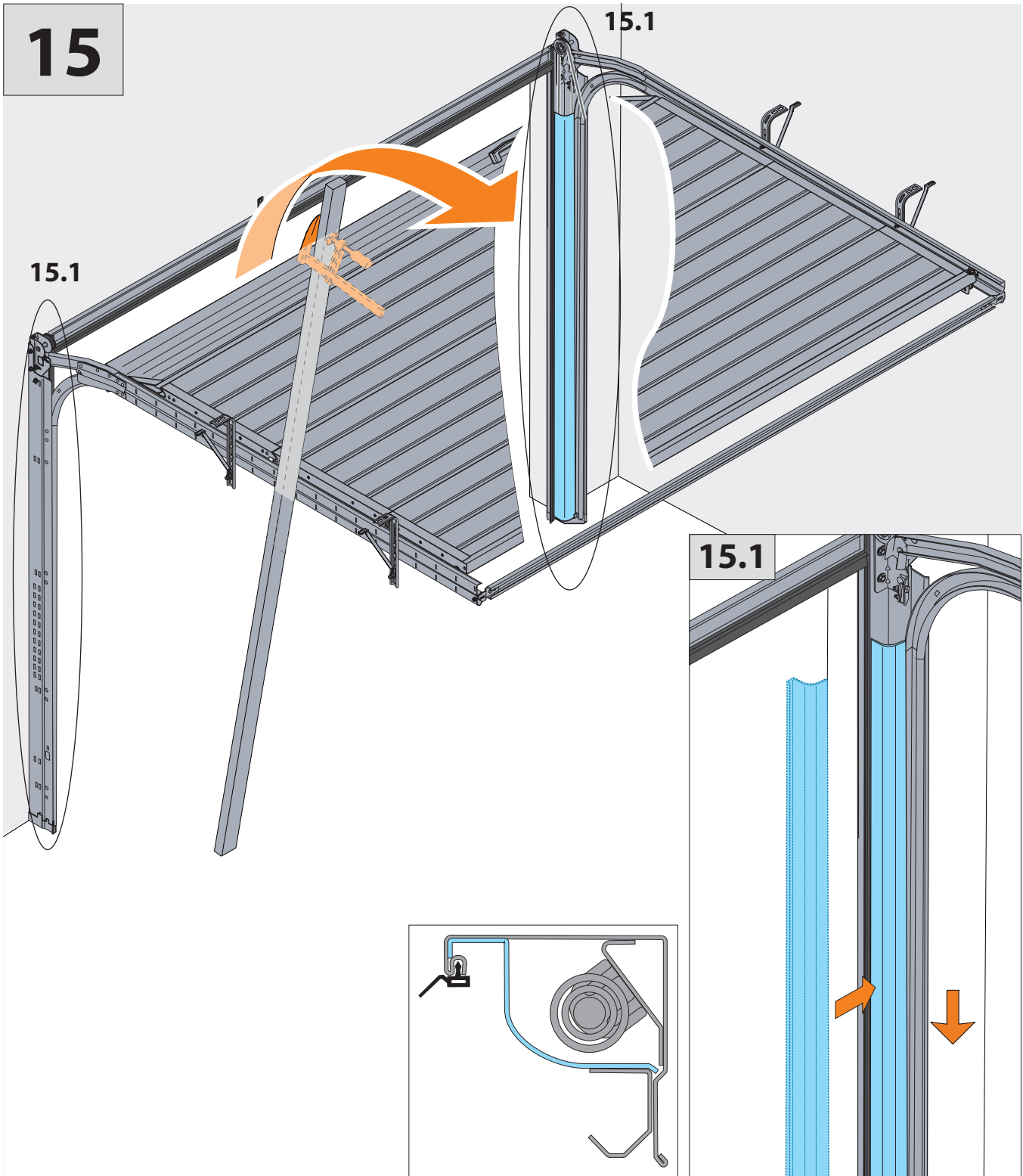

16

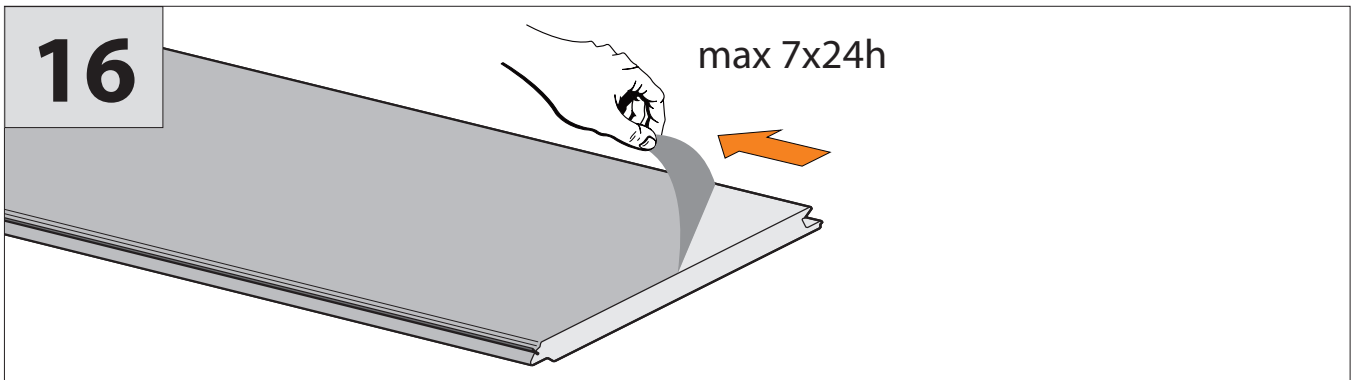

17

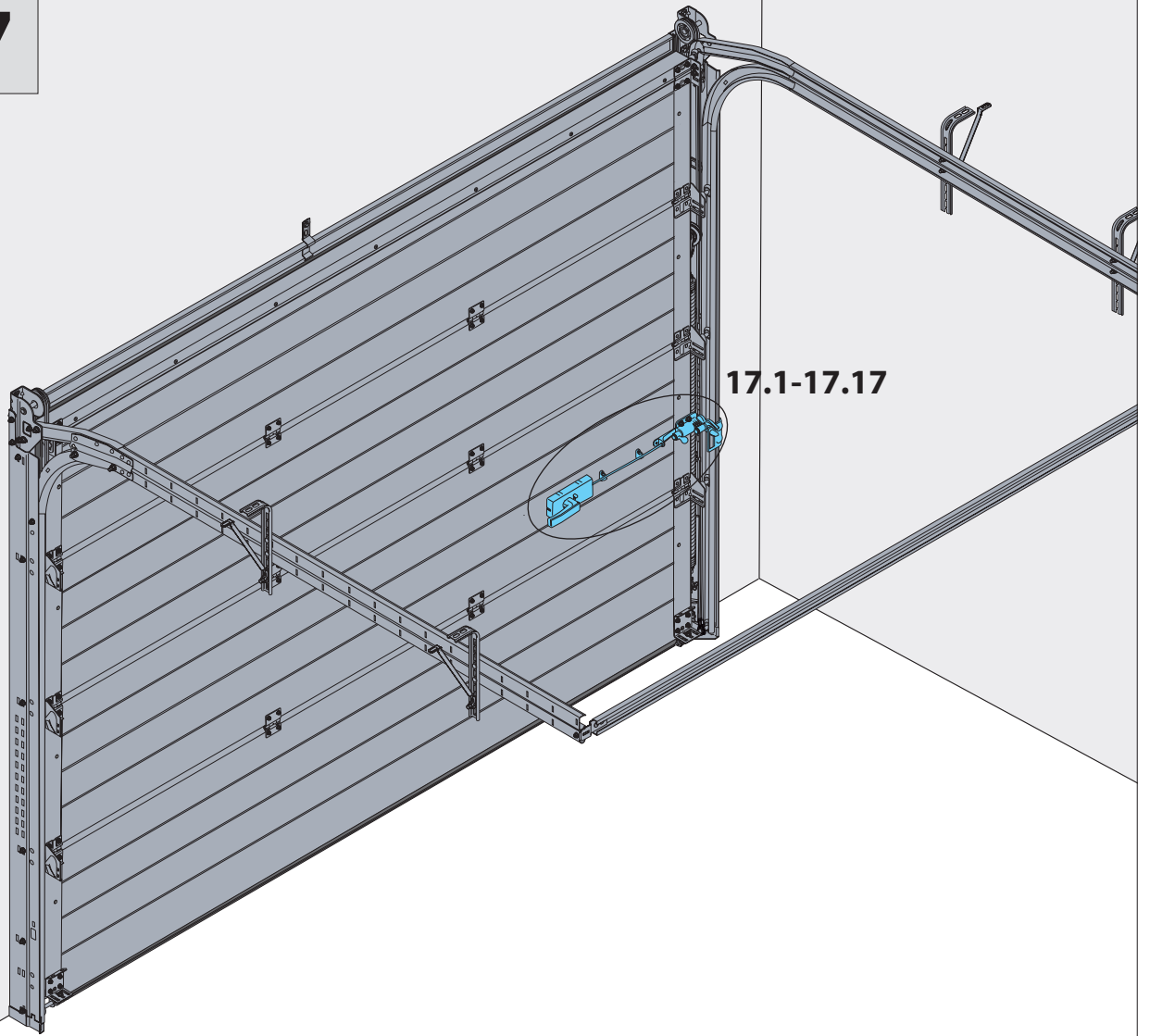

17.1

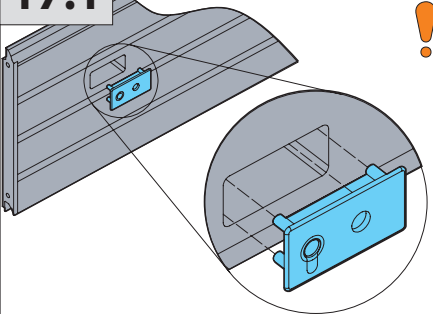

17.2

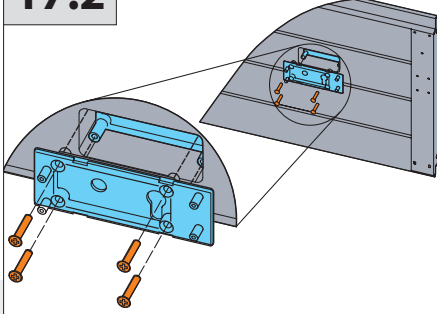

17.3

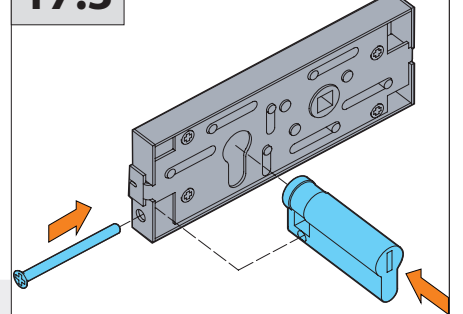

17.4

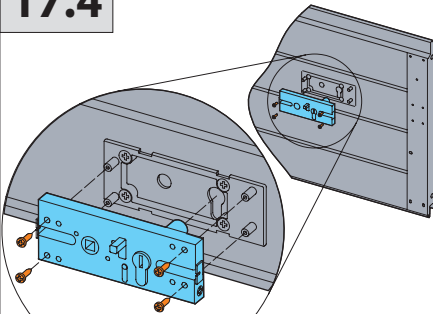

17.5

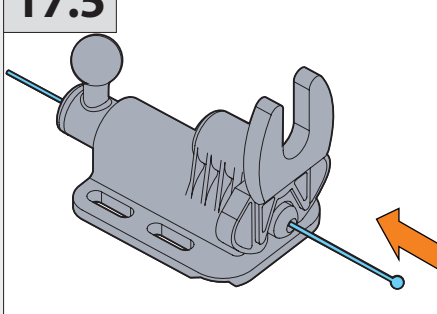

17.6

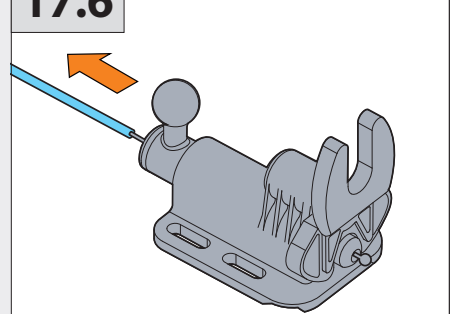

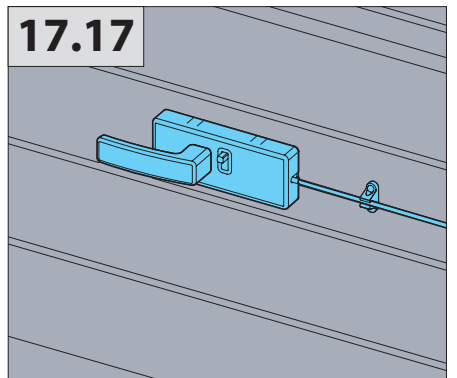
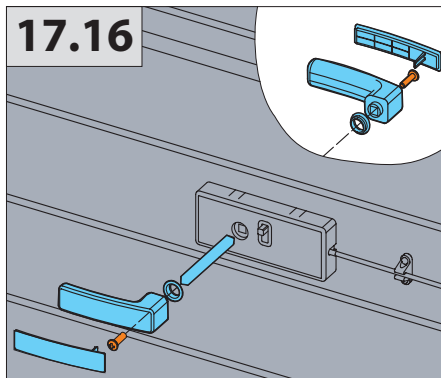
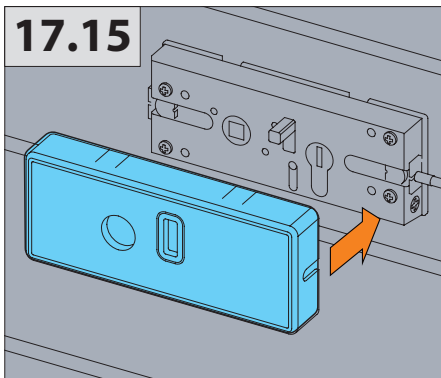
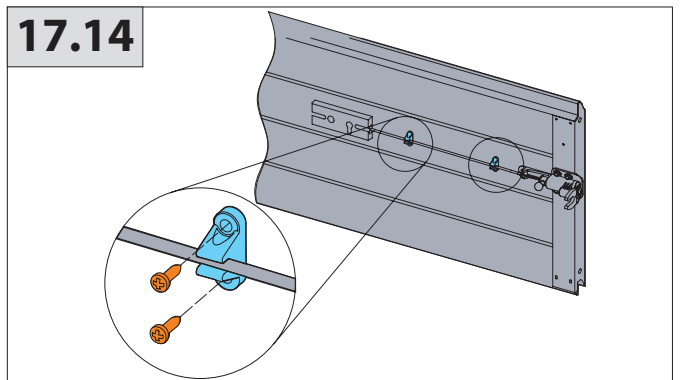
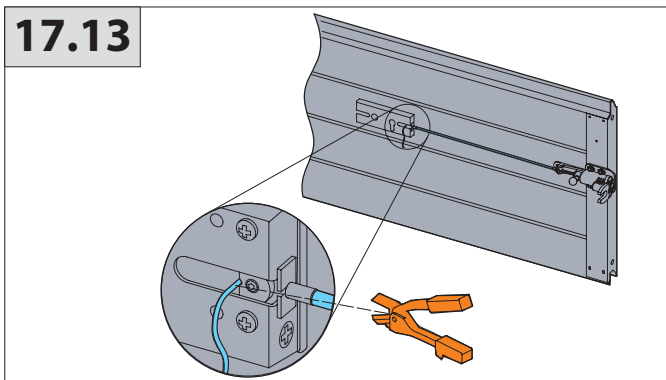
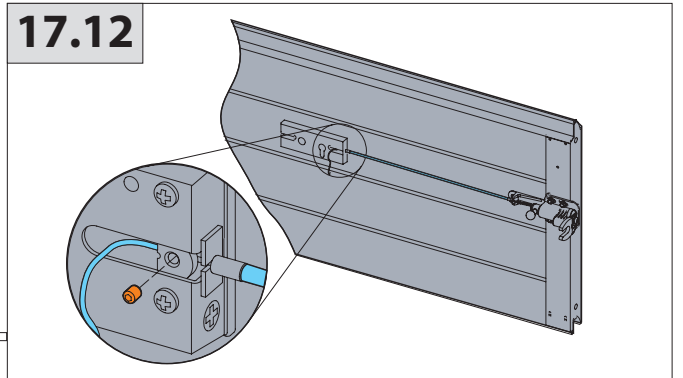
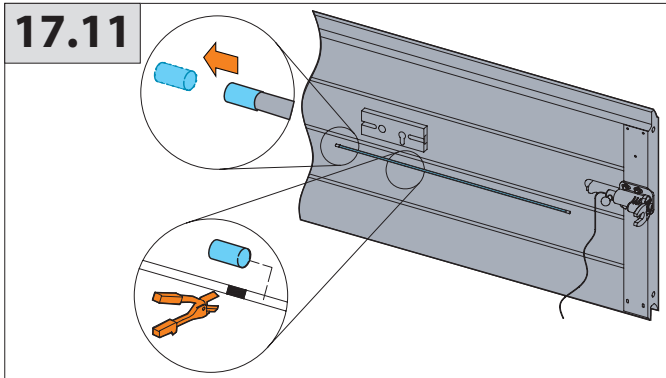
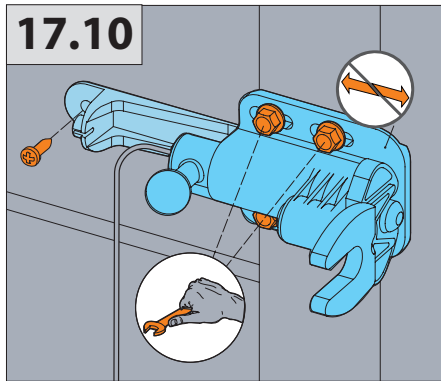
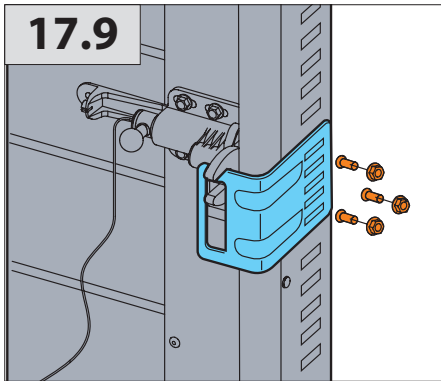
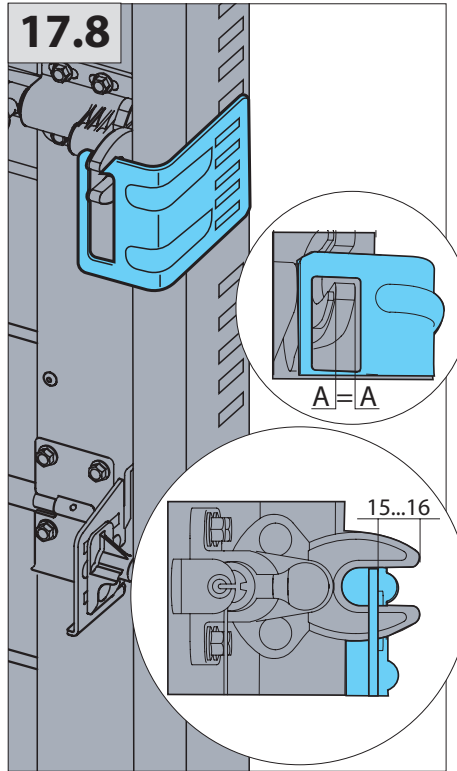
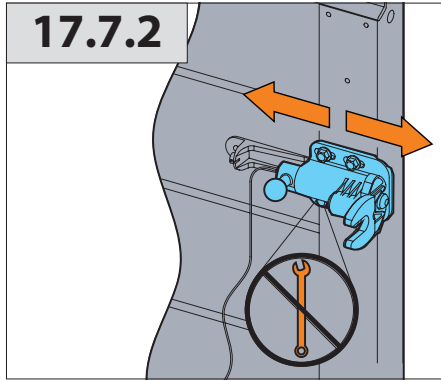
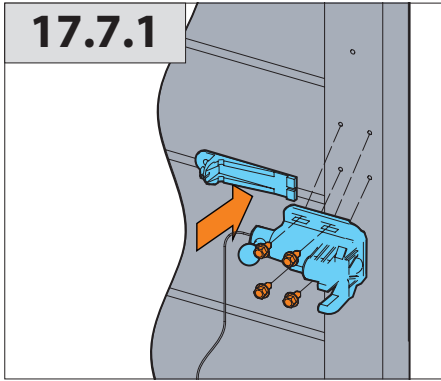

18

18.1-18.2

18.3-18.8

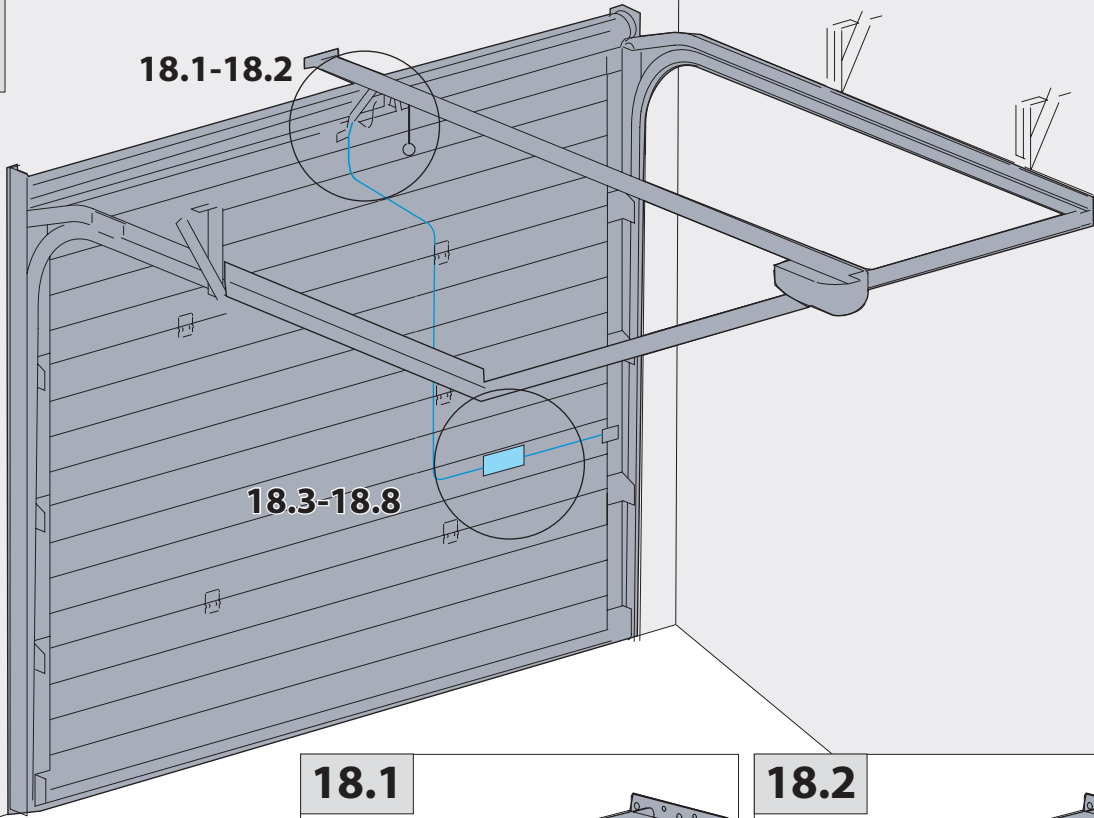

18.1

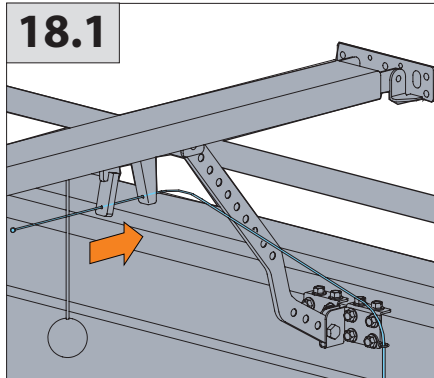

18.2

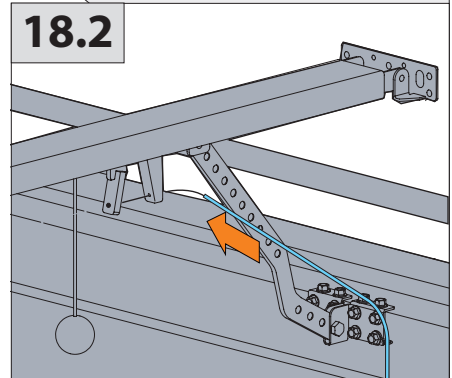

18.3

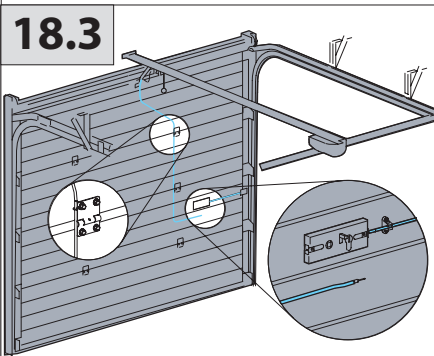

18.4.1

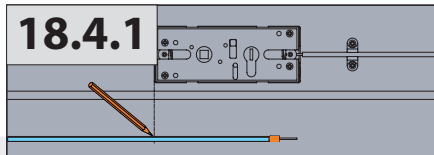

18.4.2

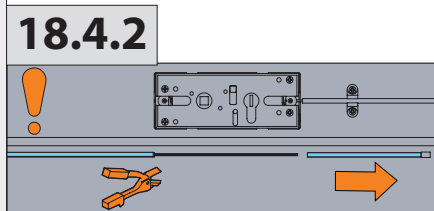

18.5.1

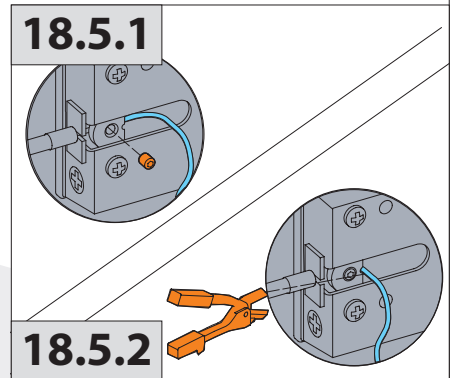

18.5.2

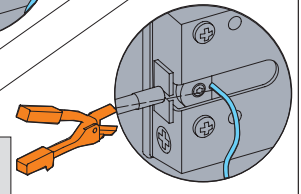

18.6

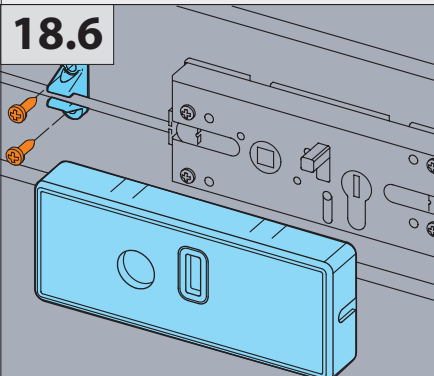

18.7

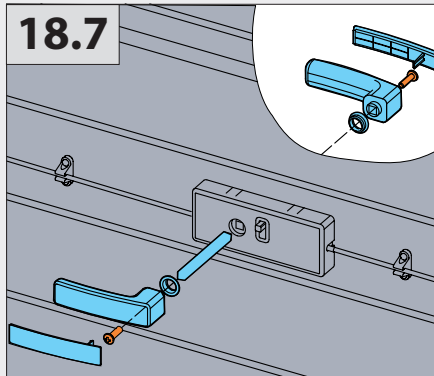

18.8

