

The retractable gear allows the door to be retracted inside the garage when opened by means of horizontal overhead tracks supported by wall or ceiling mounted suspension brackets. This gear is available as an option for single doors and comes as standard with double garage doors.

The nominal drive through clearance is 105mm less than the opening width and 110mm less than the opening height for single doors, and 140mm less than the opening height for double doors.

For doors fitted with an operator, please respect operator specifications.

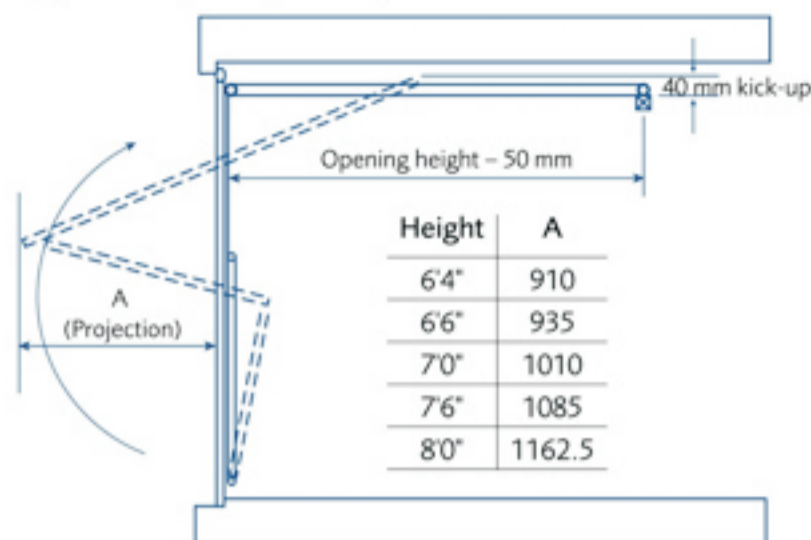

On Site Timber Frame

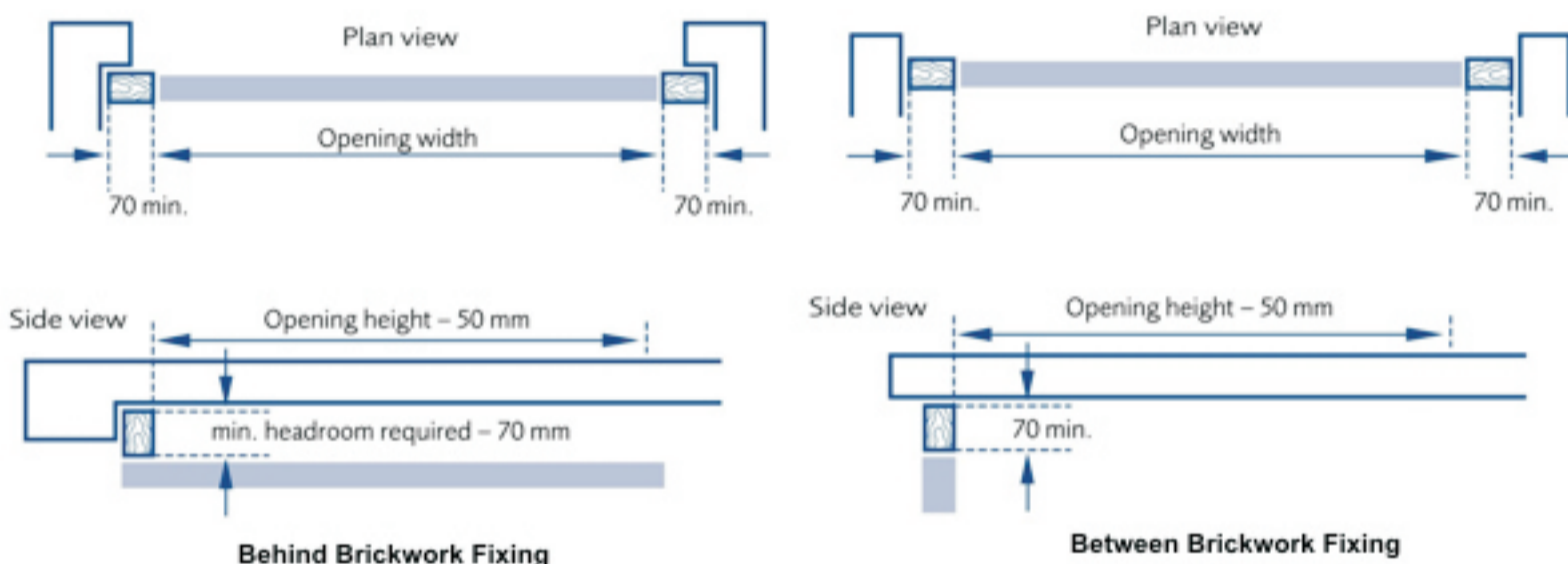

The garage door is supplied factory fitted to a steel box section frame and is secured to the brickwork using just 7 fixings.

Factory pre-framed with steel box frame

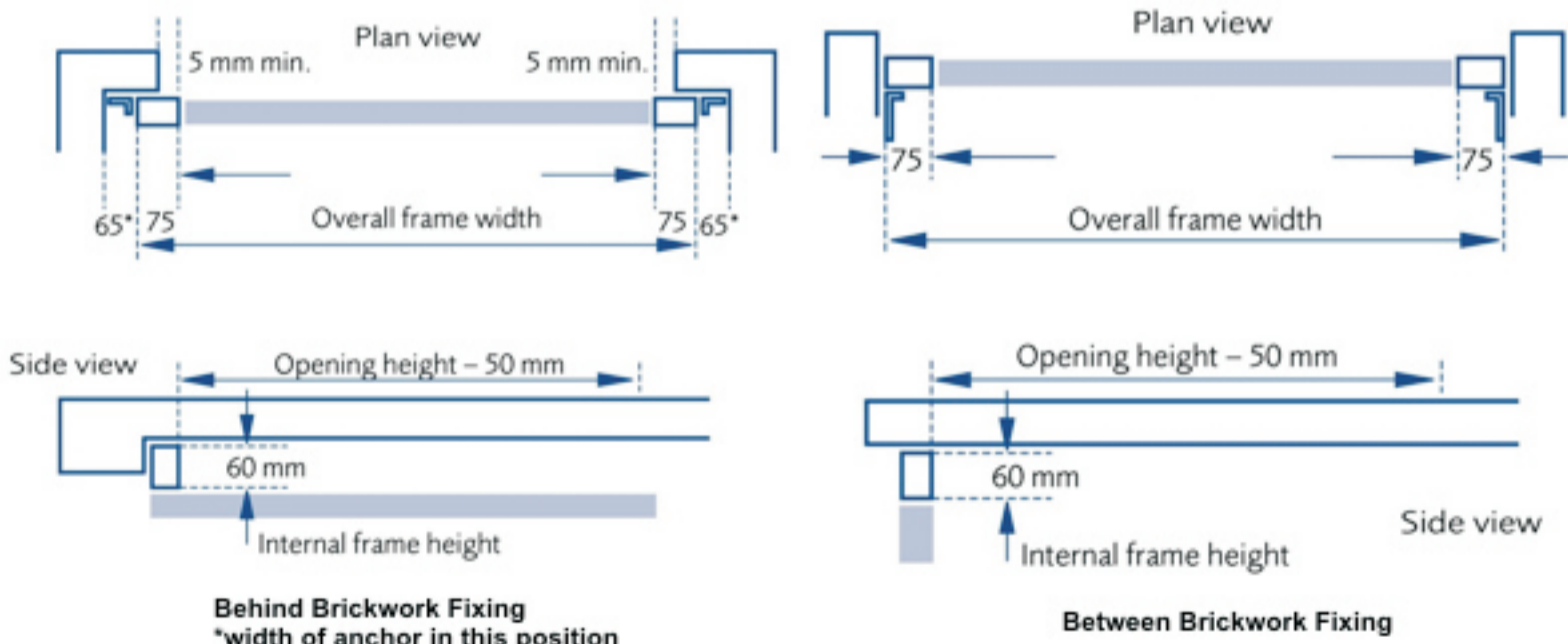

Retractable Plus Gear

For any door up to a width of 2744mm in any of the three standard heights, Retractable Plus gear is available. This gear type creates a clear drive through width at the crucial wing mirror height.

Door height	Clear height below lifting arms
7'0"	1260
6'6"	1105
6'4"	1055