



0800 525 442

www.thegaragedoorcente.co.uk

Installation Guide

Samson P16

Tools Required

Below is a list of tools that you will require to install the Samson P16 Canopy or Carport.

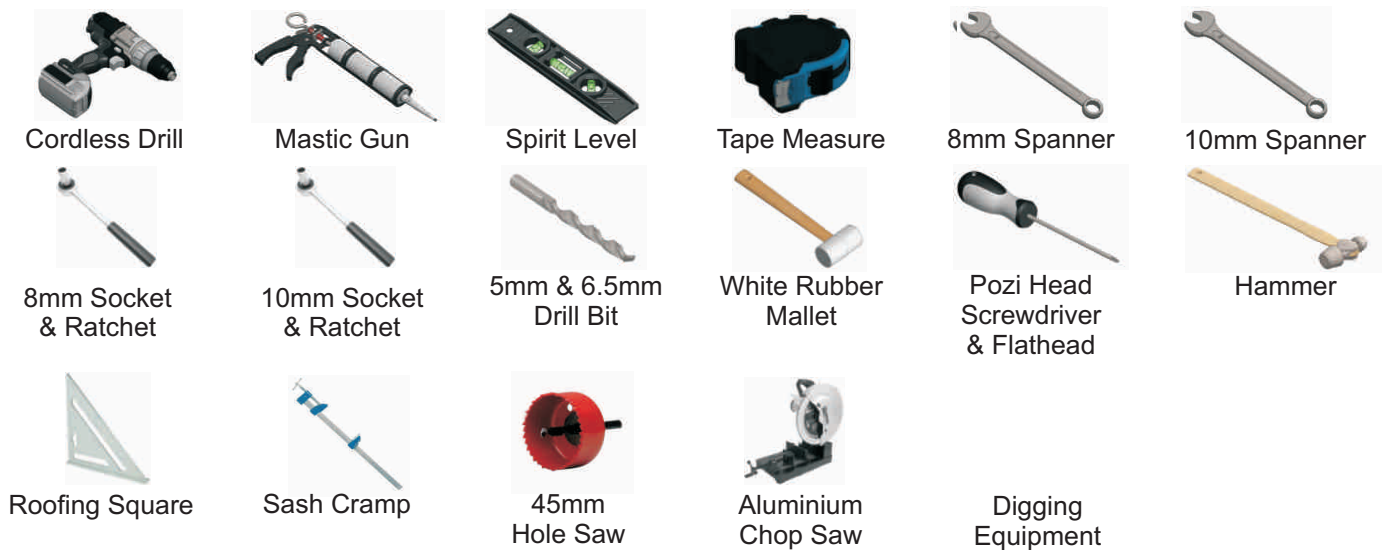

Parts Supplied

Below is a list of the parts supplied with your new Samson P16 Canopy. Please check that all parts are present before commencing the installation process.

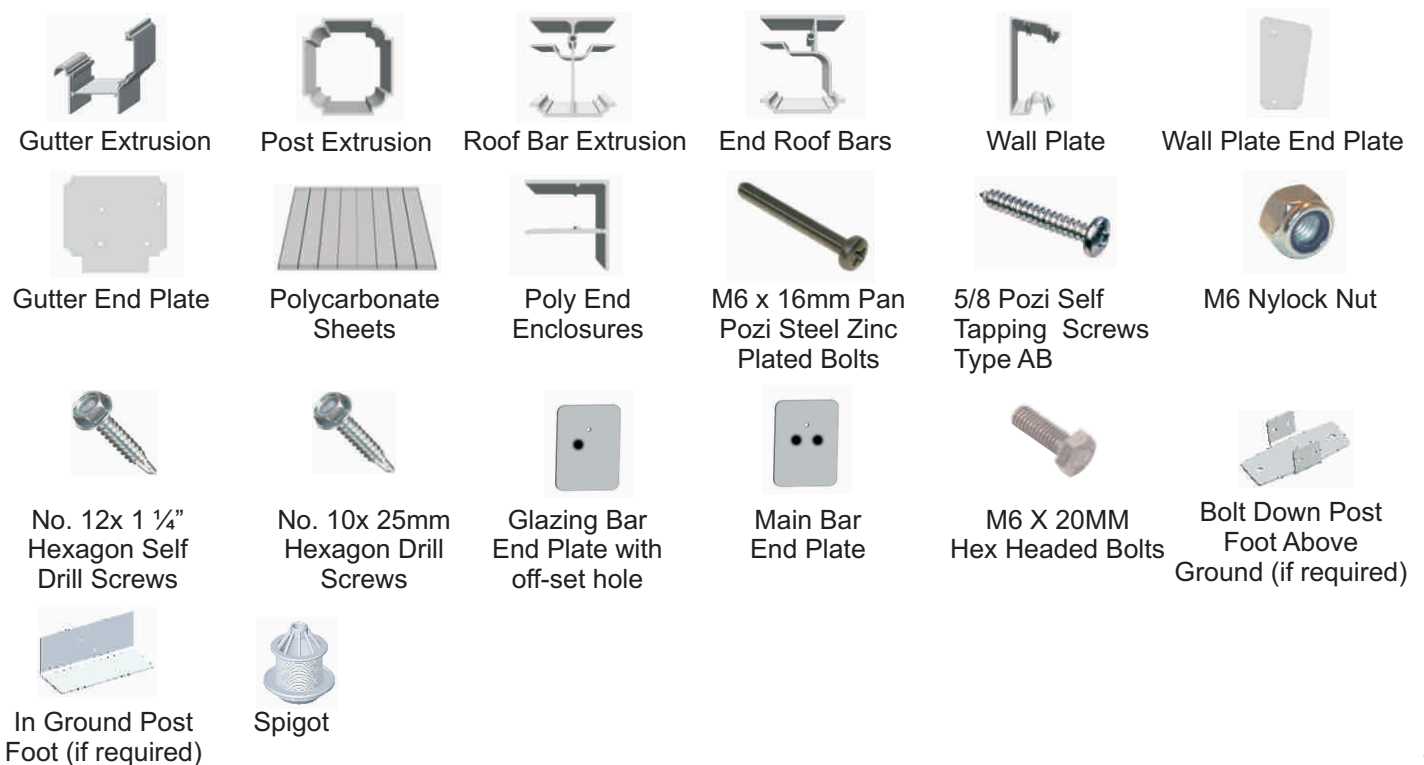

Preliminary Stages and Planning

Before starting your install please check all components for quantity and damage.

Below is a roof span chart which you MUST refer to in order to establish the maximum centre to centre dimensions of your roof bars and posts.

SPAN Chart Roof Bars	Up to 3.0m Projection	Up to & Including 3.5m Projection
System 16	1m Roof Bar Spacings	600mm Roof Bar Spacings

POST SPACINGS	Up to & Including 3.5m Projection
System 16	3m Post Spacings

PLEASE NOTE – A MAXIMUM OF 500MM OVERHANG ON THE GUTTER IS ALLOWED

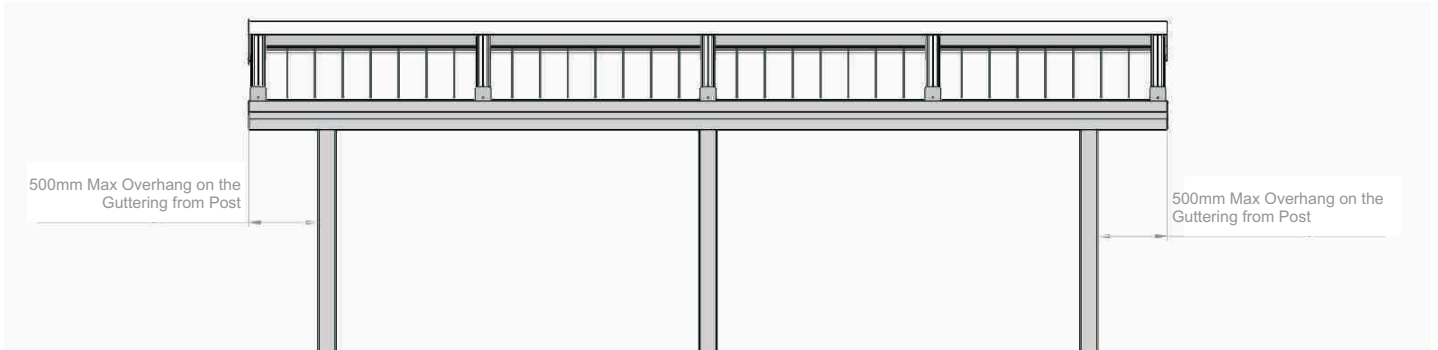

Before starting your installation please check all components for damage and ensure the parts are provided in the correct quantity.

You are now ready to start installing the structure, please turn the page and follow all steps within this guide.

STEP 1

Foundation Hole Positions for Posts

Establish the height of the canopy/carport at the back (wall edge) and the height of the canopy at the front. The height at the front must be above 2.1m to meet the minimum legal head height requirement.

Once you have established your height at the front and back, deduct the height at the front from the height at the back to give you "The Fall" (x). Measure distance 'x' up the wall and position your roof bar at this height on the wall. Let the other end touch the ground and where that touches will be the centre of your hole for the foundation.

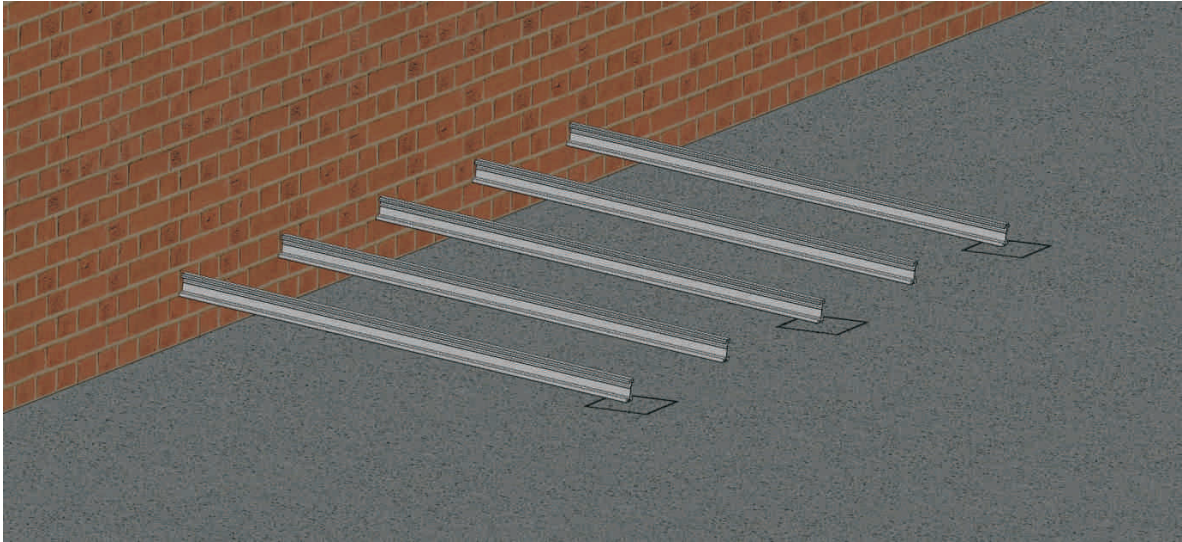

IMPORTANT: Use Roofing Square to ensure the bar used is held square to the wall.

STEP 2

Digging of Holes

Holes must be 300mm x 300mm x 600mm deep. This is only a guide. Please consult a structural engineer for verification

Ensure where the holes are dug that the base of the holes is level with each other.



STEP 3

Fitting of Wall Plate to the Wall

Measure 25mm in from one end of the Wall plate and approx 35mm down from the top of the inside profile and mark before you drill. Drill the wall plate using the correct sized drill bit for the suitable wall fixings that you intend to use (not supplied). Once this is done repeat at the other end. Continue to drill holes in the wall plate at approx 35mm down and at approx 300mm centres. This is only a guide. Please consult a structural engineer for verification. See diagram below.

You must ensure the wall plate is not twisted or bowed. Use a spirit level to make sure the wall plate is fitted level.

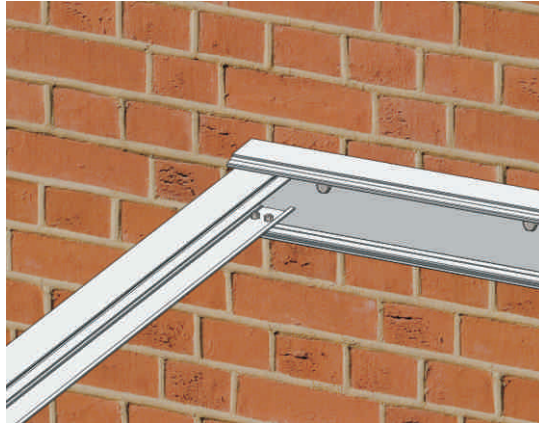

Using suitable wall fixings, fix the wall plate to the wall.

STEP 4

Fitting of Post Feet to Posts

Centralise the post foot to the post and attach using 2 x No. 12 x 1 ¼" self drill screws (**Note the post foot is only suitable for surface mounting the posts. If your posts need to be concreted into the ground please follow Step 4a**)

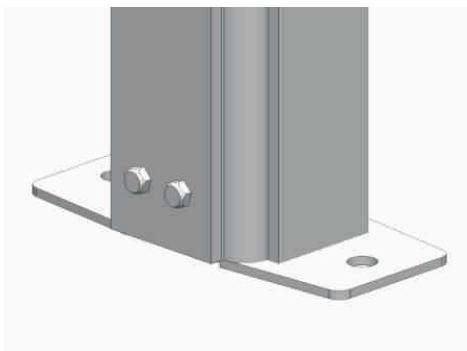

STEP 4a

Fitting of Post Feet to Posts

Centralise the post anchor to the post and attach using 2 x No12 x 1 ¼" self drill screws

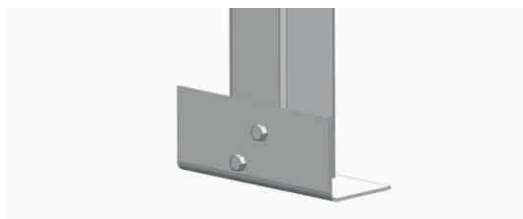

STEP 5

Cutting the Posts

Measure the height of the canopy/carport at the front and add to this dimension the depth of post that will be going into the ground. The total of this is the length at which your posts need to be cut.

STEP 6

Fitting of Post to Gutter Section

Position the gutter section over the posts and ensure they are in the correct position and are spaced in accordance with the span chart. Ensure the post is square to the gutter section using a Roofing Square. Using 2 x No12 x 1" 1/4 drill screws, secure through the front profile of the gutter into the post. Repeat on the inner side so that 4 screws in total are used to secure the post.

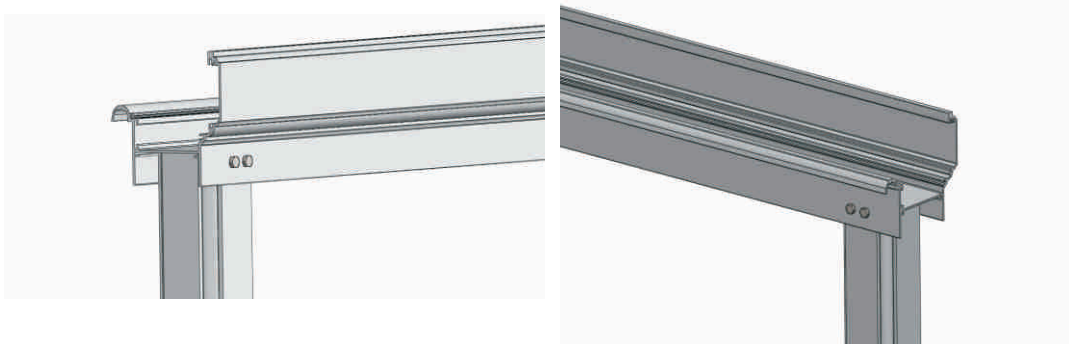

STEP 7

Stand Post & Gutter Beam Up

Using the excavated hole, position each of the post into the centre of the hole and lean the whole frame forward so that the back of the posts leans against the front of the hole; please see diagram overleaf.



If the posts are to be surface mounted, please secure the posts ensuring they are plum and square.

STEP 8

Fitting of the Glazing Bars

Pre drill the glazing bar that is going to fit into the gutter section. 15mm in from the edge and 30mm from the end of the bar drill your 6.5mm hole. Do this on both sides of the bar. This will allow the glazing bar to overhang the gutter section. See image below.

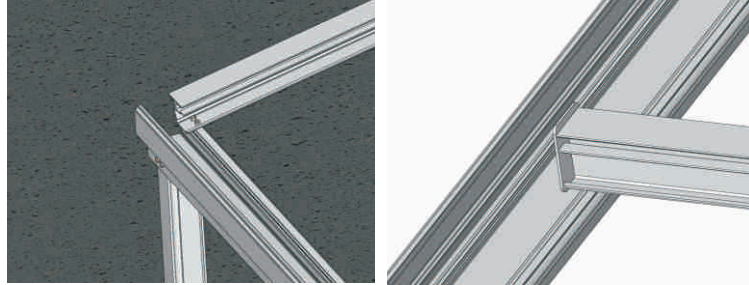

Starting with the End Glazing Bar, push this bar into the wall plate so that it is pushed back as far as possible and ensure the outside profile lines up with the edge of the wall plate. Rest the other end of the glazing bar on the radius inner section of the gutter section.

Using a 6.5mm drill bit, drill 1 No. hole through the bottom radius profile of the wall plate ensuring this also goes through the flat section of the glazing bar. Locate a 6mm x 16mm bolt through the hole and apply nut. Using an 8mm ratchet and screw driver tighten up.

Repeat this process on the other side of the glazing bar. Please see diagram below:



Make sure the glazing bar is in line with the gutter beam, then using the same fixing method as the wall plate secure the glazing bar to the gutter section. Your pre drilled holes will determine where you drill through on the radius of the gutter section. Please see diagram below:



Repeat the above with the last glazing bar at the other end of the wall plate and gutter beam to stabilise the wall plate and gutter beam while you seal the wall plate in the following section.

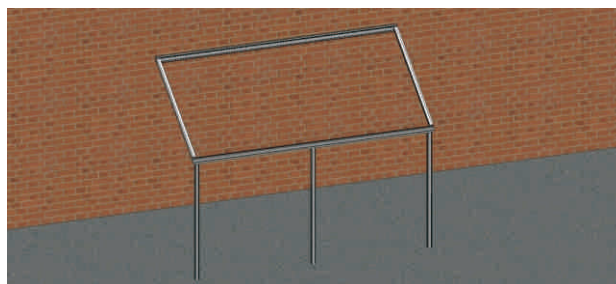

DO NOT FIT ANY MORE GLAZING BARS AT THIS STAGE

STEP 9

Sealing Wall Plate Against the Wall

If flashing or silicone is required to seal the wall plate against the wall it needs to be done prior to the polycarbonate sheets being fitted.

STEP 10

Polycarbonate Sheets

The polycarbonate sheet comes with a protective film fitted to both sides. This needs to be removed prior to fitting. The film with the writing on is the TOP face due to it's coextruded UV coating and therefore needs to be fitted facing the sunlight. The Polycarbonate sheet also has 1 foiled edge which must be fitted at the Gutter section end.

STEP 11

Fitting the Polycarbonate Sheet Capping

Cut the polysheet capping to the width of your polycarbonate sheet, minus 50mm to allow for the sheet fitting into the glazing bar so that the capping is only fitted on the exposed edge. This capping is fitted into the Wall Plate end first and attach using Soudel Crystal Clear Bonding Silicone agent. See product reference. Apply a bead of this silicone along the top and bottom of the inside face of the capping

And additionally, down the edge of the capping as a precaution for water ingress.

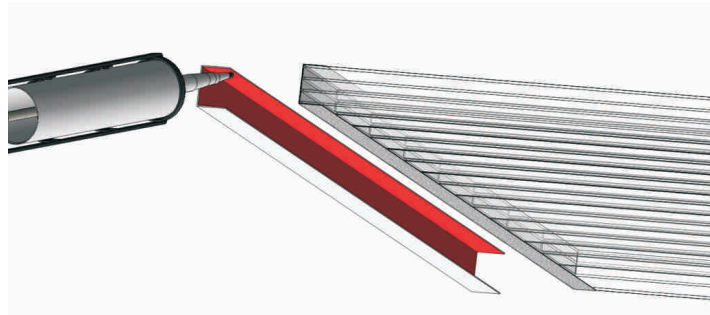

The capping can then be knocked onto the sheet using a white rubber mallet.

STEP 12

Glazing the Canopy/Carport

If your Canopy/Carport is fitted against a wall at one end you must start the glazing process from the wall end and work progressively across to the open end.

Run a bead of silicone along the entire length of the glazing bar. This needs to be applied on the inside of the top profile prior to pushing the polycarbonate sheet into place. If any silicone leaks out onto the sheet wipe off with a cloth.

Push the polycarbonate sheet that has the polysheet capping on the end firmly into the wall plate and into the channel of the end glazing bar. Make sure this is firmly in place. This should leave the polycarbonate 10mm shorter than glazing bar at the gutter end, refer to the CAD drawing to ensure the correct spacing's are present.

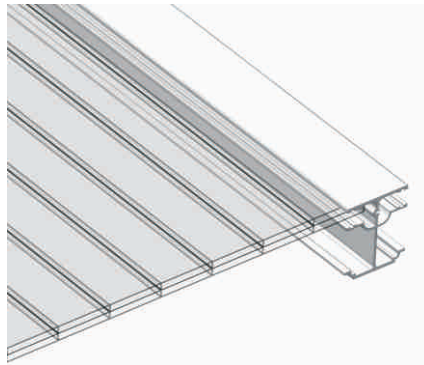

Place your next glazing bar into the polycarbonate sheet and push firmly into the channel. Please see diagram below. Fix the glazing bar onto the wall plate and gutter section, as previously described in step 8 make sure all glazing bars have a bead of sealer down both edges of the glazing bar to prevent water ingress as described above.



STEP 13

Fitting of Polysheet End Closure on the Front of the Sheets

The end closure needs to fit the width of the polycarbonate sheet between the 2 glazing bars. See Image below. Apply a bead of this silicone along the top and bottom of the inside face of the capping

And additionally, down the edge of the capping as a precaution for water ingress and make sure the breather tape is sealed on the edge of the sheet to prevent water ingress.

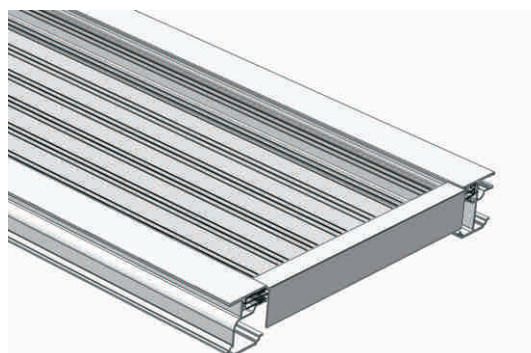

STEP 14

Fitting of Bar end Plates

Please note that the End Bar has a different End Plate to the Main Bars. The End Bar plate has a hole that is off set (not on the centre of the plate). These are fitted using a No. 10 x 25 mm Hexagon Headed Screw that is supplied. See Image below.

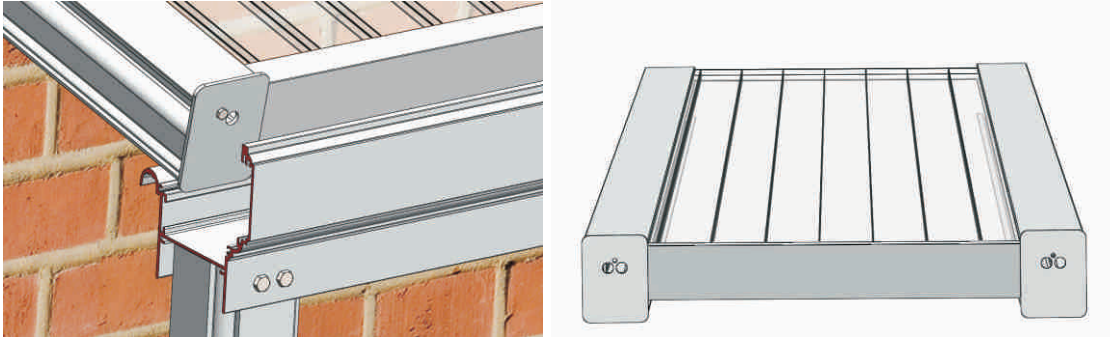

STEP 15

Fitting of Gutter End Caps

Ensure the gutter is completely dry, then apply a continuous bead of Sudaflex around the end of the gutter extrusion, then line up the 4 holes on the gutter end plate with the port holes on the end of the gutter section and using 4 No. x 5/8" self tapping screws secure in place. Finally using a dobbing stick or finger with disposable gloves apply a bead around the internal gutter section at the end. Repeat at the other end. Please see diagram below:

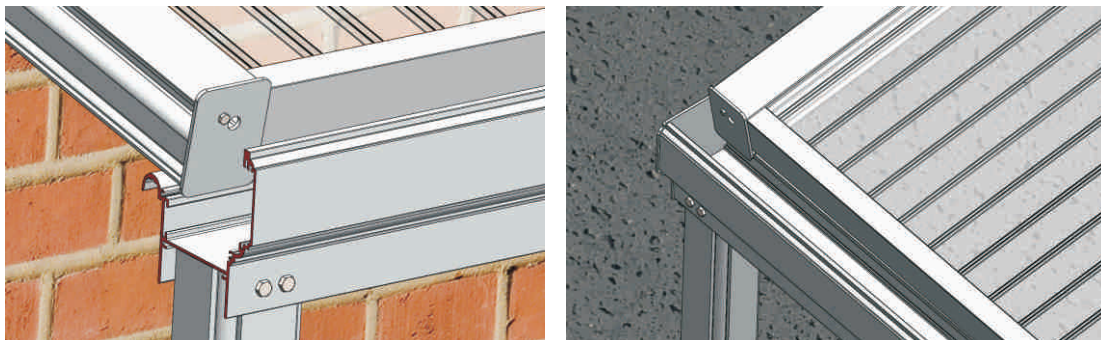

STEP 16

Fitting of Wall Plate End Caps

Line up the 2 No. holes on the wall plate end plate with the port holes on the end of the wall plate section and using 2 x 5/8" self tapping screws secure in place. Repeat at the other end. Please see diagram overleaf.



STEP 17

Make Sure your Canopy/Carport is Square

To ensure the carport is square, using the roofing square, attach one edge of the square to the wall plate and the other edge will need to continuously touch the other edge of the square. This will ensure the gutter beam is perpendicular to the wall plate.

STEP 17a

Ensuring your Canopy/Carport is Level

Using a spirit level ensure the front beam is completely level and your posts are plumb.

STEP 18

Concrete around the Posts

Using the correct aggregate apply to the excavated holes and make good.

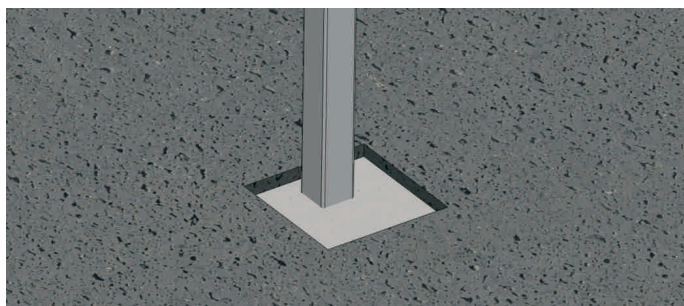

STEP 19a

Victorian Upgrade Drainage System

If you are not installing the Victorian Upgrade, please skip this step and move onto step 19b

Drill a hole no more than 40mm diameter in the gutter section where your post is to be located. Push the post in to the gutter section below the hole. Please see diagram overleaf.

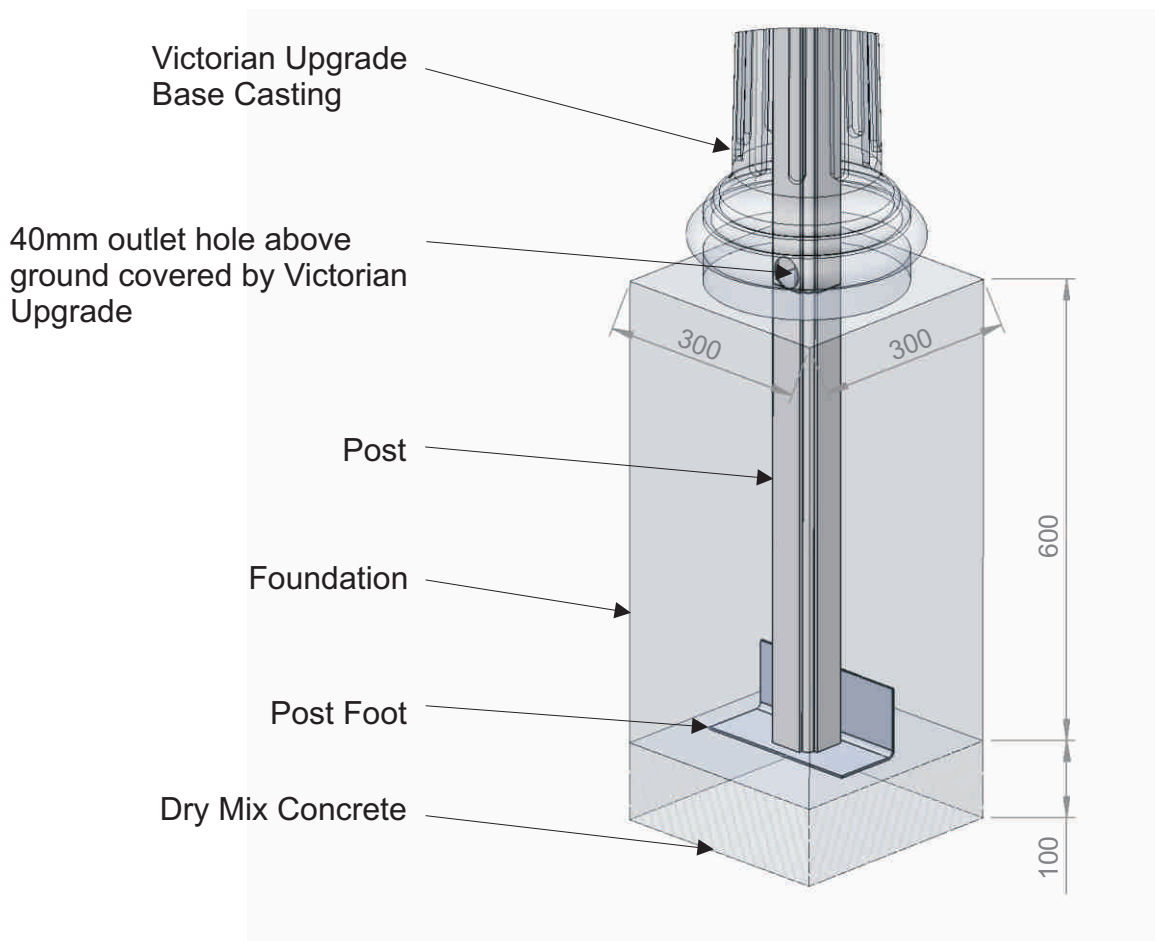

Note:

1. You must ensure the bottom of the hole has at least 100mm of dry mix concrete under the post to prevent subsidence of the post, and that is compacted hard.
2. Ensure as you fill the 300 x 300 x 600 foundation, that you fill the centre of the post level to the bottom of the 40mm hole to prevent rainwater going into the bottom of the post.
3. We recommend that when installing above ground outlets, you perform this procedure on every post to minimise puddles.

Disclaimer: We cannot be held liable for puddles of excess rainwater around the column base.

STEP 19b

Standard Drainage System

Drill a hole 45mm diameter using a hole saw in the gutter section where your downpipe is to be located, Insert the outlet into the hole and tighten. Push the downpipe in to the gutter section below the hole over the outlet. Using the downpipe clips provided secure to one of the posts or the wall depending on the position of your outlet.

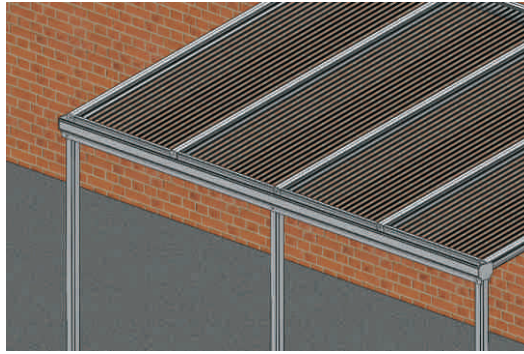

STEP 20

Capping off the Fixings

Using the supplied caps, ensure the fixings have been capped off and the structure has been cleaned.

STEP 21

Applying the Stickers

When applying the logo ensure to fix one at each end.

If your canopy or carport is longer than 6m, you may need to join the gutter sections as follows:

Joining Gutter Sections

You will need the following to join every gutter beam:

- 3No. flat aluminium joining plates: 1No. 300mm x 24.5mm, 1No. 300mm x 70mm, 1No. 300mm x 47mm x 8mm thick
- 1No tube of Sudaflex marine grade sealer
- 1No roll of masking tape
- 8No. M6 x 20mm hex headed bolts
- 8No. M6 self locking nuts
- 1No. 6.5mm drill bit
- 1No mastic gun
- 1No drill with 8mm self driller attachment
- Industrial wipes
- uPVC cleaner
- Roll of industrial tissue paper

1. Make sure you only use **Sudaflex**; normal silicon sealer will not do.
2. Now apply a liberal amount of Sudaflex to both sides of the eaves beam on the internal vertical sections and the underside of the gutter where the plate fits into this will enable you to bond the four joining plates.



3. Flatten any excess Sudaflex with the spatula and apply a generous amount of sealer around every edge of both plates. Then insert all plates half way in to one half of the join.
4. Apply ample amounts of Sudaflex across all corresponding areas of the opposite eaves beam
5. You are now ready to marry the two eaves beams together but you must ensure they are flat and level to each other.

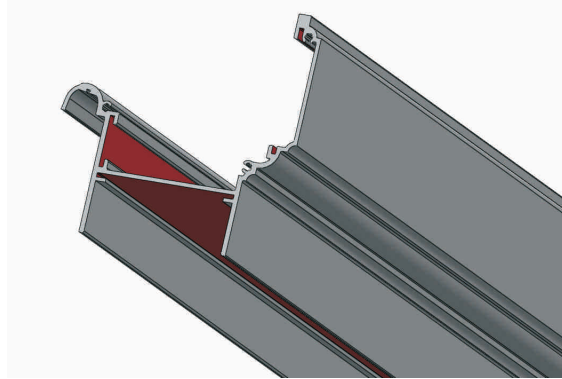

6. Once you have married the two beams together you must leave at least a **3mm gap between the two but no greater than 5mm**

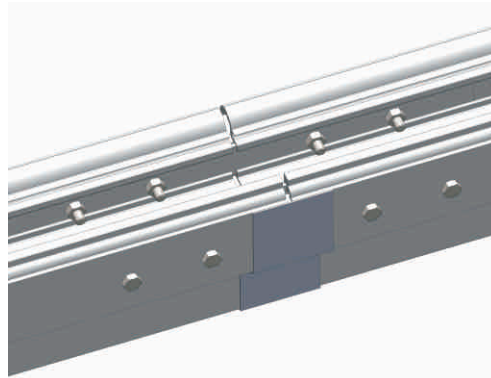

- 6a. Drill 2 No. x 6.5mm holes through the gutter channel and joining plates at 50mm and 100mm either side of the join line at the front and back of the Gutter Channel. Using the 6mm Hex Headed Bolts and Nuts supplied bolt through the gutter channel and joining plates and tighten up. See image above.
7. After around 15 to 20 minutes, stand the Eaves Beam with legs attached up, and attach the bars as described in the above procedure.
8. Once your canopy is glazed, your legs are plumb and your eaves beam is level up and down, left and right, and front to back, ensure your gutter is dry and the surface temperature is at least 4 degrees. If you are installing in the winter, you may need to use a heat gun.
9. Then you will need to apply the final amount of Sudaflex into the bottom of the Eaves Beam, please see diagrams below:

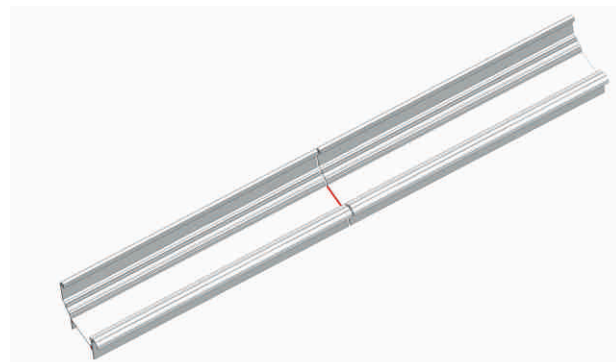
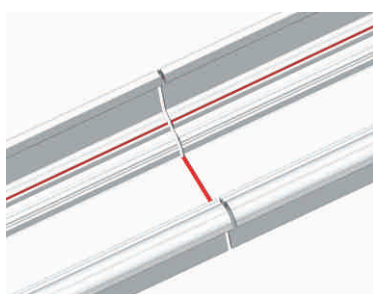

10. Apply a generous amount around the edges of the flat plates inside the gutter and ensure all gaps are filled with Sudaflex internally.
11. Fit the external gutter cover plates.

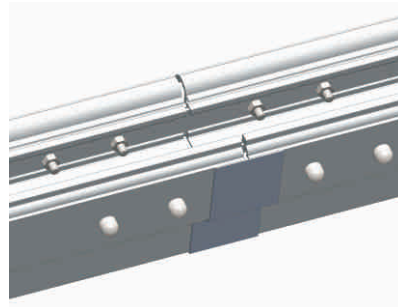
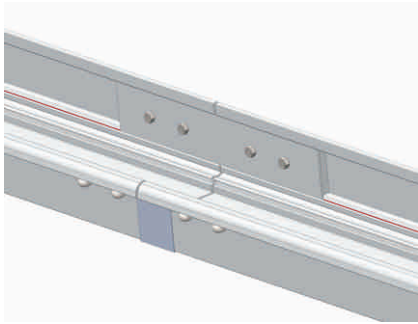

12. Fit the cover plate centrally over the gutter join line, these plates are fixed using Sikaflex.
13. Fit the nut covers and colour code if required.

STEP 22

Fitting the Gallows Brackets

Using the support channel, provided, fix this channel underneath the gutter section using 2 x No12 x 1 ¼". You only need to fix this on the outside face of the gutter channel. With this channel in place you can now fix the Gallows Bracket in place.

Using 2 x No12 x 1 ¼" drill screws fix the Gallows brackets directly into the post and then into the support channel you have previously fitted. See photo below. Using caps provided cap off all screw heads.

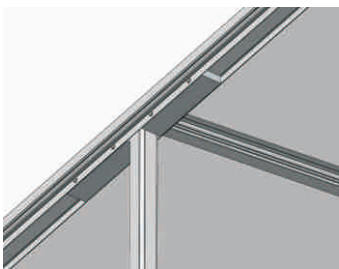
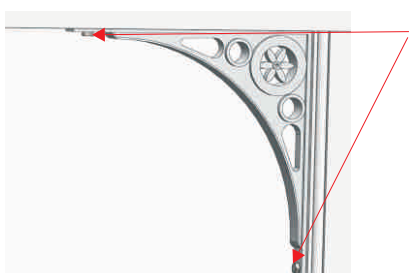

Image shows gutter channel fitted.



Image shows gallows brackets fitted to gutter channel and post.



Please see the position of the fixings.



MILWOOD
GROUP

Canopy, Carport and Veranda Systems

0800 525 442

www.thegaragedoorcentre.co.uk

