

// New Decograin® surface finishes Golden Oak and Rosewood



Series 2000 Garage Doors

Superior Design, Engineering Excellence





The original Hörmann up-and-over garage door

The ultimate in quality and aesthetics

Every Hörmann up-and-over door produced is the result of more than 50 years experience in the building of garage doors. Quality and safety, aesthetics and convenience, and of course engineering excellence, is why Hörmann is Europe's No. 1 manufacturer of up-and-over garage doors. And the wide variety of styles means you're sure to find the perfect door to complement your home. Everything speaks in favour of the original!

Contents



Hörmann (Series 2000) garage doors are assembled at the new Hörmann factory in Leicestershire from components sourced from both the continent and the U.K.

All Hörmann garage doors are manufactured according to the Quality Management System DIN ISO 9001 and meet all the requirements of the European Standard 13241-1.



The classic designs in steel	4
The steel designs	6
The natural beauty of timber	8
The timber designs	10
Elegant and durable GRP doors	12
The GRP designs	14
Design your own door	15
Let your garage see the light of day	16
Beautiful handles add value to your door	17
Automatic doors with electric operator	18
The Safety Check	20
Safety features	22
Fitting details	26
Overview of other domestic doors	30

Some of the doors shown in this brochure have special features and therefore do not always represent a standard supplied version.

Colours and surfaces are shown as accurate as printing techniques allow.

Copyright. No part of this brochure may be reproduced without our prior approval. We reserve the right to make changes.



Certified brand quality with long-term guarantee

It goes without saying that Hörmann doors and operators are precisely matched and for your safety are tested by the TÜV (German Technical Inspectorate) and for compliance with the relevant standards.

* Terms and conditions of the guarantee, specifications and all further details on Hörmann up-and-over doors can be found on our website at www.hoermann.com

Design 2104, Marquess, in crisp-looking standard Traffic white



The classic designs in steel

Stylish designs - outstanding performance

Series 2000 steel doors are timeless in appearance and always up-to-date. Whether choosing one of the ribbed designs that offer a quiet elegance to blend in with almost any environment, or one of the panelled designs that give a lasting prestige of classical beauty.

Irrespective of the colour, all steel doors are primed with a high-grade powder-coating. The galvanized door leaves are protected against corrosion and the adverse effects of the environment right into the cut edges.



Design 2001, Vertical



Design 2304, Georgian with windows



Design 2103, Caxton // NEW



Marquess Decograin® "Golden Oak" // NEW

Bring colour into play!

Steel garage doors can be supplied in a variety of colours from the RAL colour chart:



Dark brown RAL 8028 Light blue RAL 5005 Steel blue RAL 5011



Green RAL 6005 Red RAL 3003 Black RAL 9005

Garage side doors can only be supplied to colour match in the following colours: RAL 8028, RAL 3003, RAL 5011 and RAL 6005



Decograin® "Golden Oak"



Decograin® "Rosewood"

The Decograin® surface finishes with the authentic appearance of real timber.

A selected range of door designs is available in the Decograin® surface finishes "Golden Oak" and "Rosewood". With its embossed structure, this new UV-resistant synthetic foil coating on the outer face of the door leaf displays all the authentic features of real timber. Thanks to the special surface protection, the door retains its good looks for much longer.

The steel designs



2001 Vertical ▲



2002 Horizontal ▲



2003 Chevron ▲



2004 Georgian ▲



2103 Caxton // NEW ▲



2101 Ilkley ▲



2104 Marquess ▲



2304 Georgian with windows ▲
* For glazing options refer to page 16



2404 Kingston ▲



2504 Countess ▲

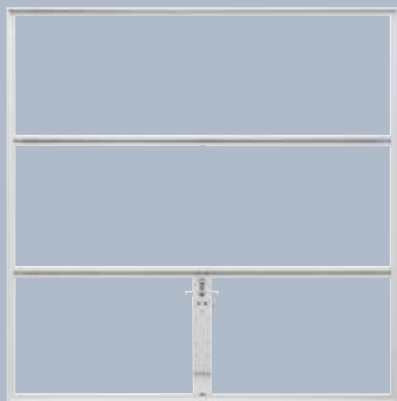

2011 Open-for-infill (White) ▲

Design your own door with the open-for-infill frame

The Hörmann open-for-infill leaf frame is perfectly prepared to accept a timber infill of your own design or a GRP door leaf of other make.

The minimum infill weight is 6 kg per m² and the max. infill weight is 10 kg per m². Please see page 15 for more details.

Note:

White OFI is only available in certain sizes. Please enquire.



Vertical Decograin® // NEW ●



Horizontal Decograin® // NEW ●



Georgian Decograin® // NEW ●



Marquess Decograin® // NEW ●

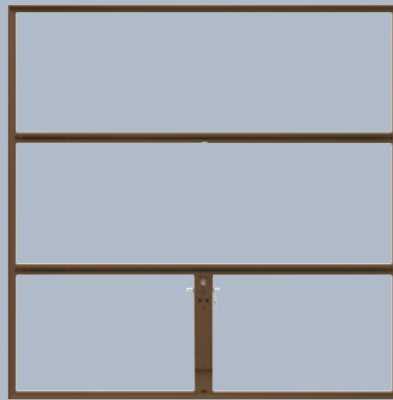

2011 Open-for-infill (Brown)

Matching steel side doors



2001 Vertical



2004 Georgian

Whether your garage is attached to the house or separate, you might be looking for a side door that perfectly matches your garage door. In addition to the side doors shown we offer matching side doors for designs 2002, 2003, 2304, 2104, Vertical Decograin®, Georgian Decograin®, Marquess Decograin® and 2011.

- Available in "Golden Oak" and "Rosewood"

- ▲ Designs are available in:
 Dark brown RAL 8028
 Light blue RAL 5005
 Steel blue RAL 5011
 Green RAL 6005
 Red RAL 3003
 Black RAL 9005

* Please note that the Georgian and Marquess designs are limited in size range in colours." (Please Enquire For Details)



The natural beauty of timber

Timber infills exquisitely crafted for a lasting appeal

Whatever the style of your property, traditional or modern architecture, our styles of timber doors in either panelled or tongued and grooved design, offer you the choice to find a style that will add warmth and character to your home. The main material used for these doors is carefully selected cedarwood, with its finely figured grain and variation in colour.

Attention to detail and high quality joinery are the hallmarks of Hörmann Series 2000 timber doors. Each hand-crafted panel is secured into our open-for-infill leaf frame.



Design 2020, Gatcombe



Design 2009, Vertical double door



Design 2010, Chevron



Design 2119, Leicester // NEW



Fully finished colour options
 Wood needs protecting. That's why in addition to the factory impregnation it is important to apply a pigmented wood preservative to a timber garage door in order to protect it against atmospheric influences and the effects of UV rays. You can thus blend in the door with the timber elements of your property. At Hörmann we offer 9 colour options as fully finished factory coat.

The timber designs



2005 Measham // NEW



2007 Jacobean



2008 Tudor



2014 Rutland



2009 Vertical or Horizontal



2010 Chevron



2013 Caxton



2019 Garage Light
For glazing options refer to page 16



2020 Gatcombe



2019 Mallory // NEW
(Horizontal or Vertical)

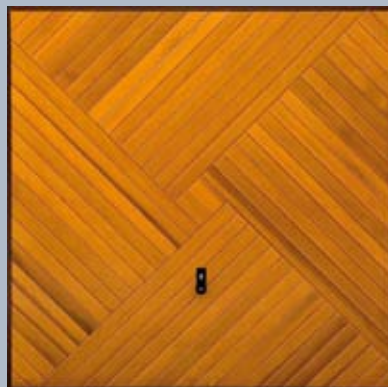

2010 Burbage // NEW



2014 Shepshed // NEW



2119 Leicester // NEW



2121 Chesterfield // NEW



2122 Middleton // NEW



2023 Coachman // NEW

Matching timber side doors



2019
Garage Light
For glazing
options refer
to page 16



2008 Tudor



2020 Gatcombe

With wood being a natural product the finish of the doors supplied may vary from those shown. Some movement of components and joints may occur, particularly in changes of weather from very wet to hot sunshine.

All our timber doors are supplied with a dip immersion coat of Sikkens WP560 Colour re 006 Light Oak; this coating is for temporary protection only. A fully finished option is available, see colours on page 9.

A matching side door might be exactly what you are looking for to complete the aesthetic appearance of your house! In addition to the side doors shown we offer matching doors for designs: 2005, 2007, 2014, 2009, 2109, 2013, 2114, 2119, 2010 and 2121.



Elegant and durable GRP doors

Highly popular, easy to maintain

If low maintenance is an important factor to you a Glass Reinforced Polyester door is just what you're looking for. While requiring minimum maintenance it will give you the long-lasting elegant look and character of genuine timber.

Glass Reinforced Polyester, often referred to as fibreglass, is a tough and durable material. The door leaves are secured within our dark brown open-for-infill frame ensuring long-term stability.



Design 2035 Hartfield



Design 2047, Bourton // NEW



Design 2034 Peshurst



Design 2049 Moreton // NEW

We have a range of colour options for GRP doors and you'll surely find a design and colour that complements all your architectural requirements. For glazing options please refer to page 16.



White
Supersmooth

Mahogany
Woodgrain

Dark Oak
Woodgrain

Countryside Oak
Woodgrain

Cherry Oak
Woodgrain

White
Supersmooth

Bourton
Burford

Bourton
Burford

Bourton
Burford

Bourton
Moreton

Peshurst
Hartfield

Coniston
Stamford

Moreton
Woodstock

Moreton
Woodstock

Moreton
Woodstock

Moreton
Woodstock

Livingston
Windermere

Peshurst
Hartfield

Peshurst
Hartfield

Peshurst
Hartfield

Livingston
Windermere

Livingston
Windermere

Livingston
Windermere

Livingston
Windermere

The GRP designs

There are many beautiful styles to choose from in the Hörmann GRP range of garage doors. Offering the choice from rustic designs to modern panels that give the feel and impression of natural timber. For colour options please refer to page 13.



2034 Penshurst ▲



2035 Hartfield ▲



2040 Livingston ▲

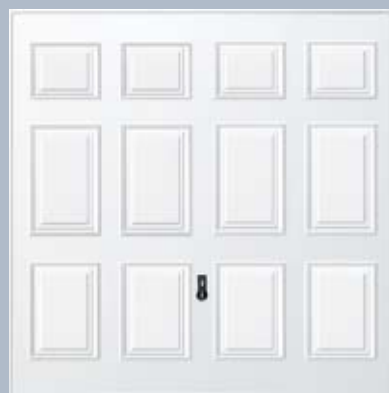

2041 Coniston ● ■



2044 Stamford ● ■



2042 Windermere ▲ ■



2047 Bourton // NEW ▲



2048 Burford // NEW ▲



2049 Moreton // NEW ▲



2050 Woodstock // NEW ▲

- Supersmooth white surface finish
- ▲ Woodgrain surface finish
- Window options available, please refer to page 16.

Design Your Own Door

Design 2011, Open-for-infill

Hands on and watch your own ideas take shape

Applying the timber boarding couldn't be easier. Because Hörmann supplies the frame and struts predrilled at 30 mm spacings. Give free rein to your creative talent: regardless of whether the timber boarding is arranged vertically, horizontally or according to your own design. You can proudly show off your own creation.



It's fun to be hands on and be creative.



This is the solid basis



- **Extremely sturdy frame construction with fully welded reinforced struts**
- **Fully galvanized, door leaf frame additionally with high-grade polyester primer coating (Dark brown RAL 8028 or White RAL 9016).**
- **Frame and struts predrilled at 30 mm spacings.**
- **Illustrated fitting instructions with suggested designs**



It goes without saying that the 2011 design is also available for double garages. While creating your infill please respect the following infill weights for your own safety and security:
Single garage door size, depending on exact door size, infill weight between 6 and 10 kg/sqm.
Double garage door size, max. infill weight 7 kg/ sqm.

Advice on site treatment

Once fitted, it is essential that you treat your door with a commercially available pigmented wood preservative to protect it against UV rays as well as fungal and insect attack.

Long lasting and durable

Of course you can also apply a GRP door leaf to our 2011 open-for-infill frame.

This door construction offers you two cladding options:

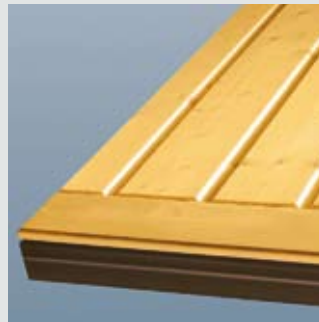

Infill overlapping the frame, whereby the frame and bottom section are entirely concealed.

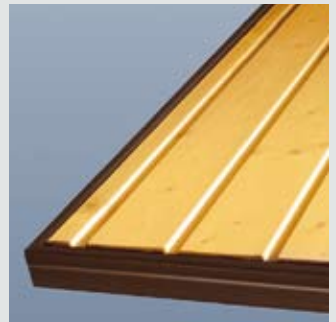

Timber infill within the frame.

The glazing options



Let your garage see the light of day !

Glazing is more than just a design feature, it also saves you having to build an additional window in your garage.

Taking advantage of daylight means you can also use your garage as a workshop.

Steel door glazings



Plain



Diamond



Crossed

The Georgian design (2304) is available with windows as an optional extra for a range of sizes showing on the size-chart on page 7. All windows come with crystal panes. For Decograin® doors the window frames are painted to match the colour of the door leaf.

Timber door glazings



Plain



Diamond



Crossed

For timber design 2019 Garage Light we offer a plain, diamond and square design glazing. The simulated 'leaded light' designs can be combined with a clear or stippled opaque pane. Panes are made of tough, durable perspex.

GRP door glazings



Plain



Diamond



Crossed

For designs 2041 Coniston and 2042 Windermere we offer a plain, diamond and square design glazing. The simulated 'leaded light' designs can be combined either with a translucent or smoked pane. Design 2044 Stamford is available with a translucent, smoked or black pane. All panes are made of tough, durable perspex.



Stamford

The handle options



Synthetic black, standard



Cast aluminium, white



Cast aluminium, silver finish



Cast aluminium, brass finish



Polished stainless steel



Brushed stainless steel



Cast aluminium, rustic style



Cast aluminium, bronze finish

The flush-fitting cylinder lock can also be mastered with other locks in your home.



Beautiful handles add value to your door

The garage door handle developed by designers and security experts is unique in its shape.

Thanks to the ergonomic styling you always have a secure, comfortable grip.

The track-guided automatic up-and-over garage doors just keep running and running ...



Hörmann automatic up-and-over doors

because they offer greater convenience and security

You can operate a Hörmann automatic door as conveniently as your TV set. On the press of a button, you drive into your garage, protected from all weathers. When it's dark, the direct route affords you greater safety and security. It goes without saying that Hörmann doors and operators are tested by the TÜV (German Technical Inspectorate) as a single safety unit.

Choose between two innovative Hörmann operators

ProMatic // NEW



The inexpensive starter model as an introduction to the Hörmann premium quality, for a maximum of 10 door cycles (open/close) per day. Opening speed: 14 cm/s.

ProMatic

For doors up to 5000 mm wide.
(max. 10 m² door surface)
Peak force: 650 N

ProMatic P

For doors up to 5500 mm wide.
Peak force: 750 N

ProMatic Akku

For garages not connected to the mains supply and doors up to 3000 mm wide.
Peak force: 400 N

SupraMatic



The high-quality operator with an array of additional functions for a max. of 50 door cycles (open/close) per day. Opening speed: 22 cm/s.

- Halogen lighting can be switched on/off separately
- Door with additional opening height for a well ventilated garage

SupraMatic E

For doors up to 5500 mm wide.
Peak force: 800 N

SupraMatic P

For doors up to 5500 mm wide, heavy timber doors and garage doors with wicket doors.
Peak force: 1000 N

The Operator Technology

- 868.3 MHz radio frequency with a stable range
- Every operator comes with a 4-button hand transmitter and a micro 2-button hand transmitter
- Integral receiver // NEW
- Automatic door latching affords effective protection against forced opening.
- On encountering an obstruction, a reliable automatic cut-out stops the door immediately
- "A soft" start and "soft" stop saves wear and tear on both the door and operator
- Maintenance-free patented toothed belt
- Internal emergency release
- Easy to install. Everything is precisely prepared.

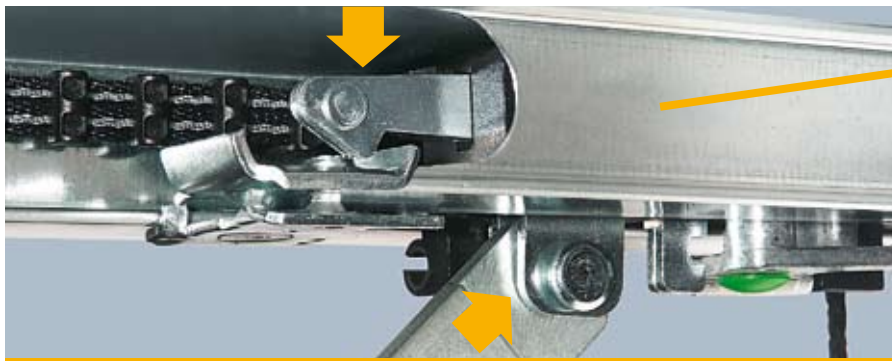

Door latching in the operator boom – a Hörmann patent

...with automatic door latching

The operator system latches the door

The door automatically latches on closing, making it impossible to lever it open. This unique automatic latching system is a mechanical device, so remains fully functional even in the event of a power failure.



Increased safety for you and your family!

The retractable gear



1 Finger-trap protection



2 Ceiling track



3 Spring system



4 Track roller well



The safety checklist for your old retractable up-and-over door

Do flexible plastic strips on the frame and door leaf prevent trapped fingers?

1 Yes No

Is it guaranteed that even if a spring should break, an imbalance no greater than 200 N is produced?

3 Yes No

Is there a safety distance of 25 mm between the lifting arm and the frame?

1 Yes No

Are the springs safeguarded to prevent them from being catapulted into the air?

3 Yes No

Does the bearing bracket have protective caps to prevent injury if inadvertently reached into?

1 Yes No

Is the spring system designed in such a way that there is no risk of trapped fingers?

3 Yes No

Is the door safely and securely guided as well as protected against uncontrolled movements?

2 Yes No

After opening, does the door come to a safe stop?

4 Yes No

Are the tracks designed in such a way that it is impossible for the rollers to derail?

2 Yes No

On power-operated up-and-over doors: are the maximum closing forces to EN 13241-1 complied with?

Yes No

Is the door leaf safeguarded against crashing to the floor?

3 Yes No

Even if you have answered only one of the above with "no", your door is no longer safe.

How Safe is Your Up-and-Over Garage Door?

The canopy gear

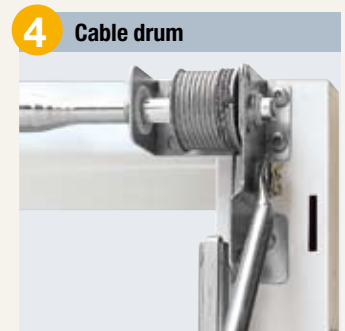
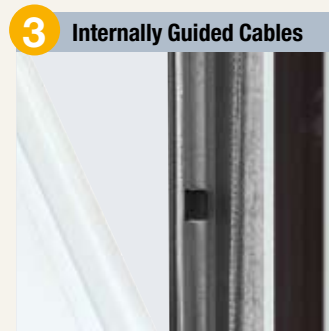
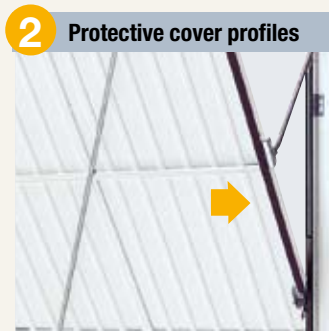
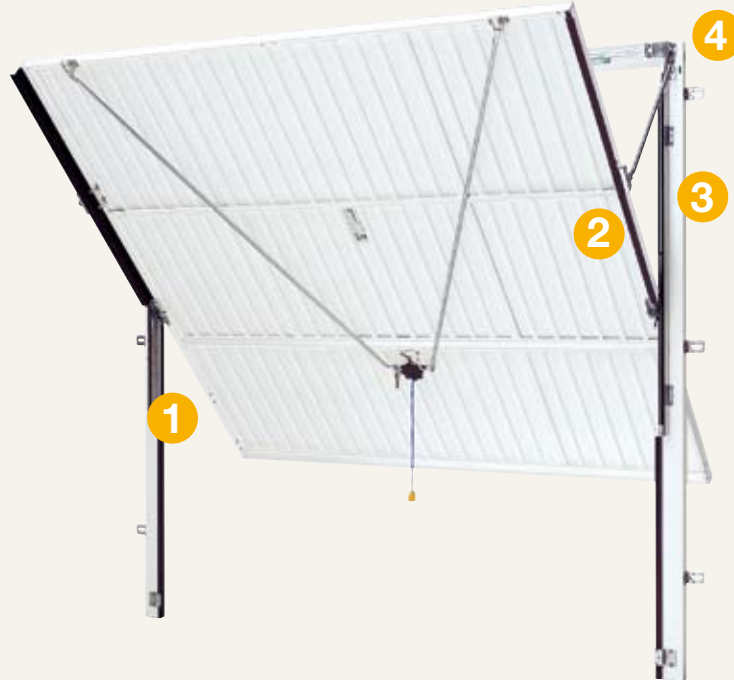

The safety checklist for your old canopy up-and-over garage door

Is there an anti-fall safeguard fitted to your present door to prevent injury if a cable breaks? **1** Yes No

Is the door safely and securely guided as well as protected against uncontrolled movements? **1** Yes No

Are the tracks designed in such a way that it is impossible for the rollers to derail? **1** Yes No

After opening, does the door come to a safe stop? **1** Yes No

Do protective cover strips on the frame and the door leaf prevent trapped fingers? **2** Yes No

Are the door's cables internally guided? **3** Yes No

Does your door have a cable drum with deep grooves to ensure the cable fits securely and prevents cables jumping? **4** Yes No

Even if you have answered only one of the above with "no", your door is no longer safe.

Retractable gear for single and double garages

State of the art technology to the latest European Standard 13241-1



Assured quality

All Hörmann retractable geared doors are tested and certified according to the high safety requirements and performance characteristics of the European Standard 13241-1.

This gives you the reassurance that your purchase of a Hörmann up-and-over door is a safe investment.

It's worthwhile making a comparison.



Safety and Security

- 1 Multiple spring safety system** In the event that one of the springs should break, the others safeguard the door. A broken spring cannot fly off into the air. The springs are always optimally dimensioned depending on the door size and weight:
Single door type: 3 - 4 springs per side
Double door type: 6 - 10 springs per side
- 2 Precision track guidance** prevents the door leaf from "derailing".
- 3 Unique track well**
Once fully opened, the door is gently cushioned and always brought to a safe, reliable halt in the track well.
- 4 Protective caps over the lifting arms**
Flexible plastic caps protect the entire joint area, so there's no risk of trapped fingers.
- 5 Protective profiles on door leaf and frame**
Flexible plastic profiles down the sides act as reliable side trap guards between the door leaf and frame. Double garages have a flexible seal at the bottom to provide foot trap protection.
- 6 Safety distance between springs**
The distance between the spring windings is so small that even children's fingers are reliably protected.

A smooth, quiet door action

Everything is perfectly matched: the 4-point suspension, the precision track guidance, the smooth-running plastic rollers, the plastic profiles down the sides (no steel on steel contact) and the adjustable spring assemblies.

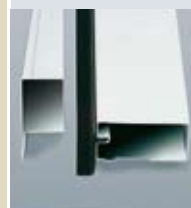

Sturdy steel frame

Galvanized mild steel, welded into a wide robust box section construction gives the optional door frame great

strength and stability. The finish is powder-coated.



Security locking

Factory-fitted profile cylinder locking is a standard feature. Two keys are provided for outside locking. Inside

locking is by a snib positioned on the lock body. An internal "star" handle is also supplied. Master key locking is an optional feature.

Easy fitting saves time

Hörmann offers a steel fixing frame for all retractable doors. This frame makes an on-site timber frame redundant and saves valuable installation time as it is quick and easy to fit.



Single Door



Double Door



The benefits also apply to doors fitted to a timber frame

The horizontal door leaf reinforcements lend the Hörmann up-and-over door a high degree of stability.

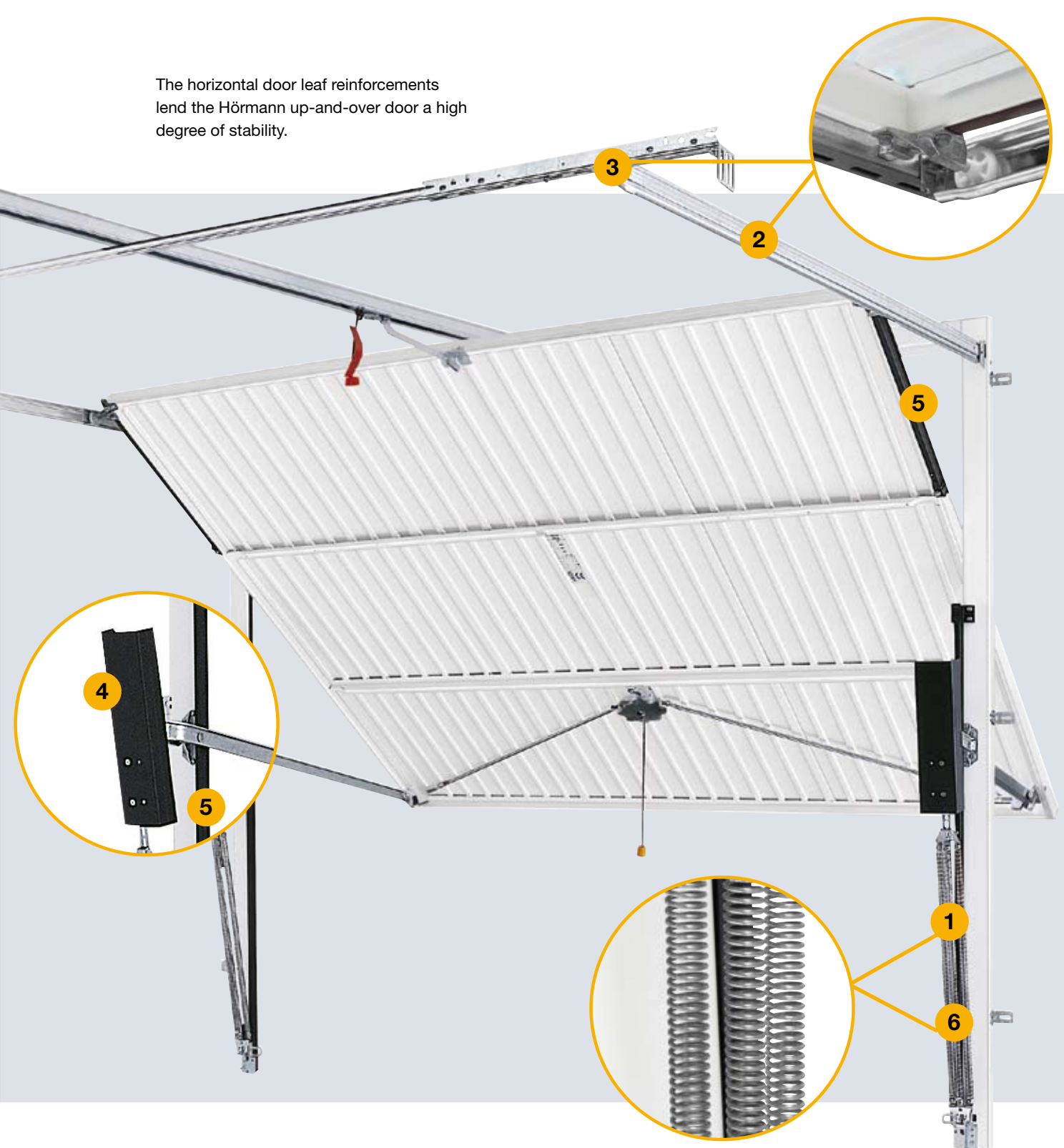

Burglar resistant latching
With the new latching system, the corners of the door leaf are firmly fixed to the frame, making it impossible to lever the door open. An easy-to-install retrofit kit allows you to equip your garage door with top latching in addition.



4-point locking
If even more security is required a 4-point locking arrangement is available as a factory-fitted optional extra.



Retractable Plus
Still conforming to the EN 13241-1 this gear allows for a clear drive through passage wider than the standard retractable gear.

Canopy gear for single doors

Modern and safe design meeting all the requirements of the European Standard 13241-1

Assured quality

Hörmann canopy geared doors are tested and certified according to the high safety requirements and performance characteristics of the European Standard 13241-1. This gives you the reassurance that your purchase of a Hörmann up-and-over door is a safe investment. It's worthwhile making a comparison.

Safety and Security

- 1 Anti-fall safeguard**
The side tracks feature punch-outs at 100 mm spacings. In the event of a cable or spring breaking, the bolt can fully engage in the hole, thereby safely arresting the door. To provide trap protection, the holes are covered over with plastic tape which is perforated by the bolt as soon as the safeguard comes into play.
- 2 Protective cover profiles on door edges**
Flexible profile strips on the closing edges of the door leaf prevent fingers from getting trapped.
- 3 Internally guided cables**
The cables are guided inside the guide rails to protect from injuries.
- 4 Safe stop**
A specially designed spring buffer stop makes sure the door comes to a safe halt in the open position.
- 5 Cable drum**
The cable drum is diecast alloy and has deep grooves to securely retain the 2.4 mm cable.

A smooth, quiet door action

Everything is perfectly matched: the precision vertical track guidance, the smooth-running plastic rollers, the plastic profiles down the sides (no steel on steel contact) and the galvanized torsion spring.



Sturdy steel frame

Galvanized mild steel, welded into a wide robust box section construction gives the optional door frame great strength and stability. The finish is powder-coated.



Security locking

Factory-fitted profile cylinder locking is a standard feature. Two keys are provided for outside locking. Inside locking

is by a snib positioned on the lock body. An internal "star" handle is also supplied. Master key locking is an optional feature.

Easy fitting saves time

Hörmann offers a steel fixing frame for all canopy doors. This frame makes an on-site timber frame redundant and saves valuable installation time as it is quick and easy to fit.



Single Door



The benefits also apply to doors fitted to a timber frame

If it is important to you to operate your door electrically, we would recommend the retractable gear as this is the technically finest solution.



2-point latching

Hard PVC-latches in tough zinc diecast housings engage automatically and quietly at either side into steel latch keeps.



4-point locking

If even more security is required a 4-point locking arrangement is available as a factory-fitted optional extra.

Fitting details for

Series 2000 retractable gear

Position of anchors

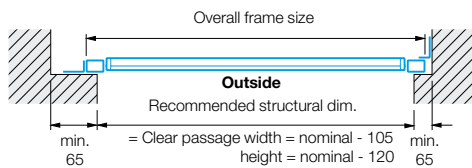
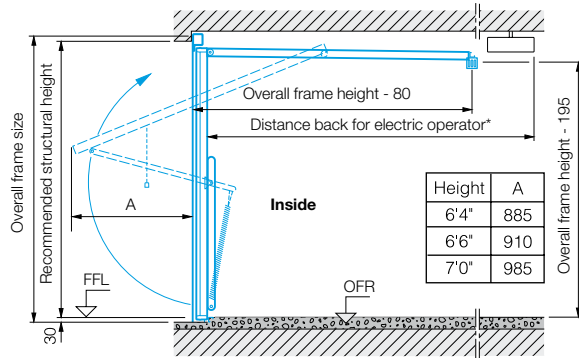
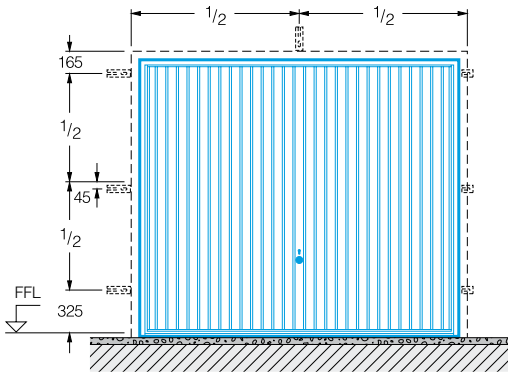

* Distance back for ProMatic/SupraMatic electric operator:
3200 mm up to door height 2500 mm
3450 mm up to door height 2750 mm

Fitting behind the opening

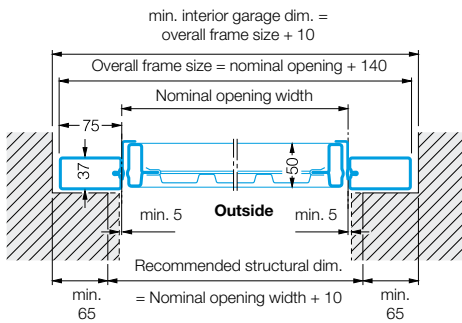

The recommended structural dimensions are recommended planning dimensions. Minimum sideroom, headroom and opening sizes are all based on these dimensions.

Door with flat floor

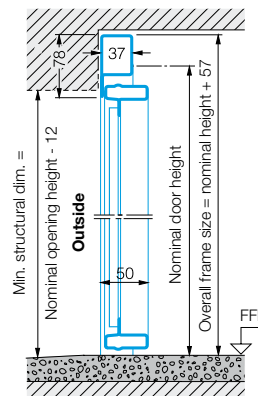

With ProMatic/SupraMatic operator

No additional headroom required.
Exception: some timber designs allow 15 mm clearance.

Fitting in the opening

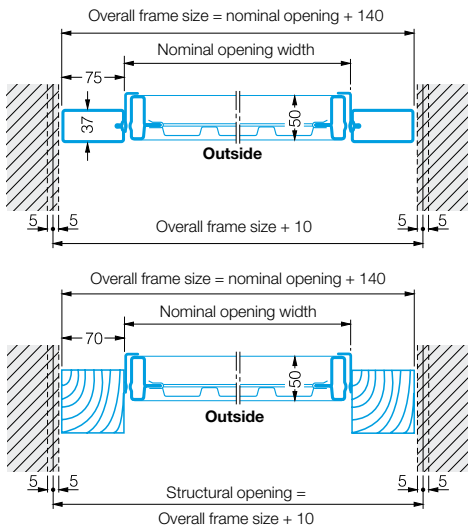

Fitting in the opening requires that the given dimensions be adhered to with greater accuracy.

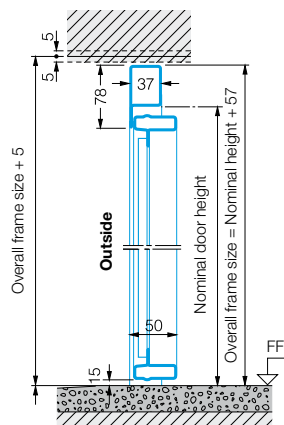

With ProMatic/SupraMatic operator

No additional headroom required.
Exception: some timber designs allow 15 mm clearance.

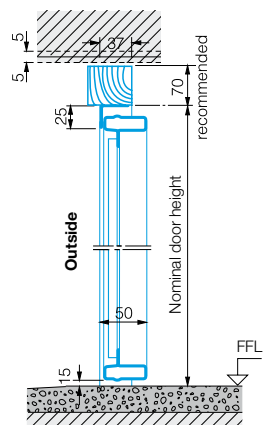

Fitting details for

Series 2000 canopy gear



Position of anchors

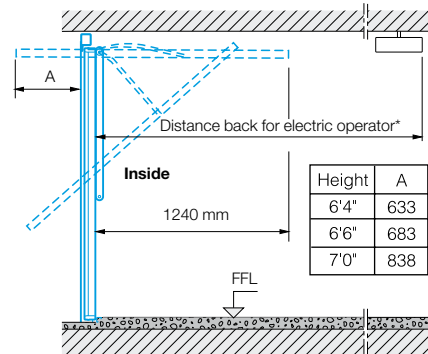
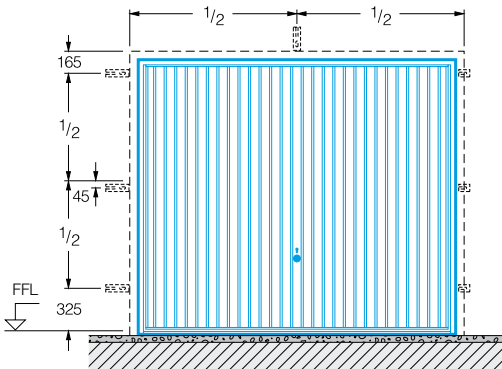

Clear passage:

Width: nominal opening less 40 mm (1 1/2") only within bottom 1/3 due to flexible seals.

Height:

nominal door height - 140

For doors with operator 40 mm headroom above top crossframe required. (Overall frame size + 40 mm)

Fitting behind the opening

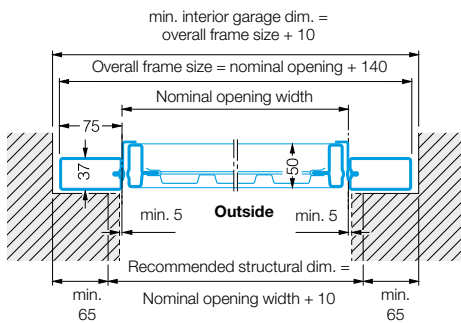

Behind opening installation with the Hörmann steel frame allows for a wider range of structural openings to be spanned, this can be particularly helpful with non-standard openings which would normally require special sized doors. The diagrams show the minimum tolerances that should be adhered to. PLEASE NOTE: the overall frame sizes are shown as additions to the nominal opening sizes.

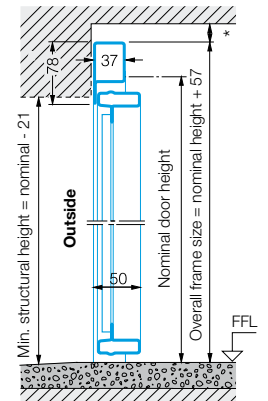

* 40 mm headroom required for operator

Fitting in the opening

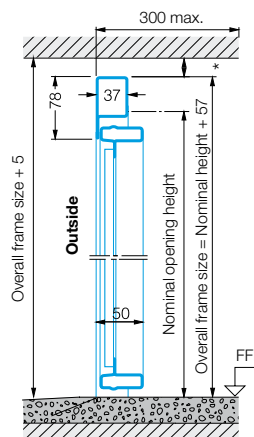
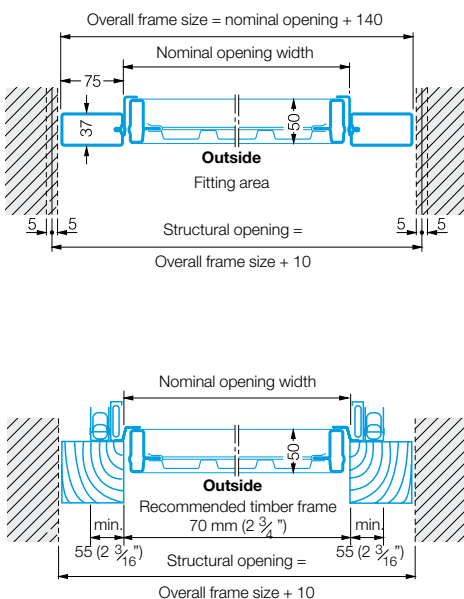

* 40 mm headroom required for electric operator

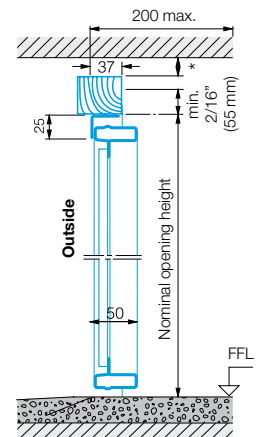

The size chart gives the structural opening sizes for each door size, this frame is the standard 2 3/4" (70 mm) square. A narrow application gear is provided for doors to be fixed to timber frames allowing the frame to be a minimum of 2 3/16" (55 mm) square if required, allowing the door to be fitted to smaller structural opening. For electric operation with canopy door a bow arm must be purchased separately.

For overall dimensions of Hörmann steel frame, add 5 1/2" (140 mm) to nominal opening width and 2 1/4" (57 mm) to nominal opening height.

Fitting details for

door type series 2000 retractable gear for double doors

Position of anchors

Dimensions in mm

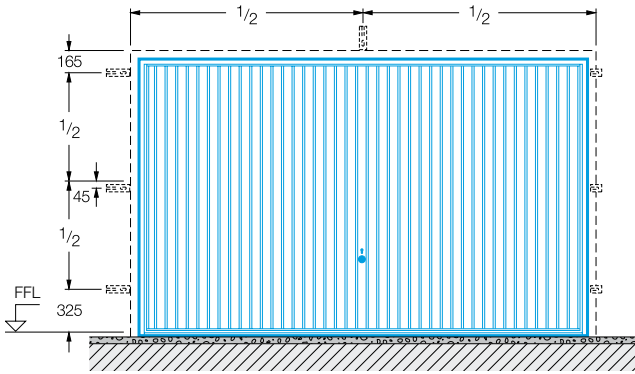

Overall frame size

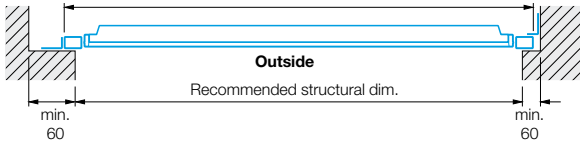

Recommended structural dim.

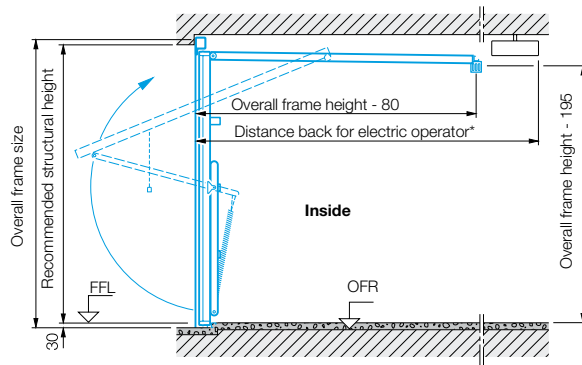

* Distance back for electric operators:

- 3200 mm up to door height 2500 mm ProMatic/SupraMatic
- 3450 mm up to door height 2750 mm ProMatic/SupraMatic

Fitting behind the opening

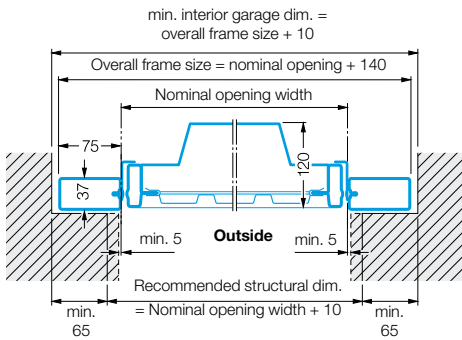

The recommended structural dimensions are recommended planning dimensions. Minimum sideroom, headroom and opening sizes are all based on these dimensions.

Door with flat floor

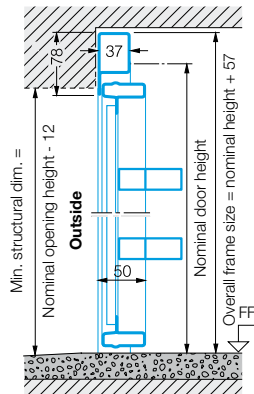

With ProMatic/SupraMatic operator

No additional headroom required.
Exception: some timber designs allow 15 mm clearance.

Fitting in the opening

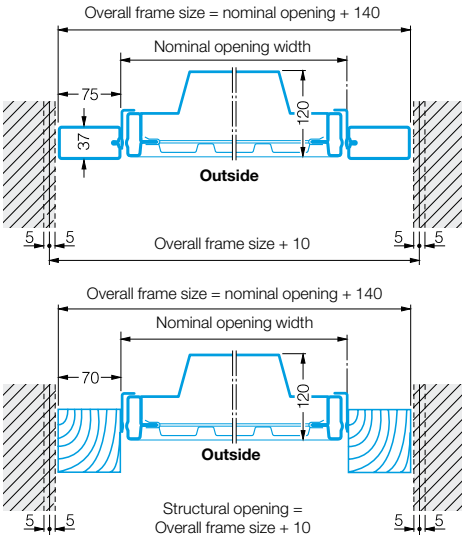

Fitting in the opening requires that the given dimensions be adhered to with greater accuracy.

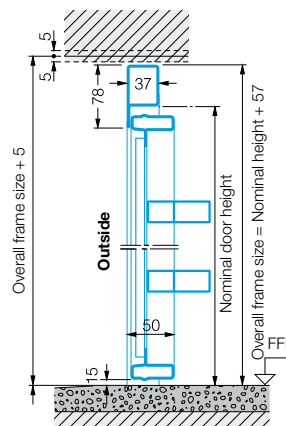

With ProMatic/SupraMatic operator

No additional headroom required.
Exception: some timber designs allow 15 mm clearance.

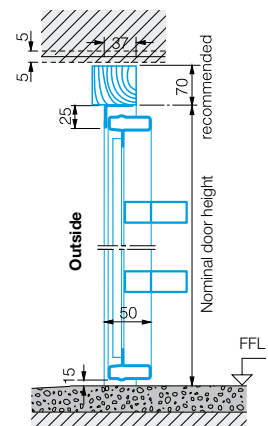

Fitting details for garage side doors



Single-leaf

Position of anchors

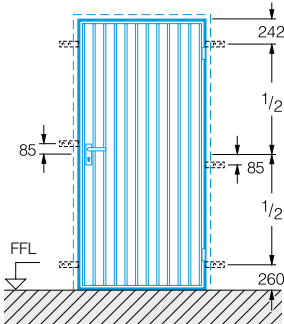

Door with flat floor

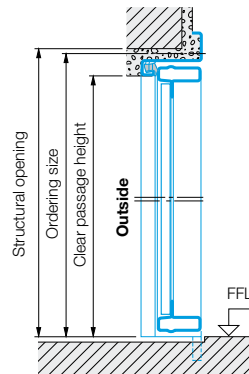

Door with stepped floor

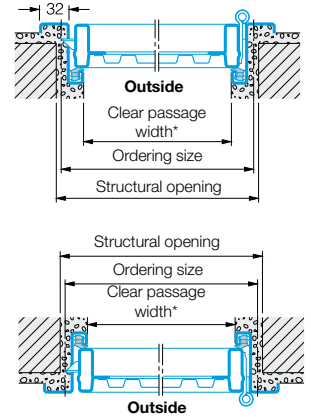
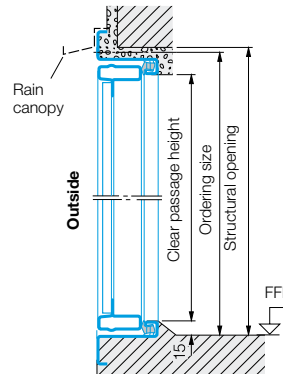

Standard sizes for single-leaf doors				Dimensions in mm			
Ordering size (BR)		Structural opening		Clear passage dimensions			Height of lever handle from FFL
Width	Height	Width	Height	Width	with threshold Height	without threshold Height	
875	1875	885	1880	830	1840	1855	990
875	2000	885	2005	830	1965	1980	1050
875	2125	885	2130	830	2090	2105	1110
1000	2000	1010	2005	955	1965	1980	1050
1000	2125	1010	2130	955	2090	2105	1110

For doors with a stepped floor, opening outwards, the ordering height is always measured from the finished floor line of the deeper floor.

Standard sizes with steel infill and for site infill are supplied as standard for internal fitting (opening inwards). By reversing the fittings, the doors can be converted to external fitting (opening outwards). Designs with timber infill overlapping the frame only possible for external fitting.

* With an opening angle of less than 170°, the clear passage width is reduced.

Block frame for fitting into the opening: dimensions and versions on request.

Special sizes and special versions on request. Maximum size range (BR): 1250 x 2375 mm.

Double-leaf

Position of anchors

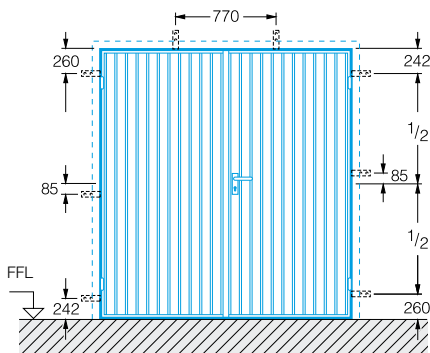

Door with flat floor

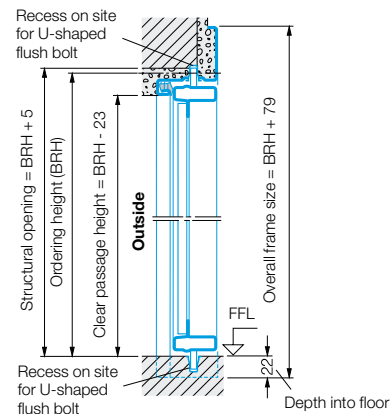

Door with stepped floor

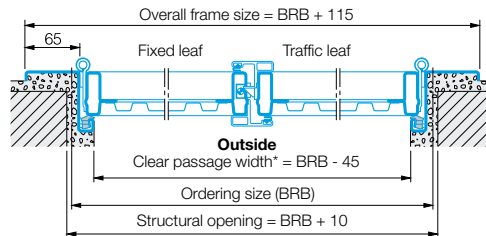
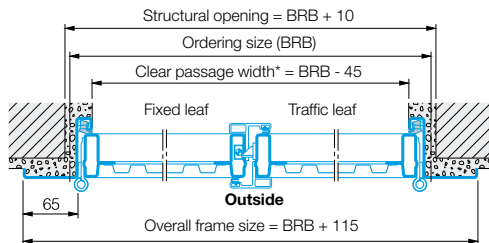
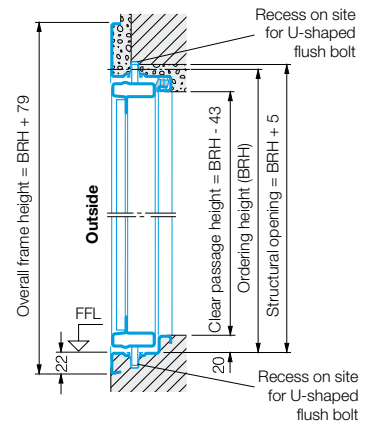

* With an opening angle of less than 170°, the clear passage width is reduced.

Block frame for fitting into the opening: dimensions and versions on request.

Supplied as standard for external fitting (opening outwards), traffic leaf on right. If internal fitting (opening inwards) or traffic leaf on left required, state on order.

Single-leaf

RH hinged LH hinged

Double-leaf

Traffic leaf LH hinged Traffic leaf RH hinged

Internal fitting

For internally fitted doors, the threshold angle/transport angle should always be removed. Adequate water drainage to the outside must then be ensured. For doors on the weather side external fitting is preferable.

Single-leaf

RH hinged LH hinged

Double-leaf

Traffic leaf LH hinged Traffic leaf RH hinged

External fitting

With threshold profile.

Size range for double-leaf doors

Width (ordering size): from 1300 to 2500 mm
 Height (ordering size): from 1750 to 2250 mm
 Panelled designs only up to BRB = 2000 mm

Hörmann Sectional Doors

Convenience Combined with Reassuring Safety and Security



Decograin® Golden Oak

With its unique embossed graining, the UV-resistant synthetic foil coating on the outside of the steel sections conveys the authentic character of timber. The special surface protection preserves the appearance of the door long-term.

Silkgrain® surface finish

This silky-smooth elegant surface finish is particularly easy to clean. Approx. 25 % of the outer material is reinforced to ensure that even wider doors have adequate stability over the entire surface.

Woodgrain-embossed surface finish

On this robust woodgrain structured surface with authentic sawn timber look, minor scratches can be repaired without leaving any visible sign of damage.



Ask for our sectional door brochure



Hörmann Sentinel Door MZ-1

A quality door for multiple applications



Possible applications

- private use as well as use in trade and industry
- outside door for store
- construction containers
- basement
- side doors for gate openings
- escape doors with anti-panic feature

Product features

- Rain canopy to protect from water ingress
- Reliable locks for improved security
- Two security bolts for anti-theft
- Door leaf 45 mm thick, made of 0.9 mm steel, rebate on two sides, powder-coated surface finish for long-lasting protection
- Spring hinge for automatic closing and adjustable hinge for easy fitting on site
- EPDM seal on 3 sides for improved thermal and sound insulation

Available in a range of colours custom-made to RAL colour chart



Ask for our
Sentinel door
brochure



Hörmann: Quality without Compromise



Hörmann KG Amshausen



Hörmann KG Antriebstechnik



Hörmann KG Brandis



Hörmann KG Brockhagen



Hörmann KG Dissen



Hörmann KG Eckelhausen



Hörmann KG Freisen



Hörmann KG Ichtshausen



Hörmann KG Werne



Hörmann Genk NV, Belgium



Hörmann Beijing, China



Hörmann Gadco LLC, Vonore TN, USA

Hörmann is the only manufacturer worldwide that offers you a complete range of all major Door, Window and Loading Bay products from one source. We manufacture in highly-specialized factories using the latest production technologies. The close-meshed network of sales and service companies throughout Europe, and activities in the USA and China, make Hörmann your strong partner for first-class building products, offering "Quality without Compromise".

GARAGE DOORS

OPERATORS

INDUSTRIAL DOORS

LOADING EQUIPMENT

HINGED DOORS

DOOR FRAMES

Hörmann (UK) Ltd, Gee Road, Coalville, Leicestershire LE67 4JW
Phone (01530) 513000, Fax (01530) 513001

